

**Montageanleitung
BH 200/205 / TYP 220
Eckkabine,
2 Drehtüren an Fixteilen,
mit Winkel-/
Profilbefestigung**

**Assembly instruction
BH 200/205 / TYPE 220
corner cubicle,
2 swing doors fixed to
in-line panels, fixed with
brackets/profiles**

Wichtige Informationen:
Important information:

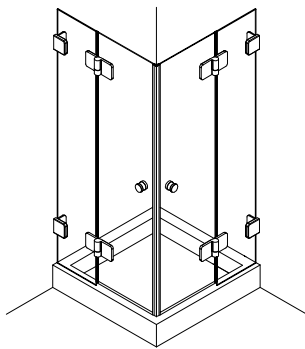

mit Winkelbefestigung
fixed with brackets

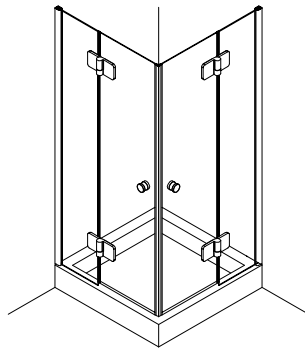

mit Profilbefestigung
fixed with a profile

① = Bauteil/Baugruppe
Components

1. ; 1.1 ; ... = Montagefolge
Installation sequence

Vor der Montage Glasflächen
mit handelsüblichem Glasreiniger
im Bereich der Klemmflächen reinigen.

All glass clamping areas are to
be cleaned with standard glass
cleaning products prior to installation.



keine Verdünnung verwenden
Do not use thinners

Wichtiger Hinweis

Glas beim Auspacken immer mit Schutz (Pappe oder Ähnlichem) auf den Fußboden stellen.
Kanten und Ecken des Glases nicht anstoßen lassen.
Konstruktionsbedingt ist bei rahmenlosen Duschtrennungen keine absolute Abdichtung erreichbar.
Die Montage der jeweils beiliegenden Dichtlippen gewährleistet die maximal erreichbare Dichtigkeit.
Alle Maßangaben in mm!

Important notice!

While unpacking the glass always use the protection of the wood or cardboard, as available and set it on the floor. Be careful not to bump into anything with the trim and edges of the glass.
Because of the construction of the frameless shower enclosure a complete seal cannot be obtained.
The installation of the enclosed seals, provide the maximal obtainable sealant.
All measurements are in mm.

Montagewerkzeug:
Mounting tool:

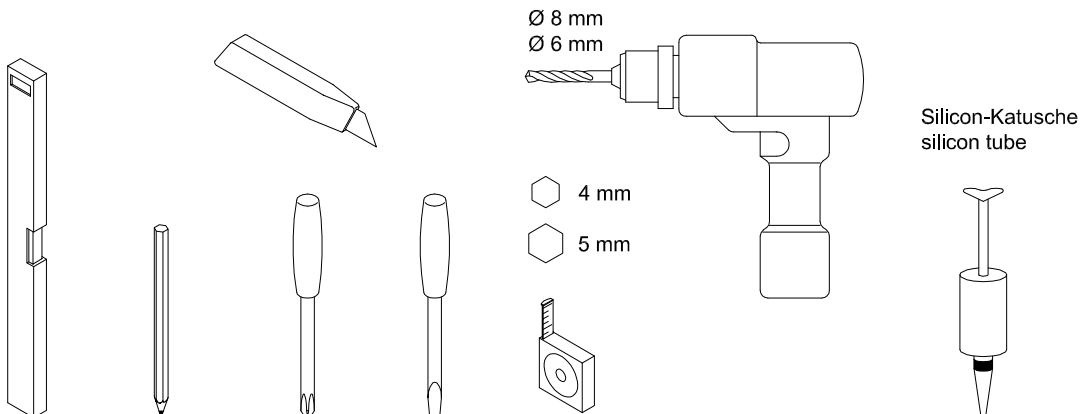

Lieferumfang:
Scope of delivery:

BH 200
mit Gegenplatte
with counter plate



BH 205
mit Versenk
with countersenk



mit Profilbefestigung:
fixed with a profile:

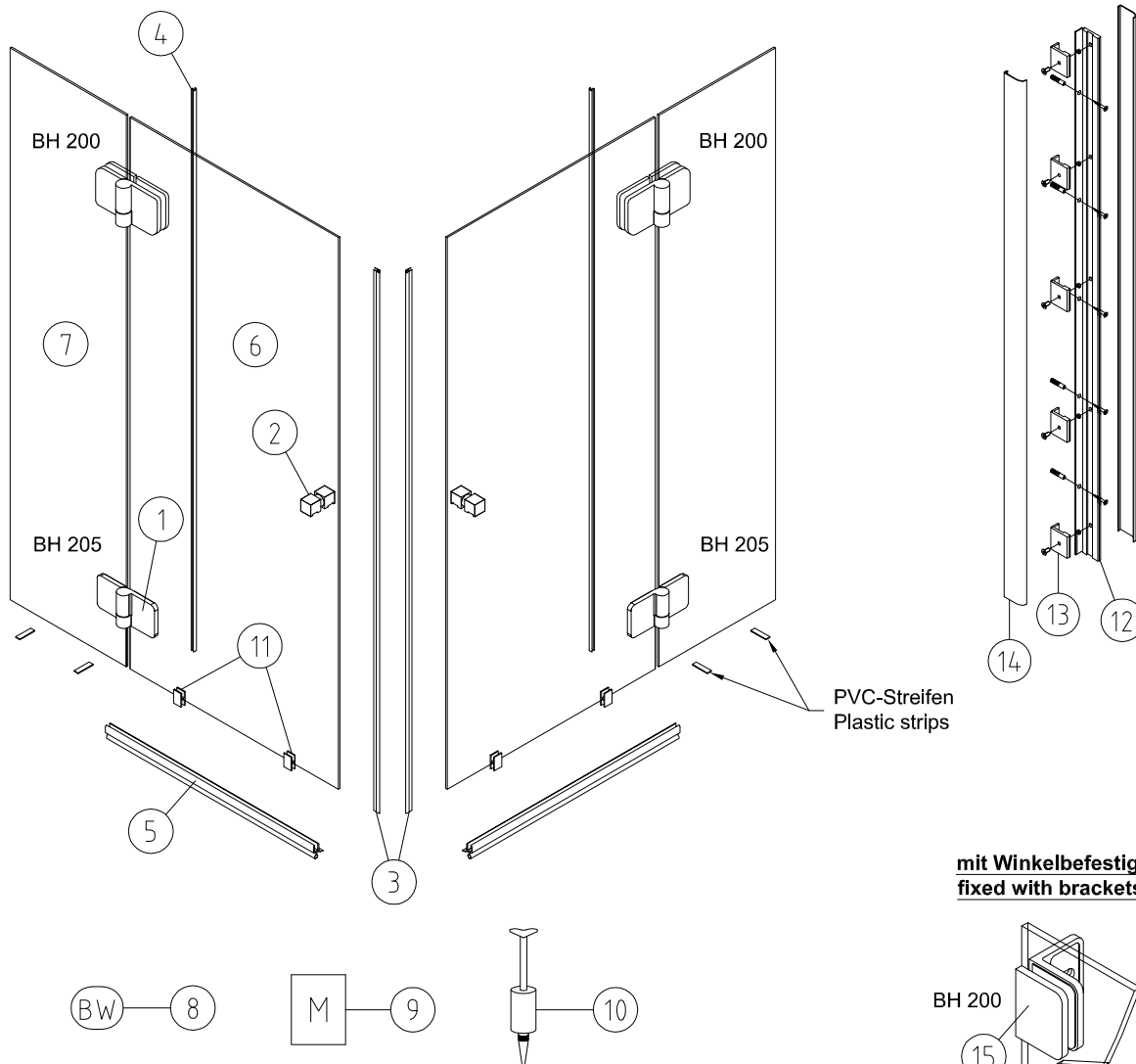

mit Winkelbefestigung:
fixed with brackets:

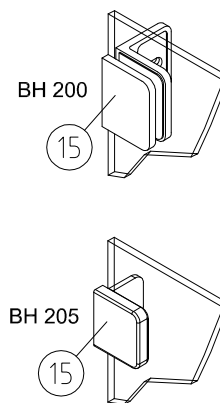

Material

- | | |
|--|---|
| ① Band Glas / Glas 180° / hinge glass / glass 180°
BH 200 mit Gegenplatte / BH 200 with counter plate
BH 205 mit Versenk / BH 205 with countersenk | 4 |
| ② Türkнопf / door knob | 2 |
| ③ Paar Magnetdichtung 90° KS / pair of magnetic seal 90° KS | 1 |
| ④ Mitteldichtung rund / middle seal round | 2 |
| ⑤ Wasserabweiser biegsam / water disperser flexible | 2 |
| ⑥ Glas Drehtür (optional) / glass swing door (optional) | 2 |
| ⑦ Glas Fixteil (optional) / glass in-line panel (optional) | 2 |
| ⑧ Beipack Wandbefestigung / fixtures enclosed | 1 |
| ⑨ Montageanleitung / mounting instruction | 1 |
| ⑩ Silikon-Katusche / silicon tube | 1 |
| ⑪ Montage Hilfe / assembly blocks | 4 |

Profilbefestigung / fixed with a profile

- | | |
|-------------------------------|----|
| ⑫ Klemmprofil / clamp profile | 2 |
| ⑬ Klemmstücke / clamps | 10 |
| ⑭ Clipsprofil / clips profile | 4 |
| oder / or | |

Winkelbefestigung / fixed with brackets

- | | |
|-----------------------------------|---|
| ⑮ Winkel G/W / bracket glass/wall | 4 |
|-----------------------------------|---|

Einbausituation Profilbefestigung:
Mounting arrangement fixed with a profile:

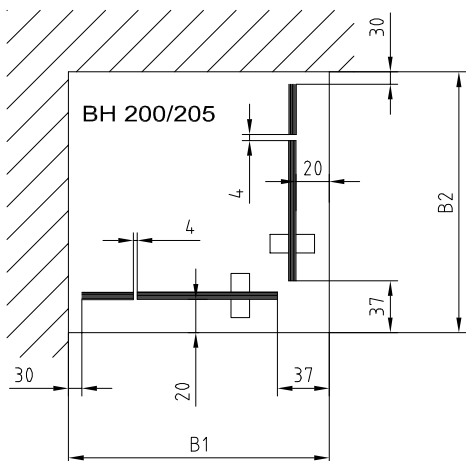

Einbausituation Winkelbefestigung:
Mounting arrangement fixed with bracket:

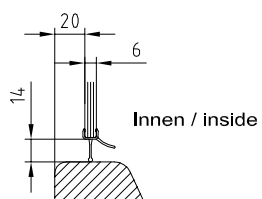
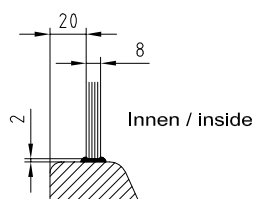
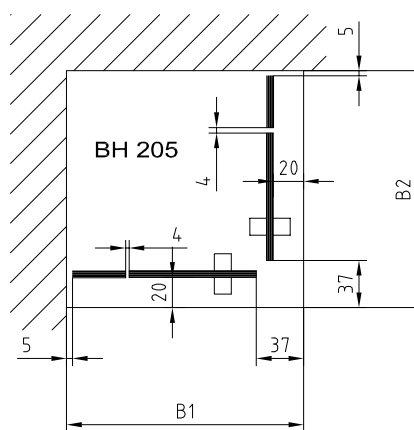
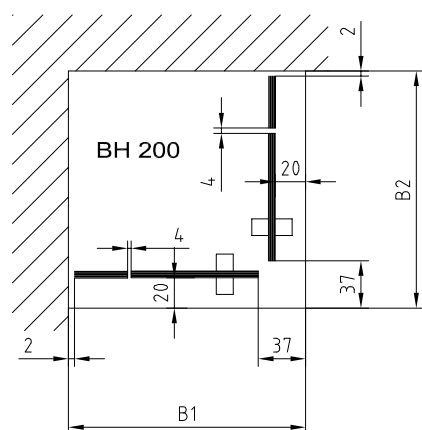

1A Winkelbefestigung / fixed with brackets

Winkel Glas/Wand an Fixteile schrauben.

Screw the brackets glass/wall onto in-line panels.

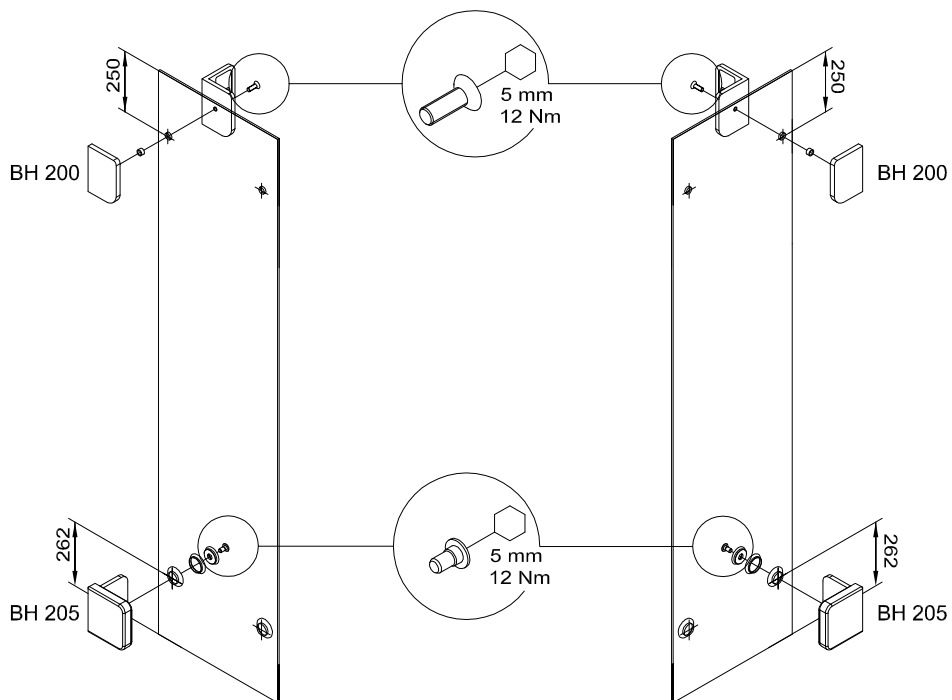

2A PVC-Streifen unterlegen. Fixteile ausrichten, anzeichnen, bohren und verschrauben.

Place the plastic strips under the glass.
Adjust in-line panels, mark, drill and screw on.

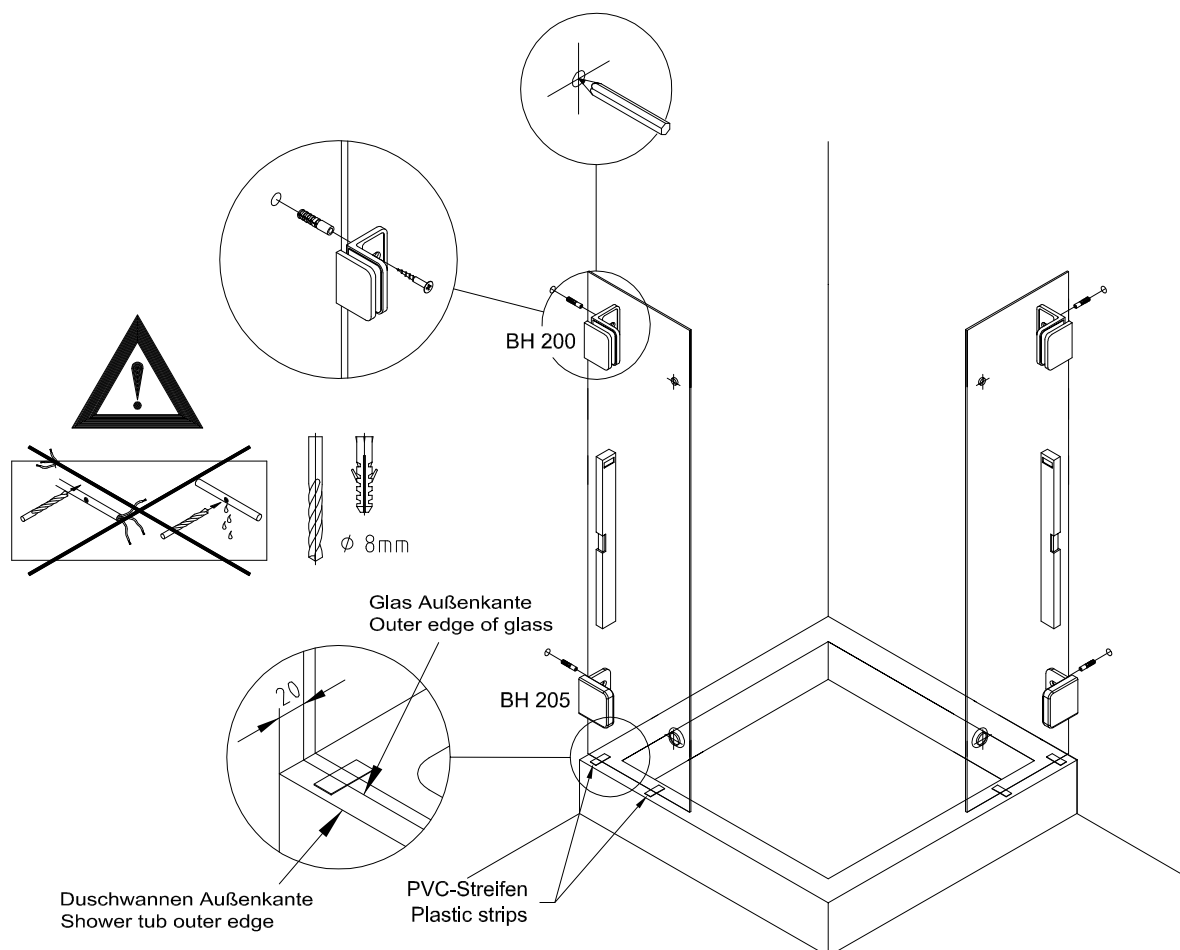

1B

Profilbefestigung / fixed with a profile

Klemmprofile ausrichten und Bohrungen anzeichnen.
Löcher bohren und Klemmprofile anschrauben.

Adjust clamp profiles and mark the drill holes.
Drill holes and install the clamp profiles.

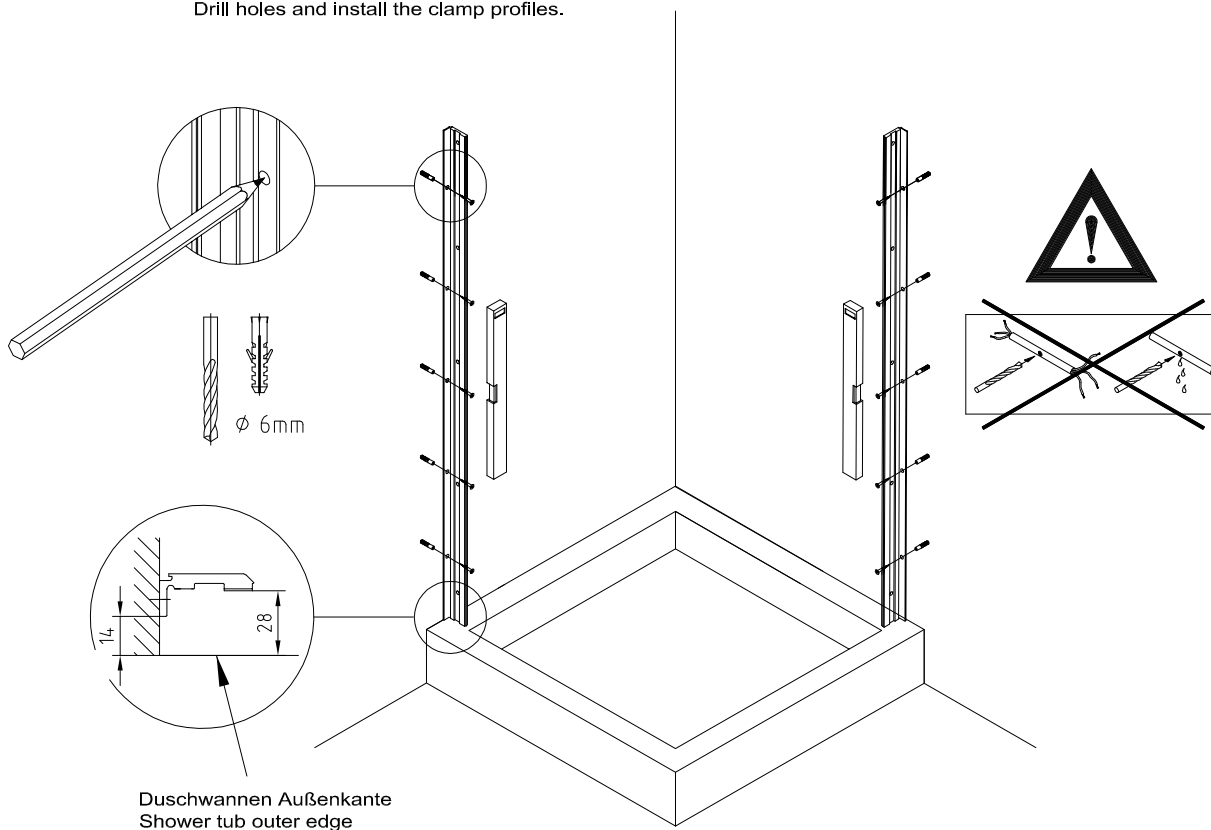

2B

PVC-Streifen unterlegen. Fixteile ausrichten und Klemmstücke anschrauben.

Place the plastic strips under the glass.
Adjust in-line panels and attach the clamps.

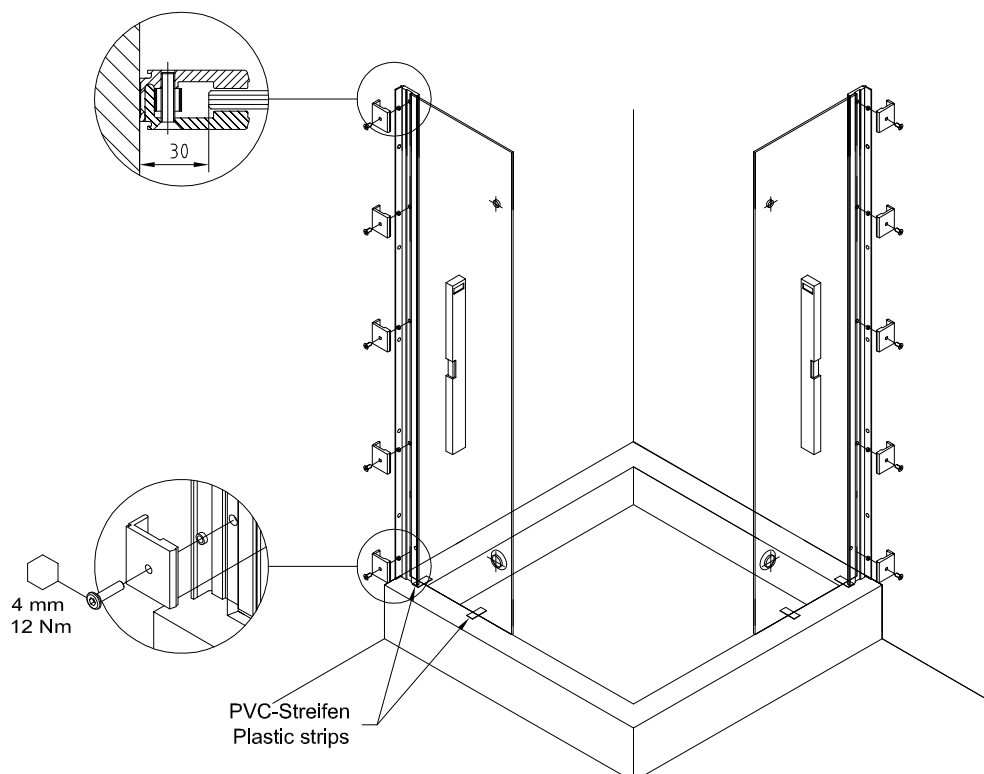

3

Bandunterteil an die Fixteile schrauben.
Screw on bottom hinge parts onto in-line panels.

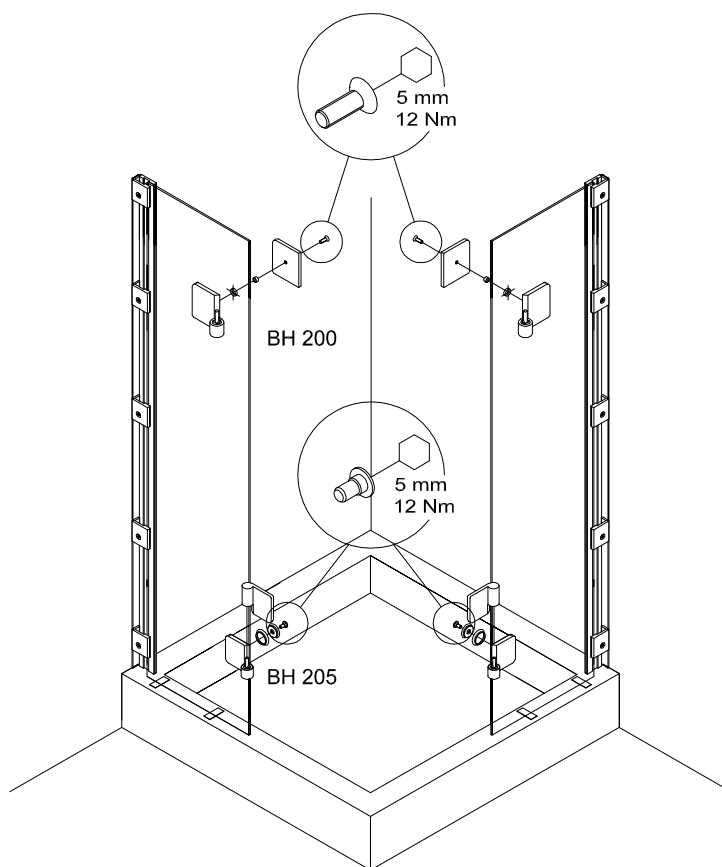

4

Bandoberteil an die Tür schrauben.
Knopf montieren, Magnetdichtung und Montagehilfen aufstecken.
Screw the top top hinge part onto glass door.
Screw on the door knob, attach the magnetic seal and the assembly blocks.

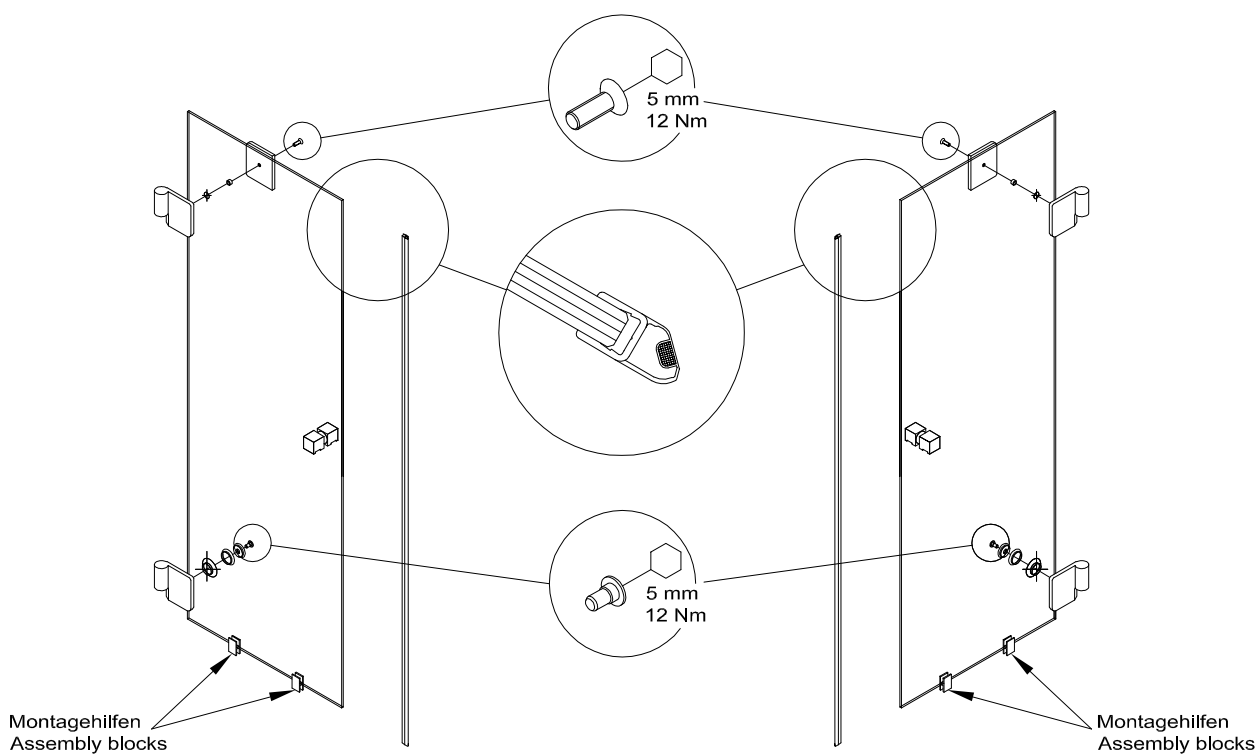

5

Drehtüren einhängen und ausrichten.

Fitting and adjustment of the swing door.

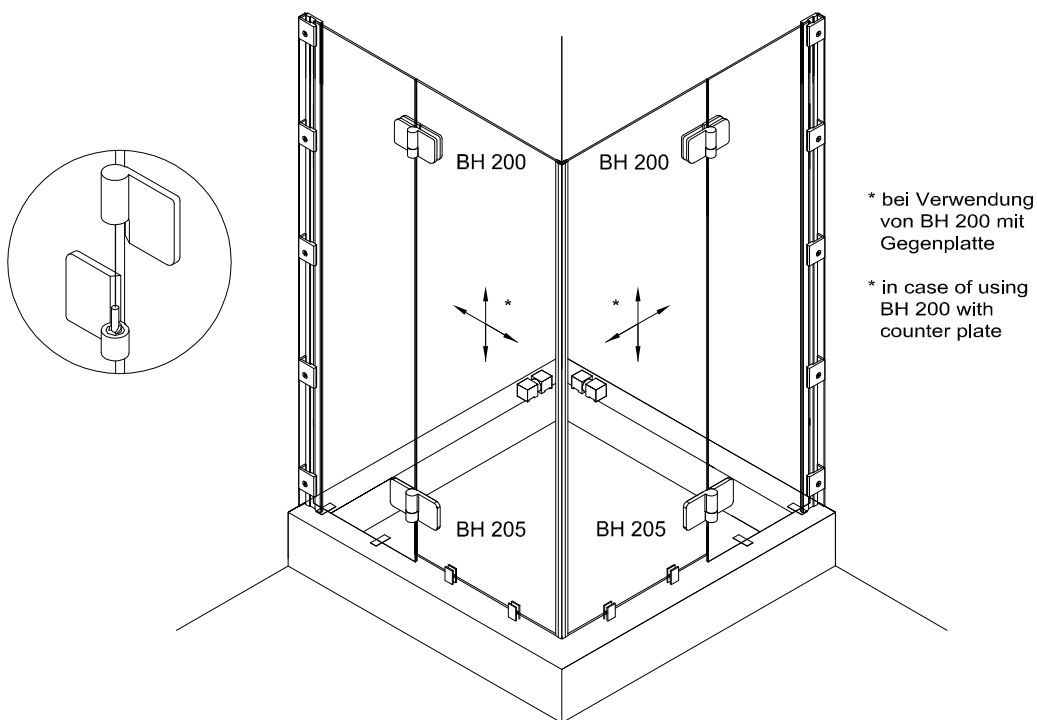

6

1. PVC-Streifen vorsichtig kürzen.
2. Clipsprofil aufstecken.
3. Montagehilfen entfernen.
Wasserabwäser und Mitteldichtung aufstecken.
4. Clipsprofile und Fixteile versiegeln.
5. kappen aufkleben.

1. Shorten plastic strips carefully.
2. Attach the clips profile.
3. Remove assembly blocks.
Attach water disperser and middle seal.
4. Seal up the clips profiles and the in-line panels.
5. glue on cover caps.

Profilbefestigung Fixed with profiles

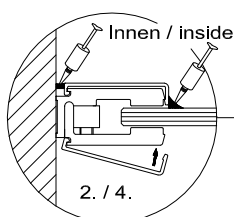

Winkelbefestigung Fixed with brackets

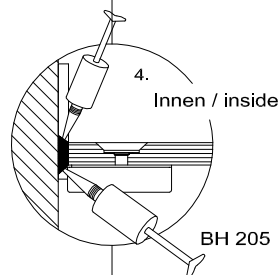

Winkelbefestigung Fixed with brackets

