

**Montageanleitung
BH 200/205 / TYP 255
Fünfeckkabine,
1 Drehtür an Fixteil,
1 Seitenteil**

**Assembly instruction
BH 200/205 / TYPE 255
pentangular cubicle,
1 swing door fixed to
in-line panel, 1 side panel**

Wichtige Informationen:
Important information:

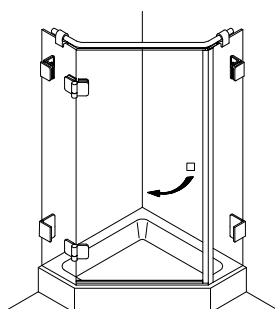

mit Winkelbefestigung
 fixed with brackets

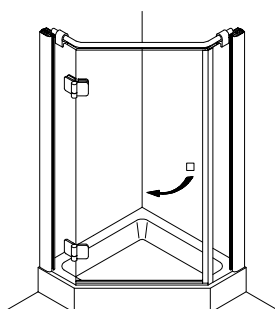

mit Profilbefestigung
 fixed with profiles

Vor der Montage Glasflächen
 mit handelsüblichem Glasreiniger
 im Bereich der Klemmflächen reinigen.

All glass clamping areas are to
 be cleaned with standard glass
 cleaning products prior to installation.



keine Verdünnung verwenden
 Do not use thinners

Wichtiger Hinweis

Glas beim Auspacken immer mit Schutz (Pappe oder Ähnlichem) auf den Fußboden stellen.
 Kanten und Ecken des Glases nicht anstoßen lassen.
 Konstruktionsbedingt ist bei rahmenlosen Duschatbrennungen keine absolute Abdichtung erreichbar.
 Die Montage der jeweils beiliegenden Dichtlippen gewährleistet die maximal erreichbare Dichtigkeit.
 Alle Maßangaben in mm!

Important notice!

While unpacking the glass always use the protection of the wood or cardboard, as available and
 set it on the floor. Be careful not to bump into anything with the trim and edges of the glass.
 Because of the construction of the frameless shower enclosure a complete seal cannot be obtained.
 The installation of the enclosed seals provide the maximal obtainable sealant.
 All measurements are in mm.

Montagewerkzeug:
Mounting tool:

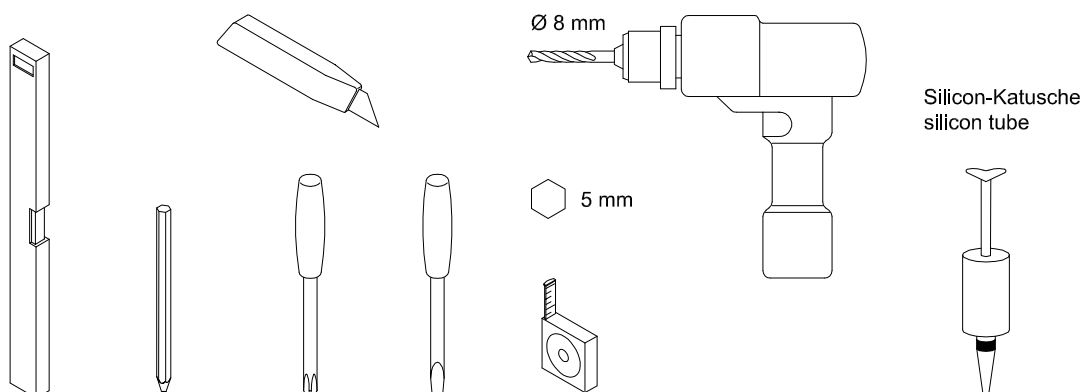

Lieferumfang:
Scope of delivery:

DIN links wie gezeichnet / DIN rechts spiegelbildlich
DIN left shown / DIN right in mirror image

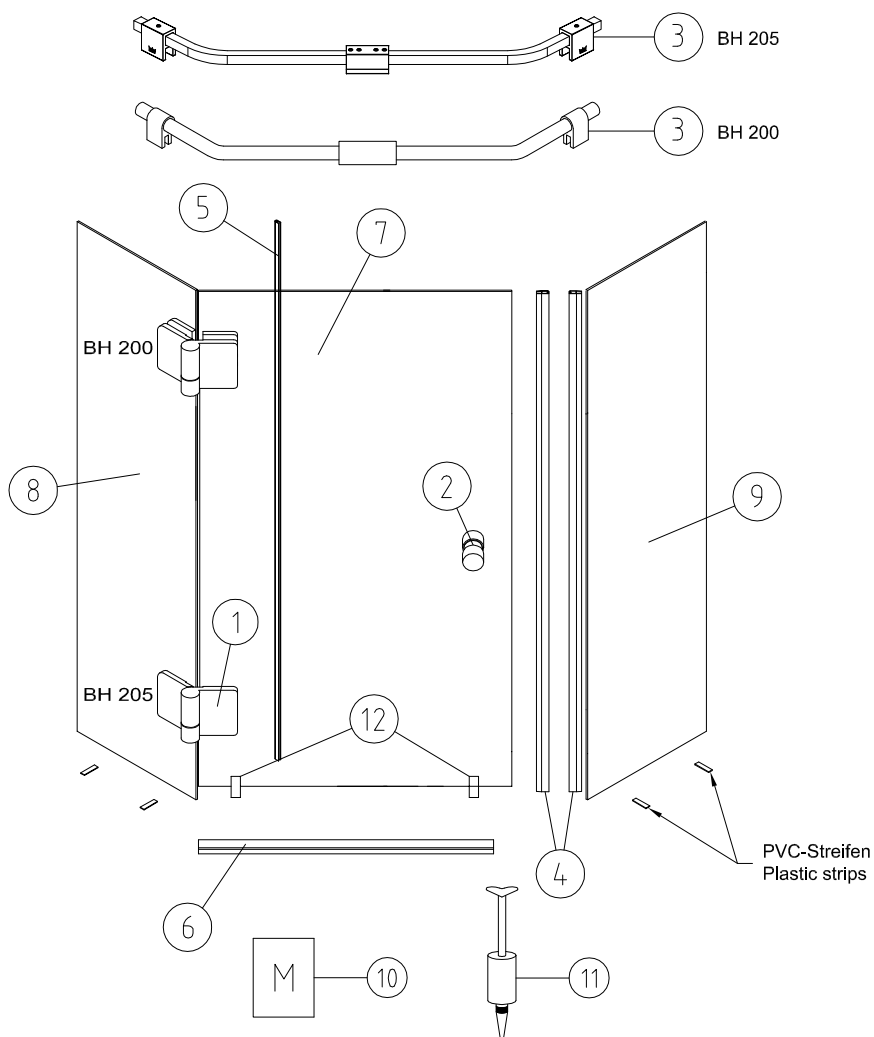

mit Profilbefestigung:
fixed with profile:

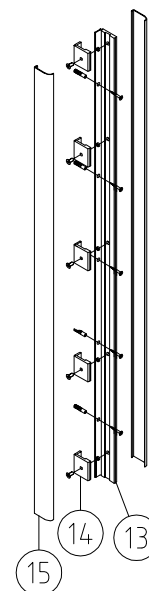

mit Winkelbefestigung:
fixed with brackets:

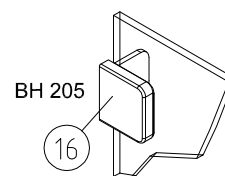
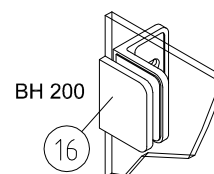

Material

① Band G/G 135° / glass/glass hinge 135°	2
② Türkнопf / door knob	1
③ Haltestange / universal support bar	1
④ Paar Magnetdichtung 135° / pair of magnetic seal 135°	1
⑤ Schlauchdichtung / soft nose seal	1
⑥ Wasserabweiser biegsam / water disperser flexible	1
⑦ Glas Drehtür (optional) / glass swing door (optional)	1
⑧ Glas Fixteil (optional) / glass in-line panel (optional)	1
⑨ Glas Seitenteil (optional) / glass side panel (optional)	1
⑩ Montageanleitung / assembly instruction	1
⑪ Silikon-Katusche / silicon tube	1
⑫ Montage Hilfe / assembly blocks	2

Profilbefestigung / fixed with profile

⑬ Klemmprofil / clamp profile	2
⑭ Klemmstücke / clamps	10
⑮ Clipsprofil / clips profile	4

oder / or

Winkelbefestigung / fixed with brackets

⑯ Winkel G/W / glass/wall bracket	4
-----------------------------------	---

Einbausituation Profilbefestigung:
Mounting arrangement fixed with profile:

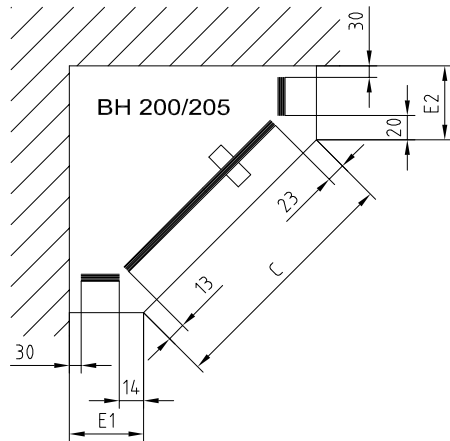

Einbausituation Winkelbefestigung:
Mounting arrangement fixed with bracket:

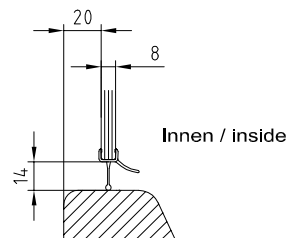
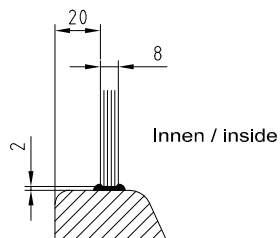
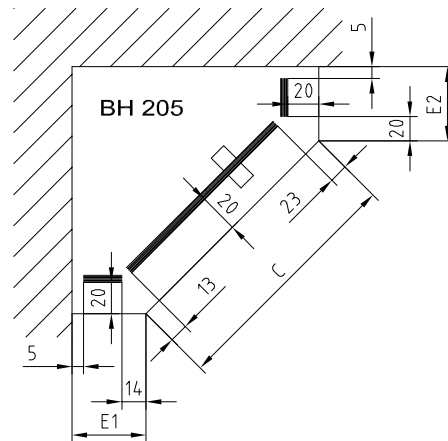
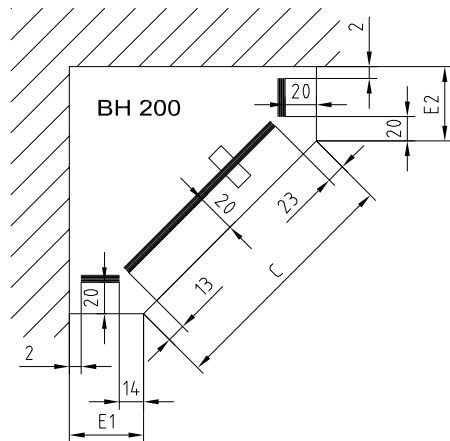

1A

Winkelbefestigung / fixed with brackets

Winkel Glas/Wand an das Glas schrauben.

Screw the brackets glass/wall onto the glass.

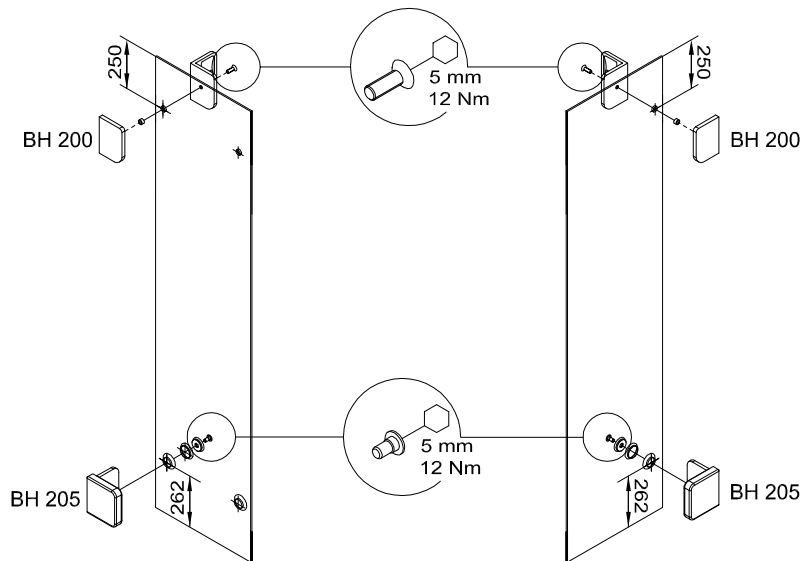

2A

PVC-Streifen unterlegen.

Fixteil und Seitenteil ausrichten, anzeichnen, bohren und verschrauben.

Place the plastic strips under the glass.

Adjust the in-line and side panel, mark, drill and screw on.

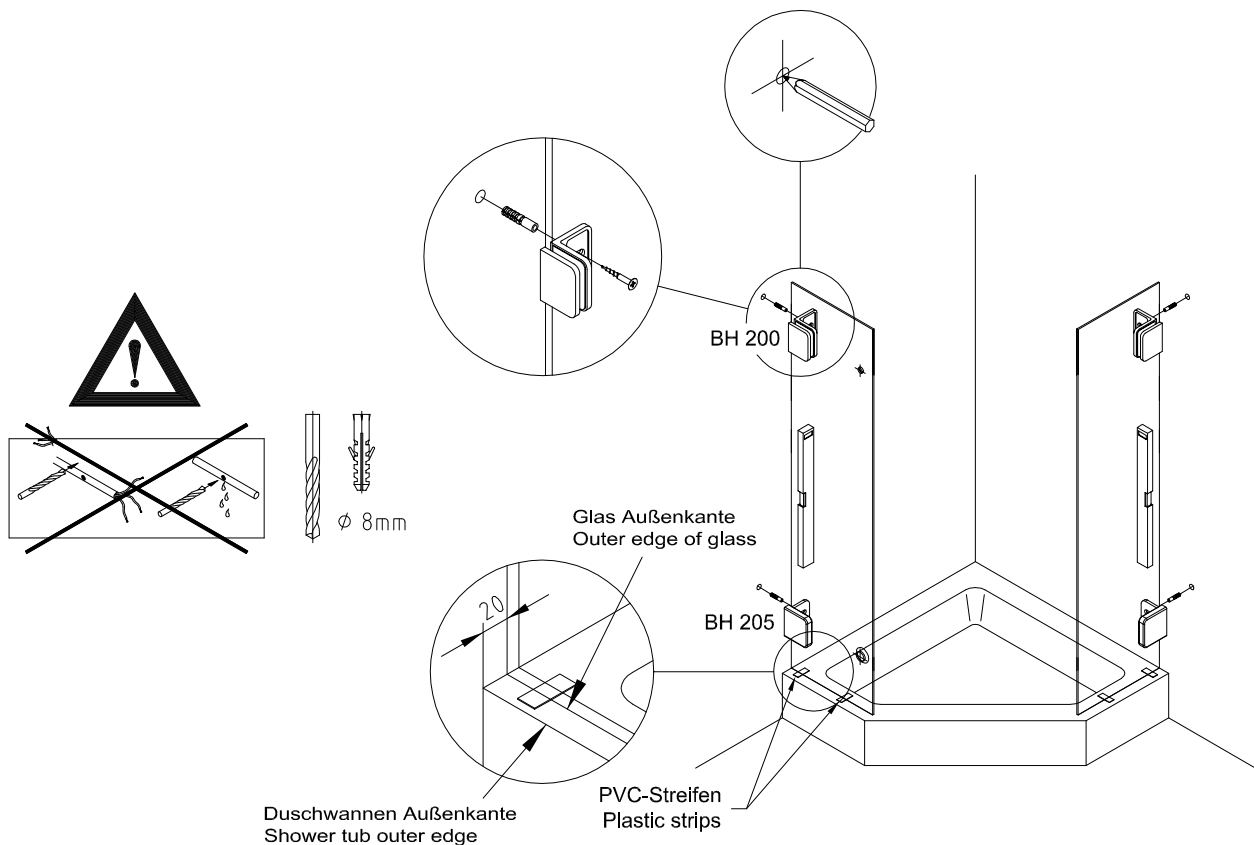

1B Profilbefestigung / fixed with profile

Klemmprofile ausrichten und Bohrungen anzeichnen.
Löcher bohren und Klemmprofile anschrauben.

Set up clamp profiles and mark the drill holes.
Drill holes and fix the clamp profiles.

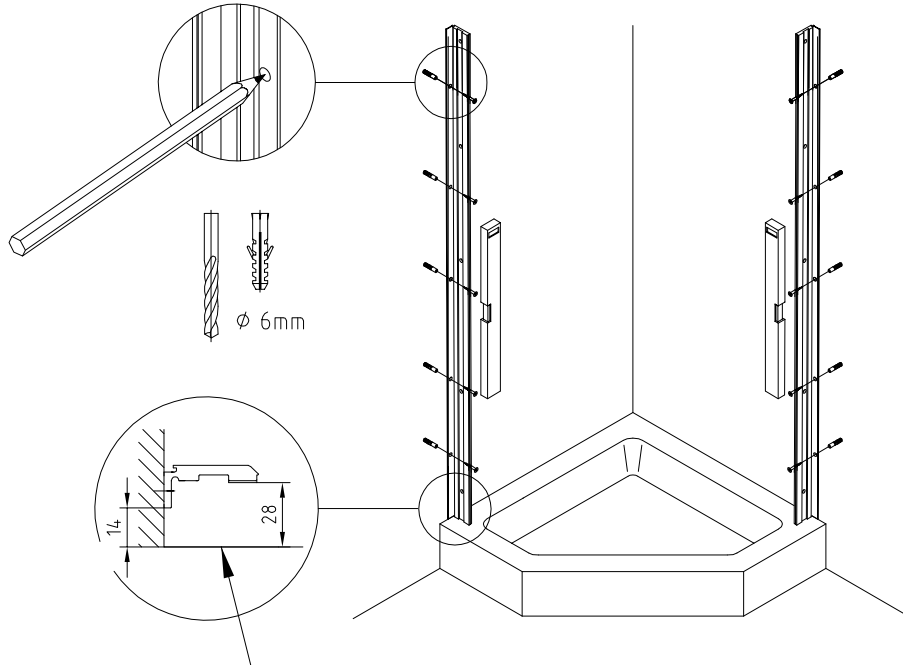

Duschwannen Außenkante
Shower tub outer edge

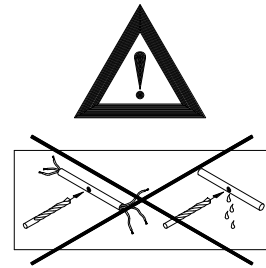

2B

Fixteil und Seitenteil ausrichten und Klemmstücke anschrauben.

Set up in-line and side panel and screw on the clamps.

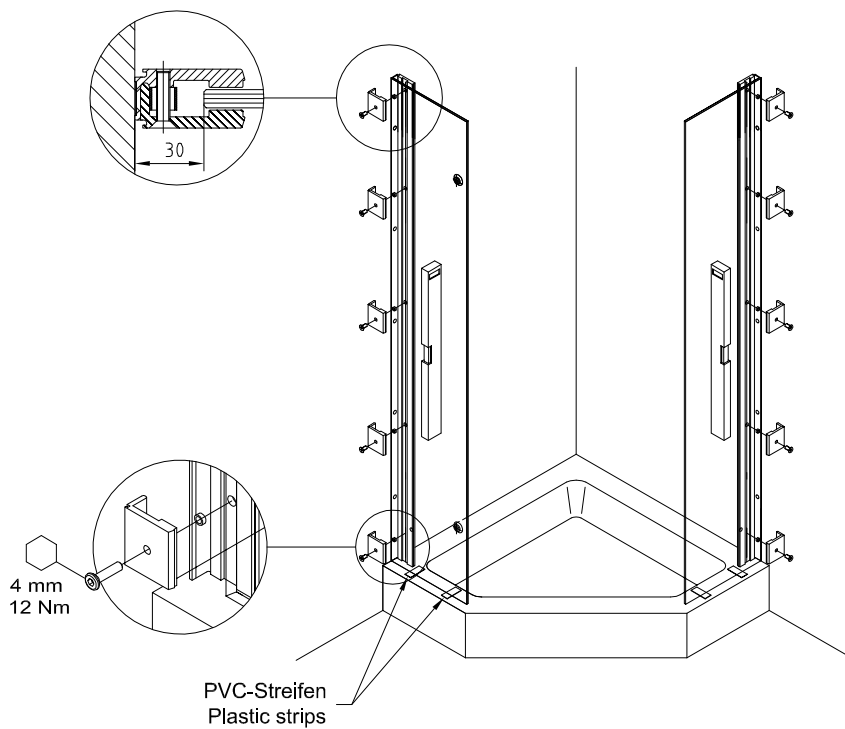

3

Bänder Glas/Glas an das Fixteil schrauben.

Screw on hinges glass/glass onto the in-line panel.

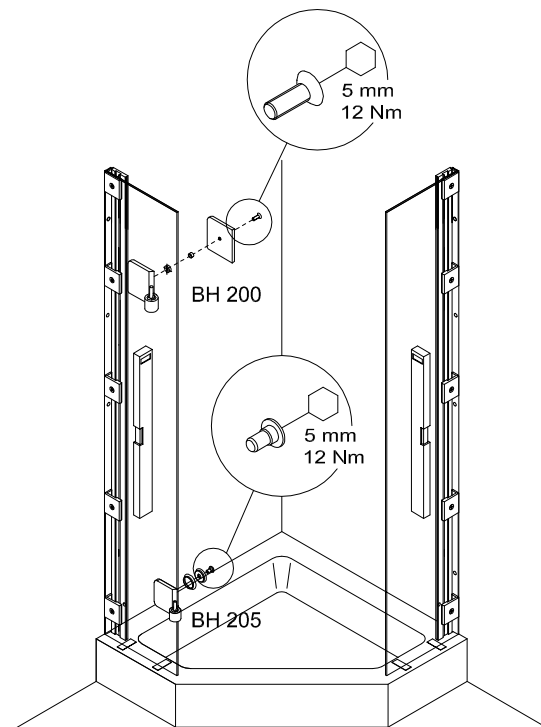

4

Bandoberteil an die Tür schrauben.

Knopf montieren, Magnetdichtung und Montagehilfen aufstecken.

Screw the top top hinge part onto glass door.

Screw on the door knob, attach the magnetic seal and the assembly blocks.

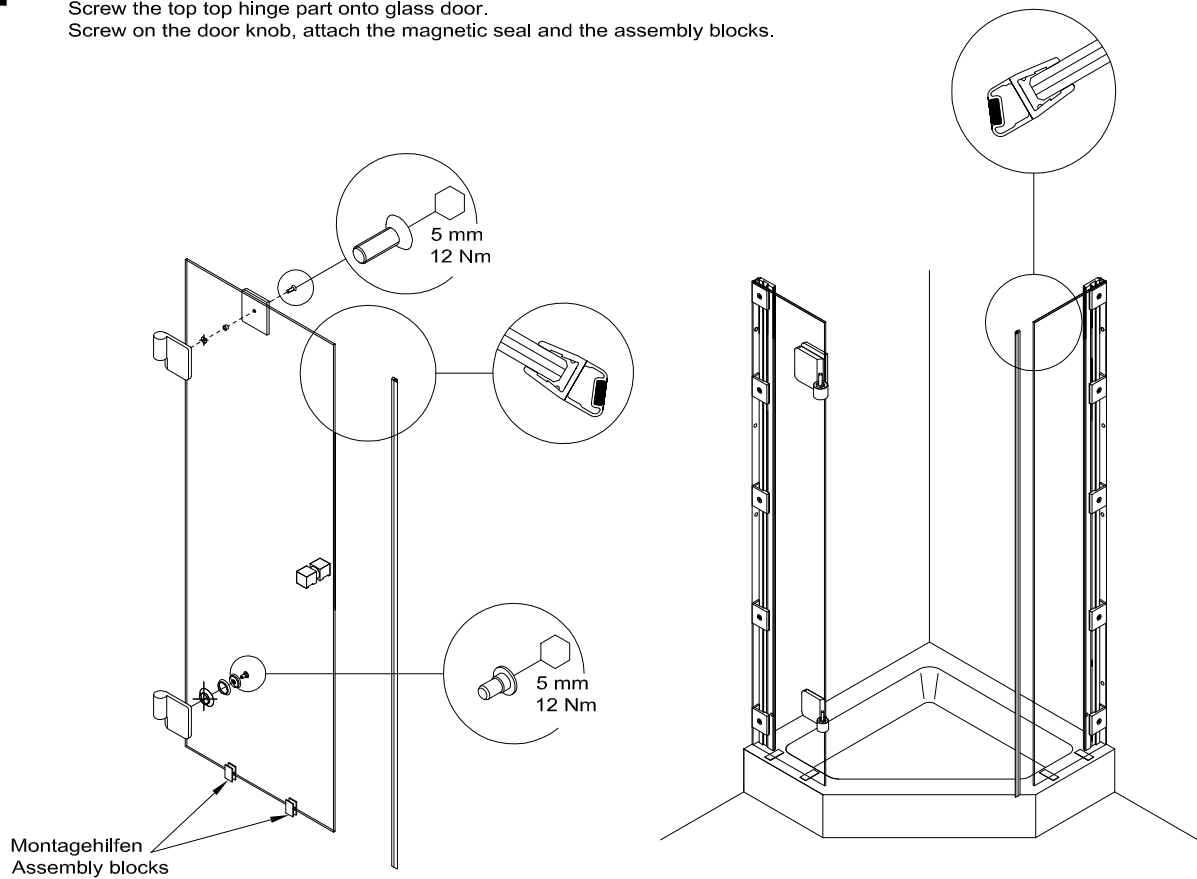

5

Drehtüren einhängen und ausrichten.
Fitting and adjustment of the swing door.

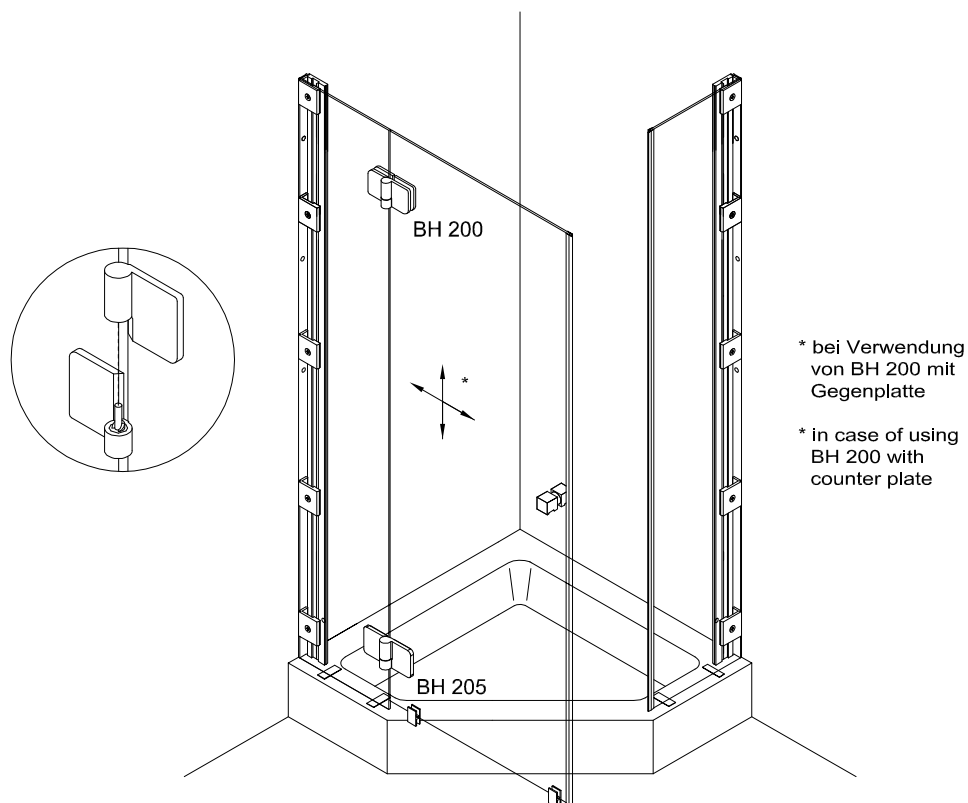

6

Montage der Haltestange BH 200.
Installation of universal support bar BH 200.

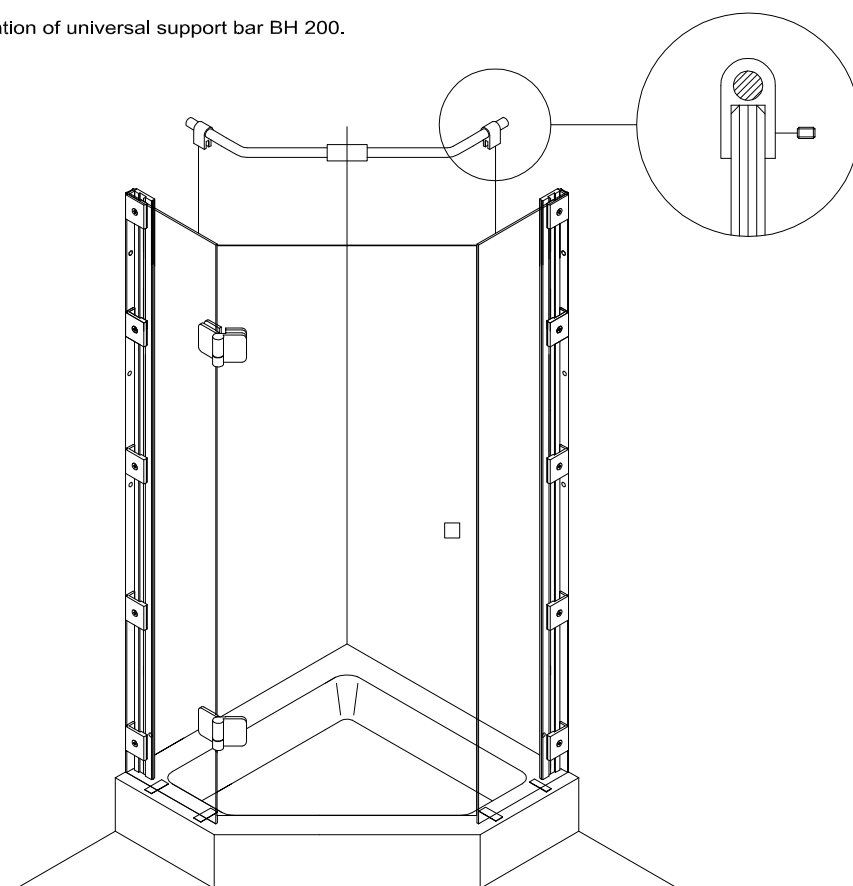

6

1. PVC-Streifen vorsichtig kürzen.
2. Clipsprofile aufstecken.
3. Montagehilfen entfernen.
Wasserabweser und Mitteldichtung aufstecken.
4. Clipsprofile und Fixteile versiegeln.
5. Montage der Haltestange.

1. Shorten plastic strips carefully.
2. Attach the clips profiles.
3. Take of assembly blocks.
Attach water disperser and middle seal.
4. Seal up the clips profiles and the fixed panels.
5. Installation of support bar.



Montage der Haltestange BH 205, siehe separate Montageanleitung 800.52.390.6.32



Installation of support bar BH 205, please see separate installation instruction 800.52.390.6.32

