

**Montageanleitung
BH 200/205 / TYP 260
Viertelkreiskabine, 2
gebogene Drehtüren an
Fixteilen, mit Winkel-/
Profilbefestigung**

**Assembly instruction
BH 200/205 / TYPE 260
Curved shower enclosure with
two curved glass swing doors
fixed to in-line panels,
fixed with brackets/profiles**

Wichtige Informationen:
Important information:

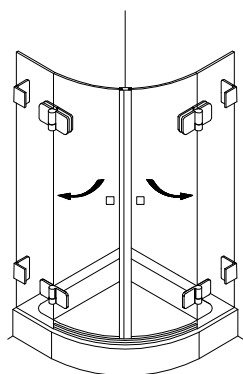

mit Winkelbefestigung
 fixed with brackets

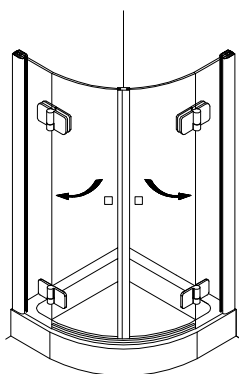

mit Profilbefestigung
 fixed with profiles

Vor der Montage Glasflächen mit handelsüblichem Glasreiniger im Bereich der Klemmflächen reinigen.

All glass clamping areas are to be cleaned with standard glass cleaning products prior to installation.



keine Verdünnung verwenden
 Do not use thinners

Wichtiger Hinweis

Glas beim Auspacken immer mit Schutz (Pappe oder Ähnlichem) auf den Fußboden stellen. Kanten und Ecken des Glases nicht anstoßen lassen. Konstruktionsbedingt ist bei rahmenlosen Duschatbrennungen keine absolute Abdichtung erreichbar. Die Montage der jeweils beiliegenden Dichtlippen gewährleistet die maximal erreichbare Dichtigkeit. Alle Maßangaben in mm!

Important notice!

While unpacking the glass always use the protection of the wood or cardboard, as available and set it on the floor. Be careful not to bump into anything with the trim and edges of the glass. Because of the construction of the frameless shower enclosure a complete seal cannot be obtained. The installation of the enclosed seals provide the maximal obtainable sealant. All measurements are in mm.

Montagewerkzeug:
Mounting tool:

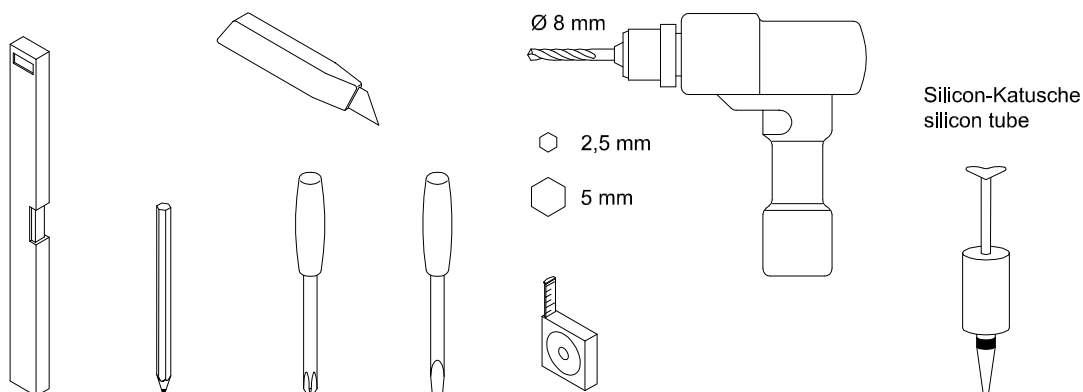

Lieferumfang:
Scope of delivery:

BH 200
mit Gegenplatte
with counter plate



BH 205
mit Versenk
with countersenk



mit Profilbefestigung:
fixed with profile:

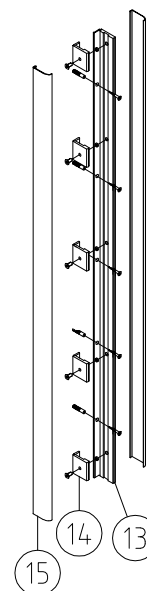
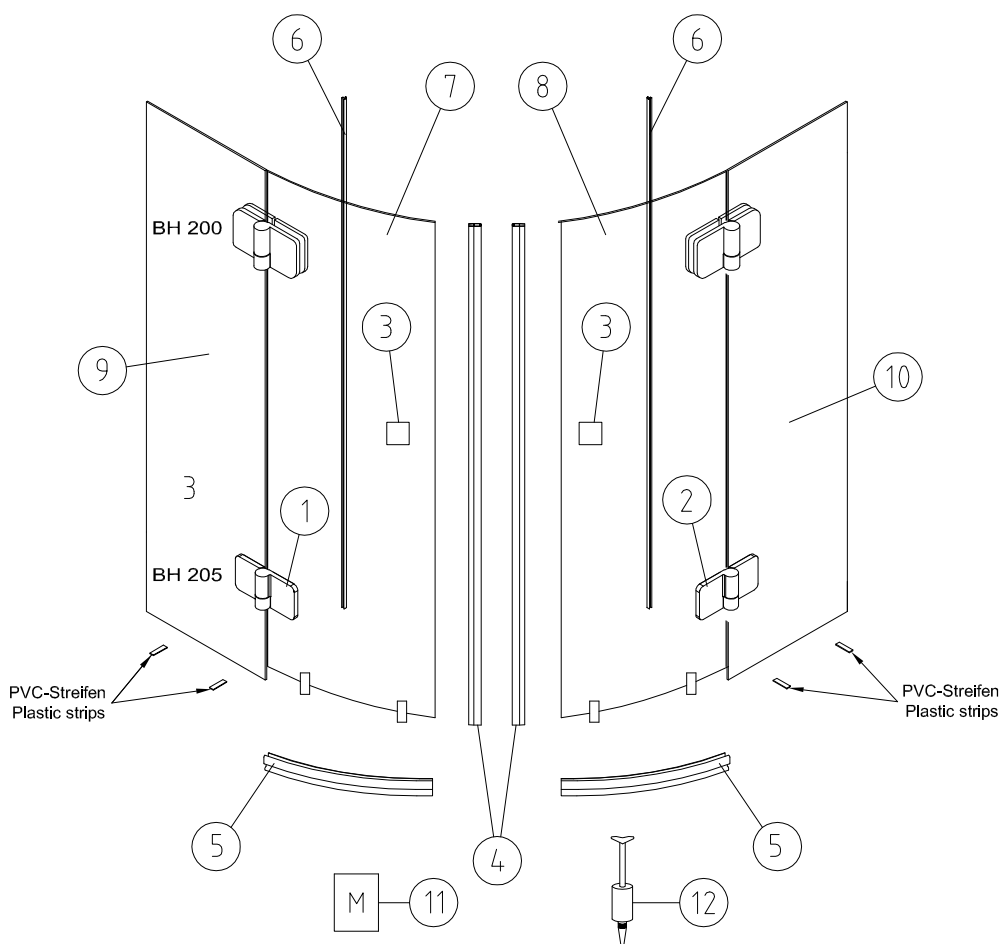

mit Winkelbefestigung:
fixed with brackets:

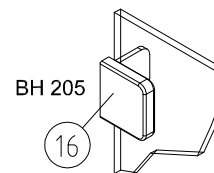
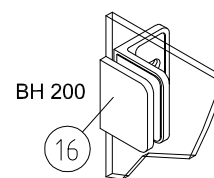

Material

① Band G/G links / glass/glass hinge LH	2
② Band G/G rechts / glass/glass hinge RH	2
③ Türkнопf / door knob	2
④ Paar Magnetdichtung 180° KS / pair of magnetic seal 180° KS	1
⑤ Wasserabweiser biegsam / water disperser flexible	2
⑥ Mitteldichtung 135° / middle seal 135°	2
⑦ Glas Drehtür links (optional) / glass swing door LH (optional)	1
⑧ Glas Drehtür rechts (optional) / glass swing door RH (optional)	1
⑨ Glas Fixteil links (optional) / glass fixed panel LH (optional)	1
⑩ Glas Fixteil rechts (optional) / glass fixed panel RH (optional)	1
⑪ Montageanleitung / assembly instruction	1
⑫ Silikon Katusche / silicon tube	1

Profilbefestigung / fixed with profile

⑬ Klemmprofil / clamp profile	2
⑭ Klemmstücke / clamps	10
⑮ Clipsprofil / clips profile	4

oder / or

Winkelbefestigung / fixed with brackets

⑯ Winkel G/W / glass/wall bracket	4
-----------------------------------	---

Einbausituation Profilbefestigung:
Mounting arrangement fixed with profile:

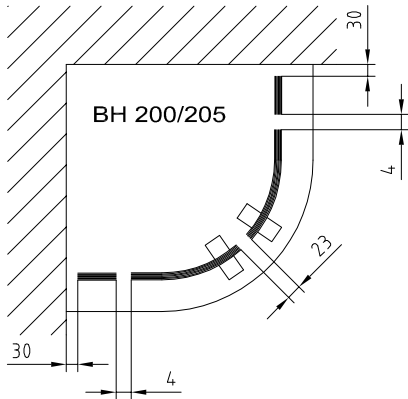

Einbausituation Winkelbefestigung:
Mounting arrangement fixed with bracket:

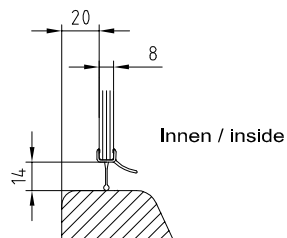
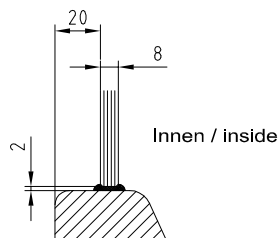
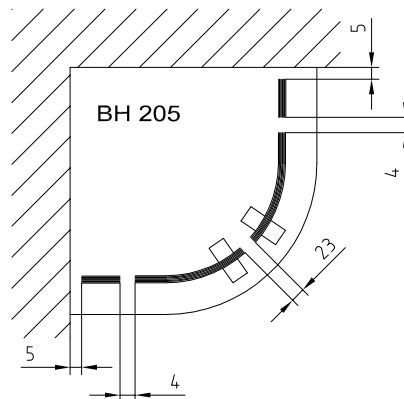
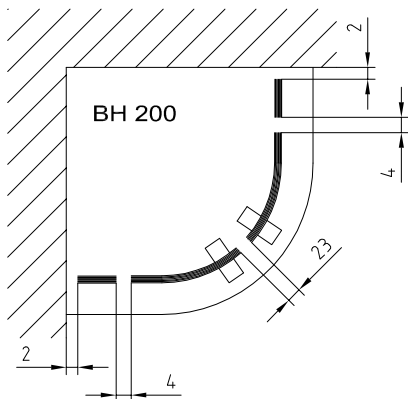

1A

Winkelbefestigung / fixed with brackets

Winkel Glas/Wand an Fixteile schrauben.

Screw the brackets glass/wall onto in-line panels.

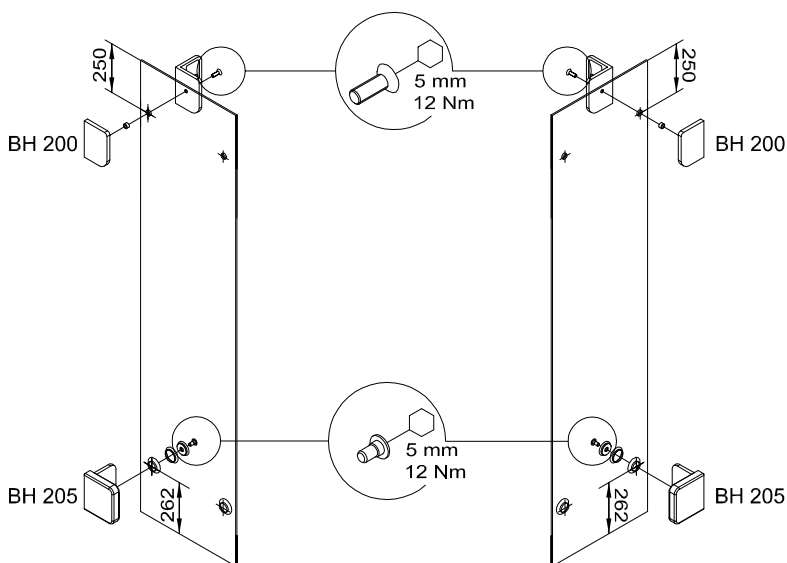

2A

PVC-Streifen unterlegen.

Fixteile ausrichten, anzeichnen, bohren und verschrauben.

Place the plastic strips under the glass.

Adjust in-line panels, mark, drill and screw on.

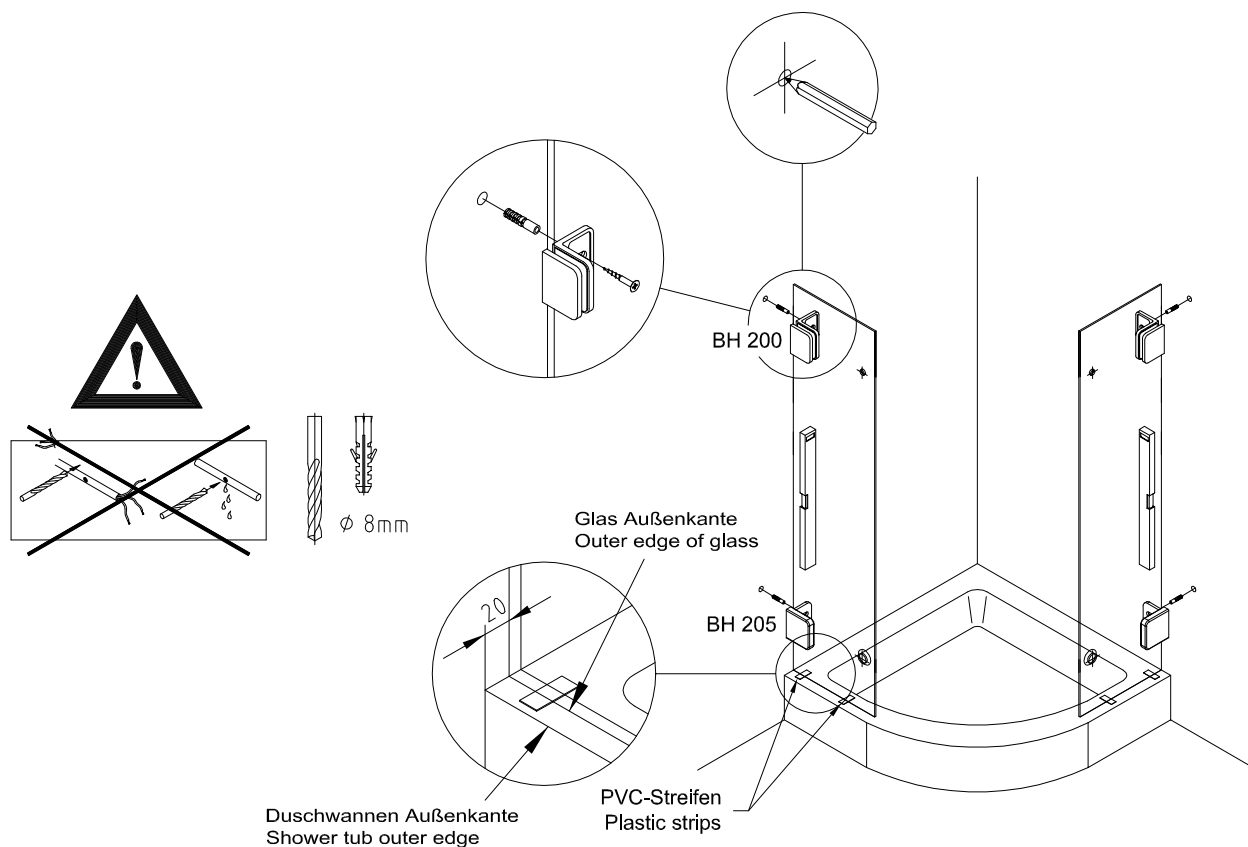

1B Profilbefestigung / fixed with profile

Klemmprofil ausrichten und Bohrungen anzeichnen.
Löcher bohren und Klemmprofil anschrauben.

Set up clamp profile and mark the drill holes.
Drill holes and fix the clamp profile

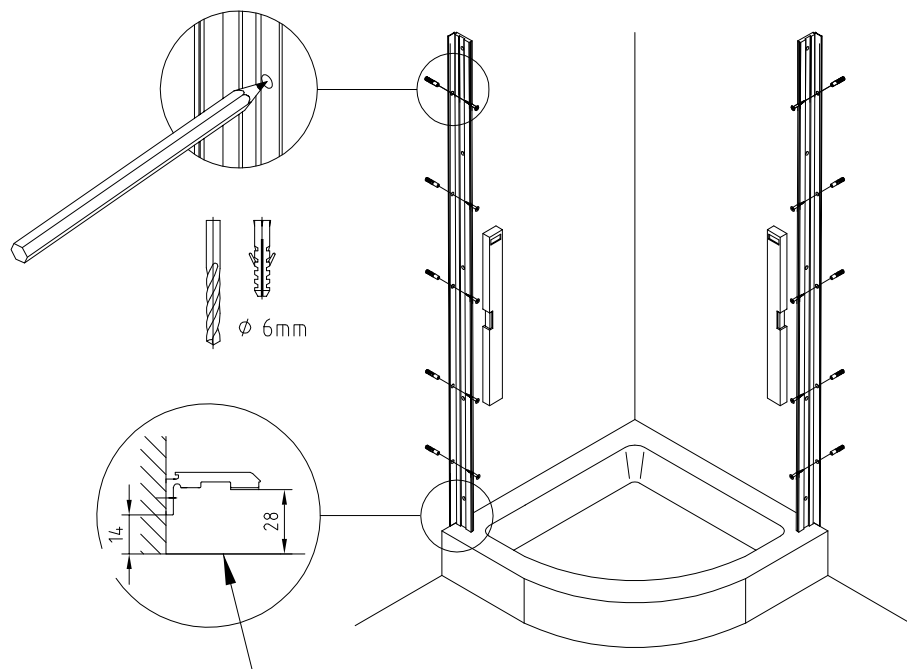

Duschkannen Außenkante
Shower tub outer edge

2B Seitenteil ausrichten und Klemmstücke anschrauben.

Set up side panel and screw on the clamps.

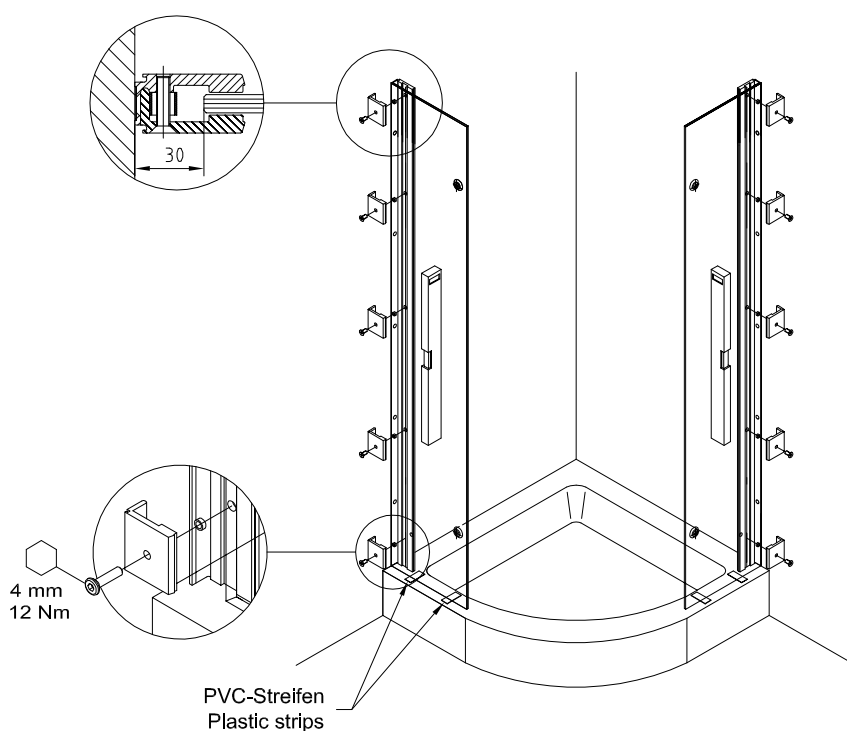

3

Bänder Glas/Glas an Fixteil schrauben.

Screw on hinges glass/glass onto fixed panel.

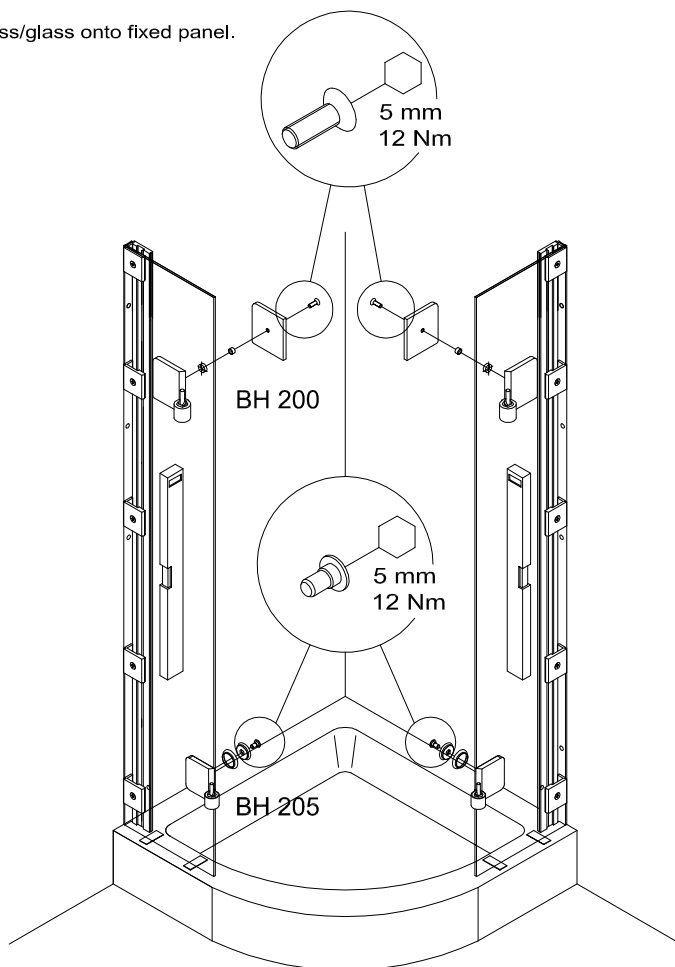

4

Bandoberteil an die Tür schrauben.

Knopf montieren, Magnetdichtung und Montagehilfen aufstecken.

Screw the top top hinge part onto glass door.

Screw on the door knob, attach the magnetic seal and the assembly blocks.

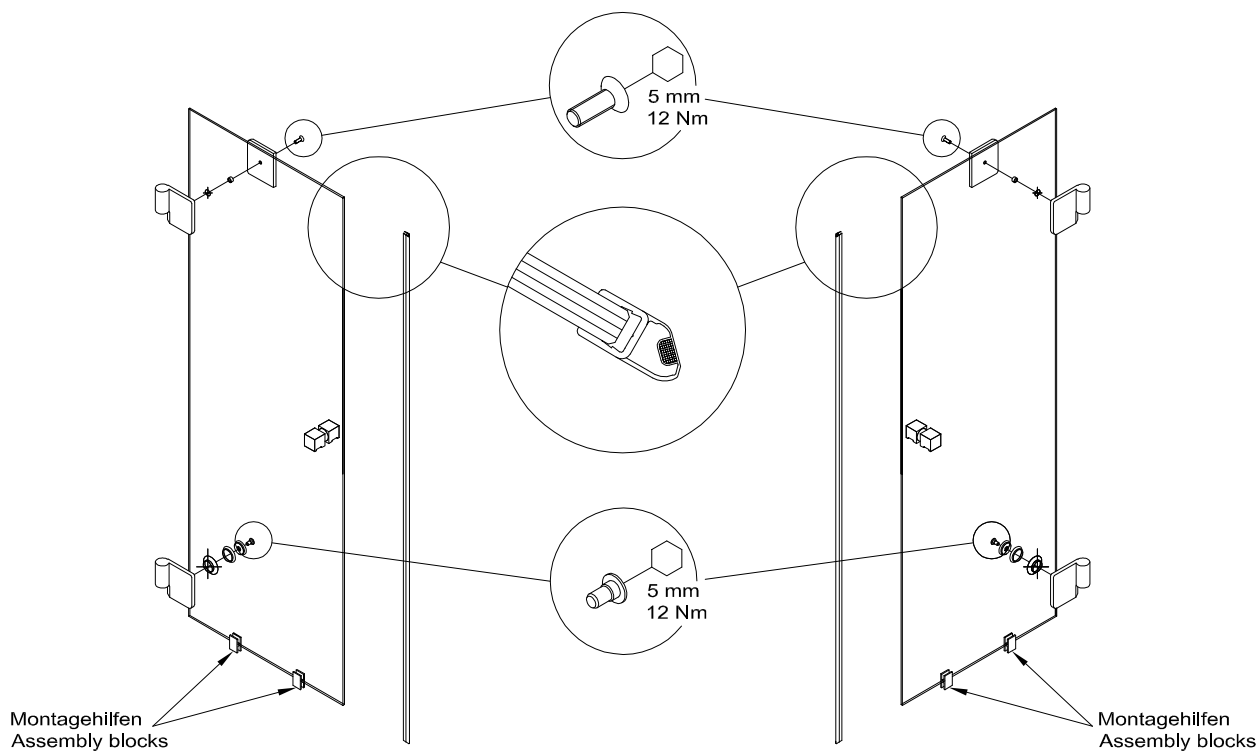

5

Drehtüren einhängen und ausrichten.

Fitting and adjustment of the swing door.

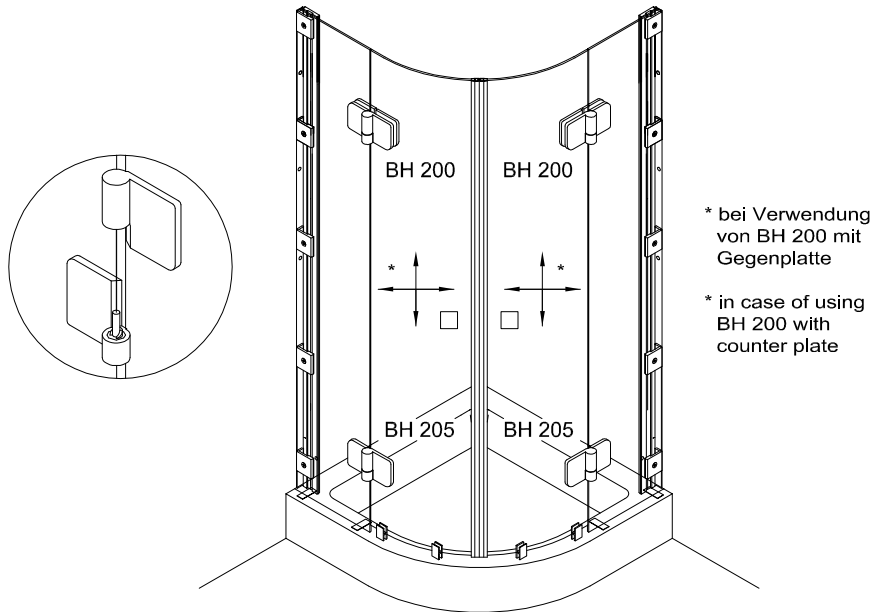

6

1. PVC-Streifen vorsichtig kürzen.
2. Clipsprofile aufstecken.
3. Montagehilfen entfernen.
Wasserabwäser und Mitteldichtung aufstecken.
4. Clipsprofile und Fixteile versiegeln.
5. Montage der Haltestange.

1. Shorten plastic strips carefully.
2. Attach the clips profiles.
3. Take of assembly blocks.
Attach water disperser and middle seal.
4. Seal up the clips profiles and the fixed panels.
5. Installation of support bar.

Profilbefestigung Fixed with profiles

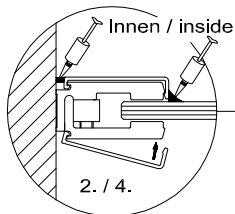

Winkelbefestigung Fixed with brackets

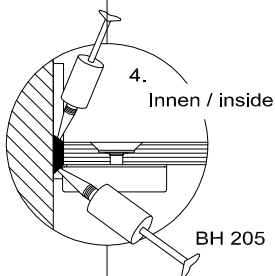

Winkelbefestigung Fixed with brackets

