

**Montageanleitung
BO 381 / TYP 250
Fünfeckkabine, 2 Drehtüren
an Fixteilen, mit Winkel-/
Profilbefestigung**

**Assembly instruction
BO 381 / TYPE 250
pentangular cubicle, 2 swing
doors fixed to in-line panels,
fixed with brackets/profiles**

Wichtige Informationen:
Important information:

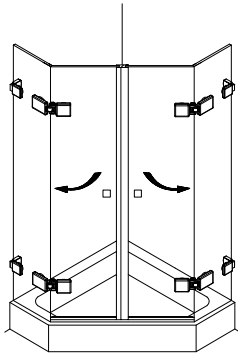

mit Winkelbefestigung
 fixed with brackets

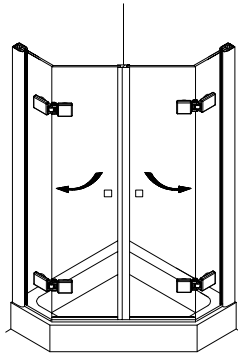

mit Profibefestigung
 fixed with profiles

Vor der Montage Glasflächen mit handelsüblichem Glasreiniger im Bereich der Klemmflächen reinigen.

All glass clamping areas are to be cleaned with standard glass cleaning products prior to installation.



keine Verdünnung verwenden
 Do not use thinners

Wichtiger Hinweis

Glas beim Auspacken immer mit Schutz (Pappe oder Ähnlichem) auf den Fußboden stellen. Kanten und Ecken des Glases nicht anstoßen lassen. Konstruktionsbedingt ist bei rahmenlosen Duschatbrennungen keine absolute Abdichtung erreichbar. Die Montage der jeweils beiliegenden Dichtlippen gewährleistet die maximal erreichbare Dichtigkeit. Alle Maßangaben in mm!

Important notice!

While unpacking the glass always use the protection of the wood or cardboard, as available and set it on the floor. Be careful not to bump into anything with the trim and edges of the glass. Because of the construction of the frameless shower enclosure a complete seal cannot be obtained. The installation of the enclosed seals provide the maximal obtainable sealant. All measurements are in mm.

Montagewerkzeug:
Assembly tools:

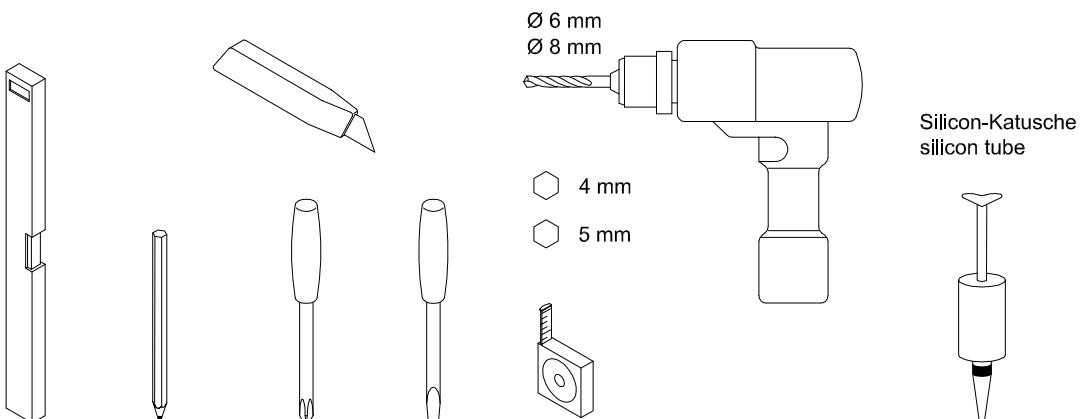

Lieferumfang:
Scope of delivery:

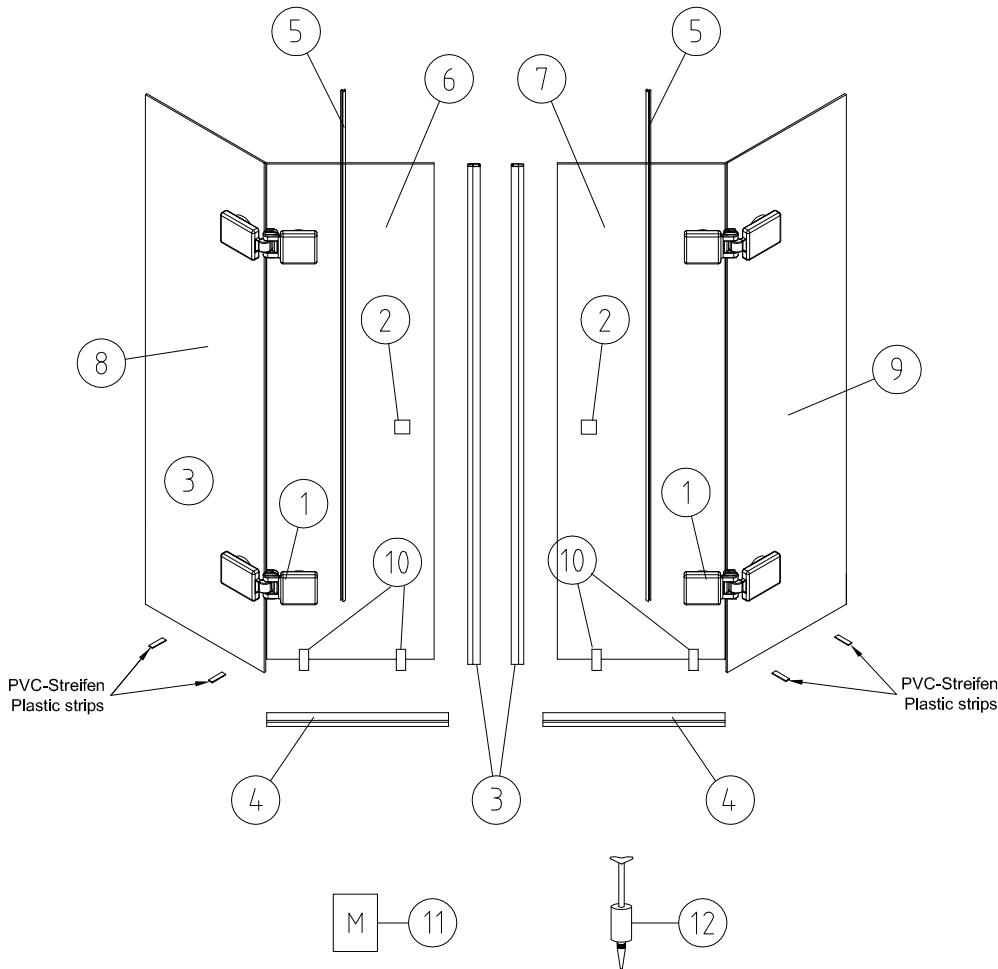

mit Profilbefestigung:
fixed with profile:

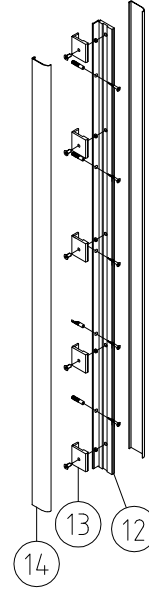

mit Winkelbefestigung:
fixed with brackets:

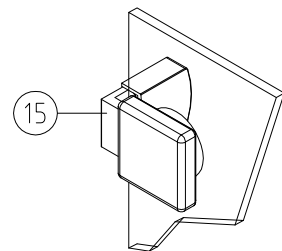

Material

① Band G/G 135° / glass/glass hinge 135°	4
② Türkнопf / door knob	2
③ Magnetchichtung 180° / magnetic seal 180°	1
④ Wasserabweiser biegsam / water disperser flexible	2
⑤ Mitteldichtung 135° / middle seal 135°	2
⑥ Glas Drehtür links (optional) / glass swing door LH (optional)	1
⑦ Glas Drehtür rechts (optional) / glass swing door RH (optional)	1
⑧ Glas Fixteil links (optional) / glass fixed panel LH (optional)	1
⑨ Glas Fixteil rechts (optional) / glass fixed panel RH (optional)	1
⑩ Montagehilfe / assembly blocks	4
⑪ Montageanleitung / assembly instruction	1
⑫ Silikon Katusche / silicon tube	1

Profilbefestigung / fixed with profile

⑫ Klemmprofil / clamp profile	2
⑬ Klemmstücke / clamps	10
⑭ Clipsprofil / clips profile	4

oder / or

Winkelbefestigung / fixed with brackets

⑮ Winkel G/W / glass/wall bracket	4
-----------------------------------	---

Einbausituation Profilbefestigung:
 Mounting arrangement fixed with profile:

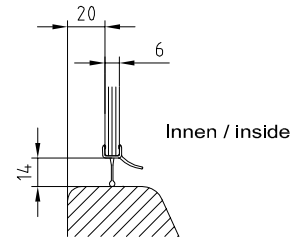
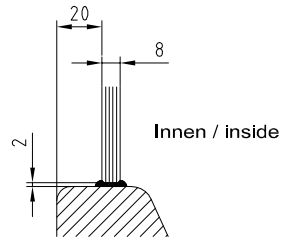
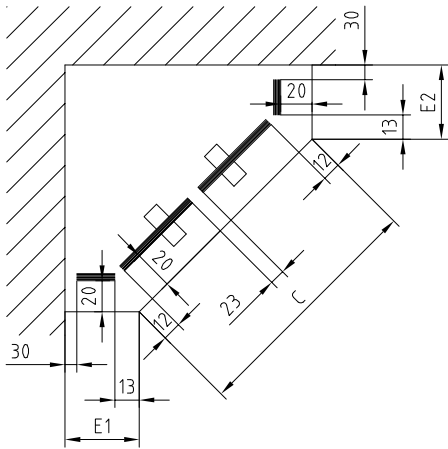

Einbausituation Winkelbefestigung:
 Mounting arrangement fixed with bracket:

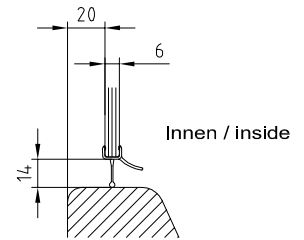
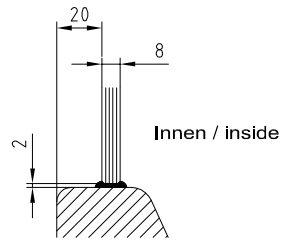
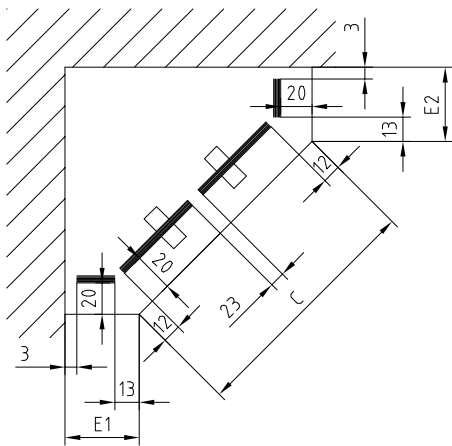

1A

Winkelbefestigung / fixed with brackets

Winkel Glas/Wand an Fixteil schrauben.

Screw the brackets glass/wall onto in-line panel.

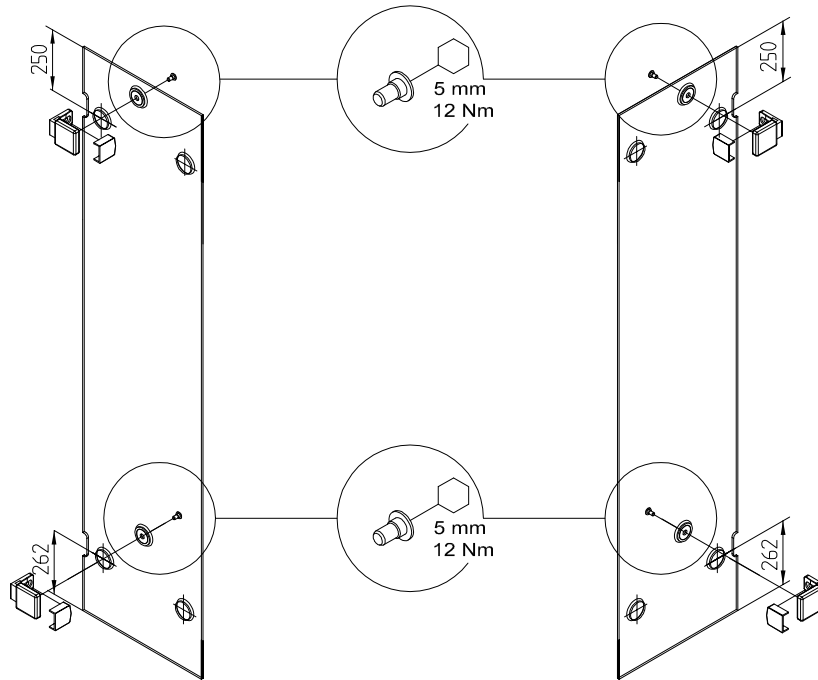

2A

PVC-Streifen unterlegen.

Fixteile ausrichten, anzeichnen, bohren und verschrauben.

Place the plastic strips under the glass.

Adjust in-line panels, mark, drill and screw on.

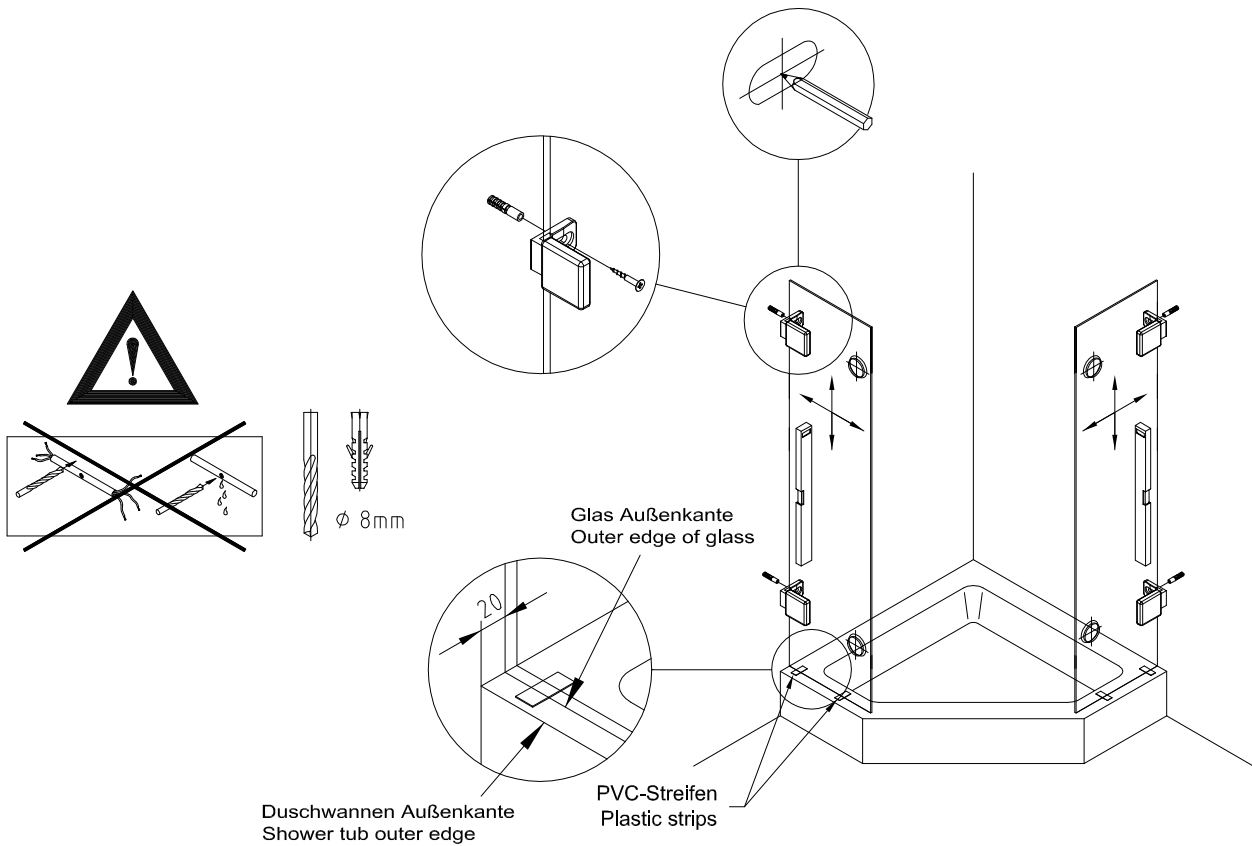

1B

Profilbefestigung / fixed with profile

Klemmprofil ausrichten und Bohrungen anzeichnen.
Löcher bohren und Klemmprofil anschrauben.

Set up clamp profile and mark the drill holes.
Drill holes and fix the clamp profile

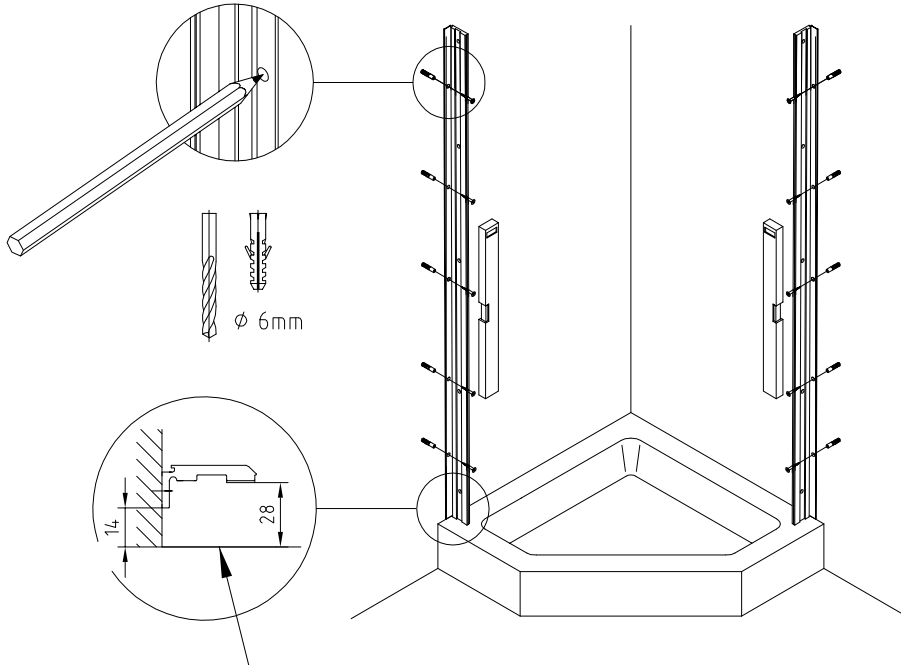

Duschwannen Außenkante
Shower tub outer edge

2B

Seitenteil ausrichten und Klemmstücke anschrauben.

Set up side panel and screw on the clamps.

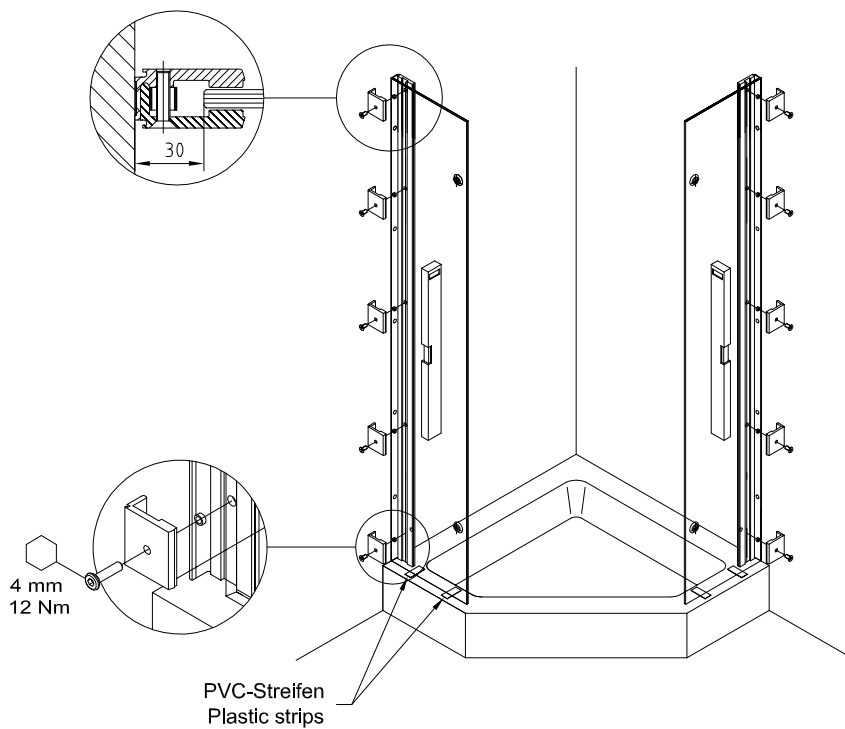

PVC-Streifen
Plastic strips

3

Mitteldichtung auf das Fixteil aufstecken.

Attach the middle seal round onto fixed panel.

Mitteldichtung rund
Middle seal round
Art. 74.157

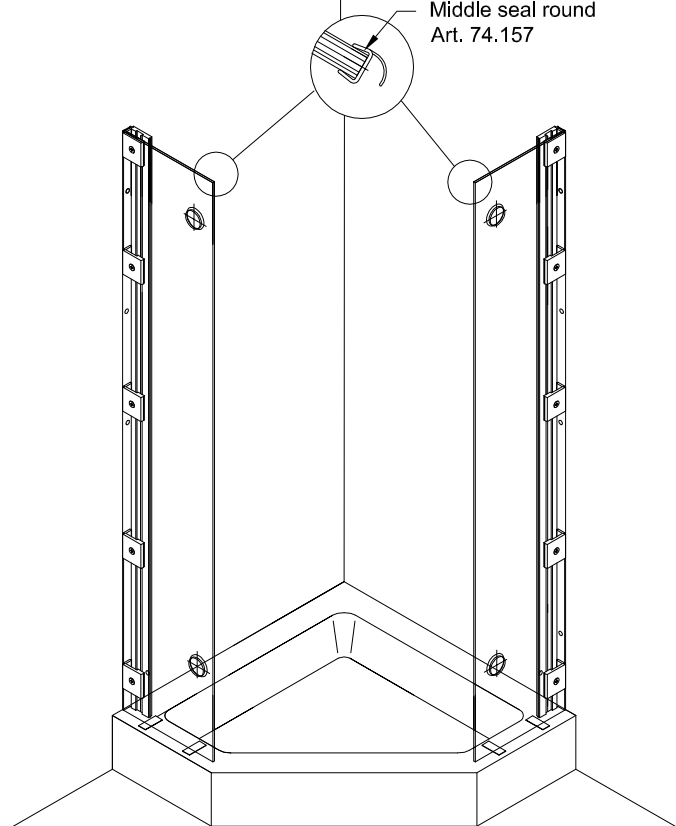

4

Anschlagdichtung vom Beschlag entfernen.
Montagehilfen und Anschlagdichtung auf die Tür aufstecken.

Remove the seal with stop from the hinge.
Attach the assembly blocks and the seal with stop onto door.

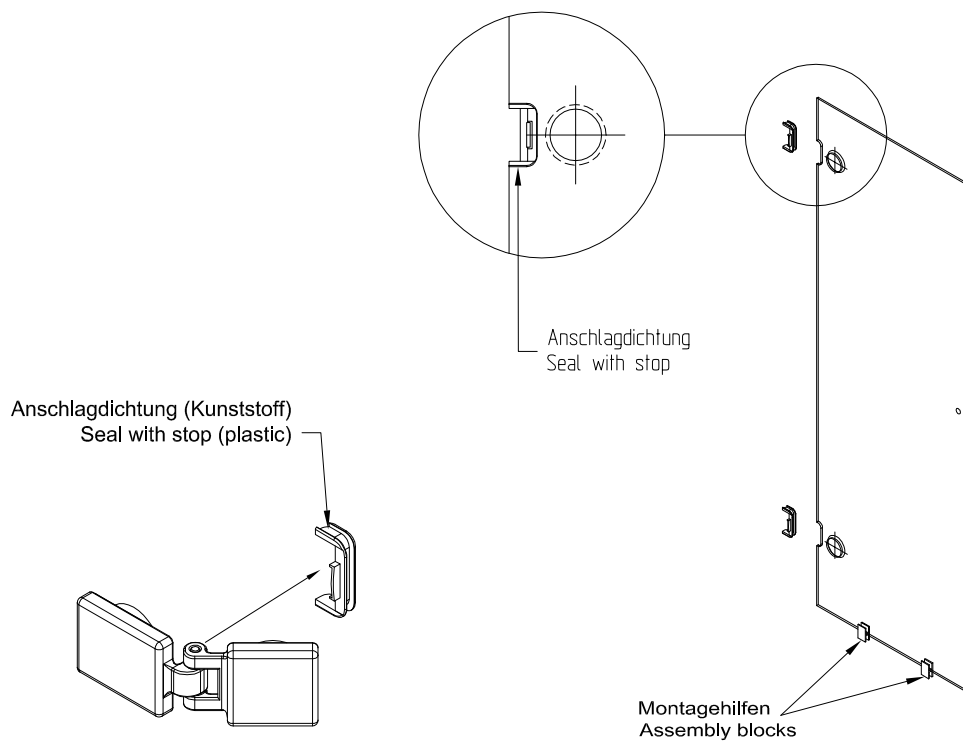

5

Bänder Glas/Glas an die Tür schrauben.
Screw the hinges glass/glass onto the door.

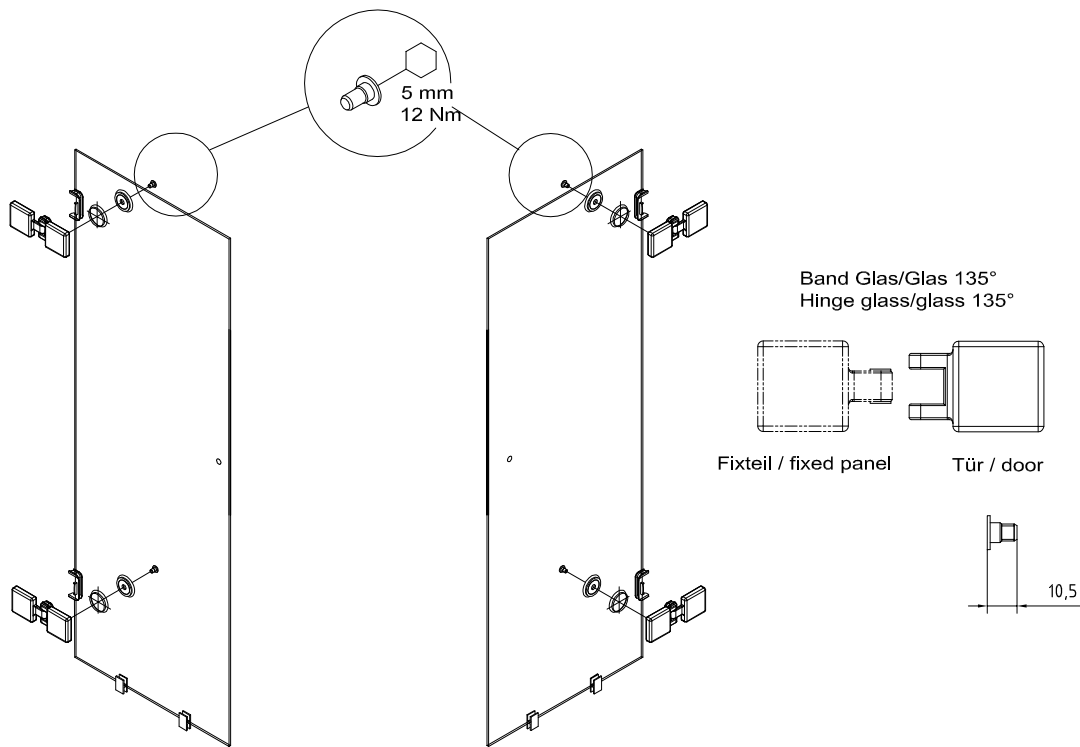

6

Knopf montieren und Magnetdichtung aufstecken.
Screw on the door knob and attach the magnetic seal.

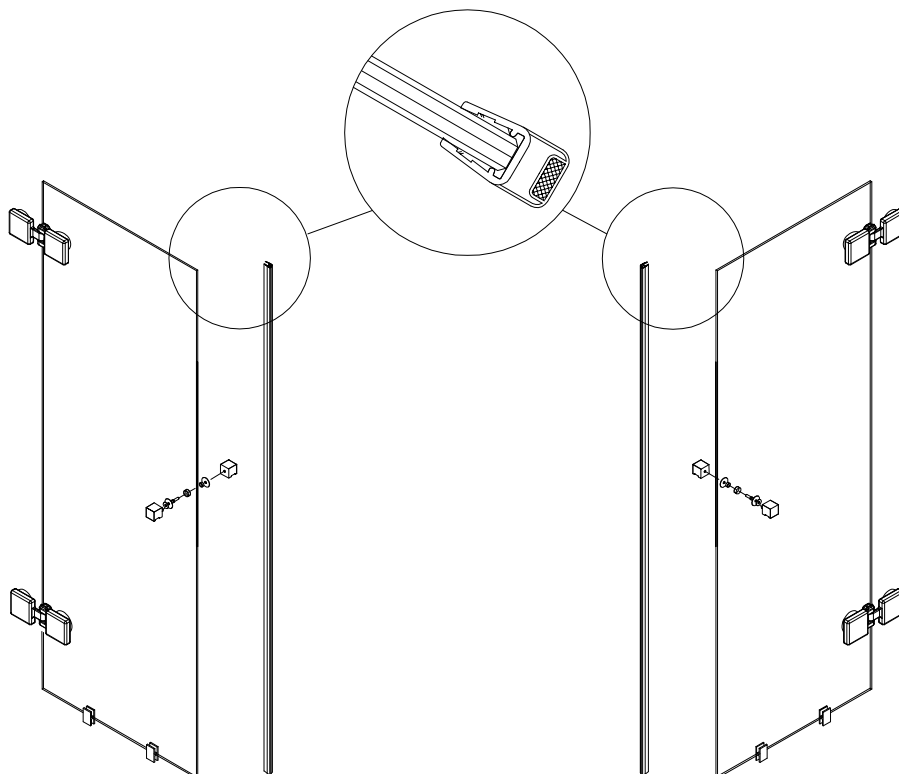

7 Drehtür ausrichten und an das Fixteil montieren.
Adjust the swing door and install onto in-line panel.

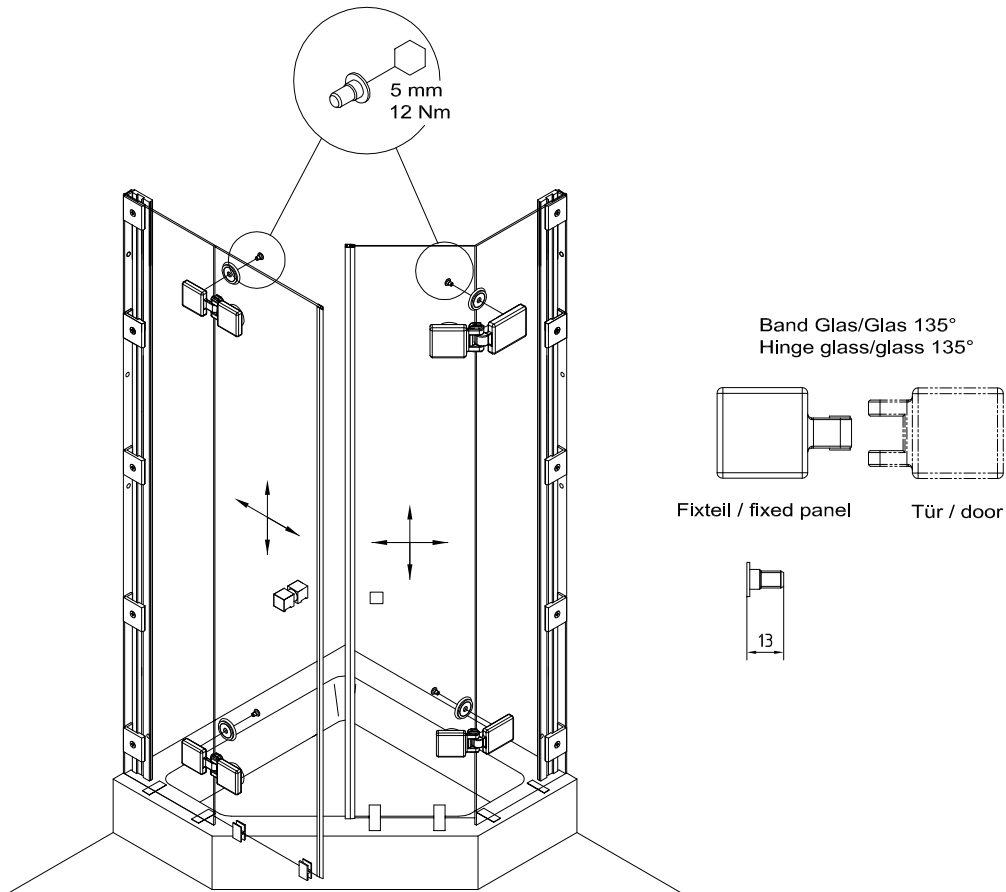

8

1. PVC-Streifen vorsichtig kürzen.
2. Clipsprofile aufstecken.
3. Montagehilfen entfernen.
Wasserabweiser und Mitteldichtung aufstecken.
4. Clipsprofile und Fixteile versiegeln.
5. Montage der Kappen.

1. Shorten plastic strips carefully.
2. Attach the clips profiles.
3. Take of assembly blocks.
Attach water disperser and middle seal.
4. Seal up the clips profiles and the fixed panels.
5. Installation of caps.

Profilbefestigung Fixed with profiles

Winkelbefestigung Fixed with brackets

