

**Montageanleitung
BO 381 / TYP 255
Fünfeckkabine,
1 Drehtür an Fixteil,
1 Seitenteil**

**Assembly instruction
BO 381 / TYPE 255
pentangular cubicle,
1 swing door fixed to
in-line panel, 1 side panel**

Wichtige Informationen:
Important information:

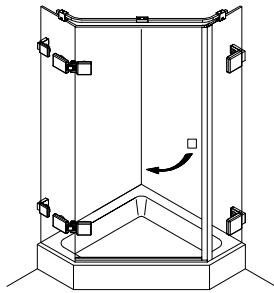

mit Winkelbefestigung
 fixed with brackets

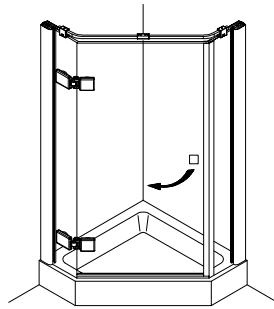

mit Profilbefestigung
 fixed with profiles

Vor der Montage Glasflächen
 mit handelsüblichem Glasreiniger
 im Bereich der Klemmflächen reinigen.

All glass clamping areas are to
 be cleaned with standard glass
 cleaning products prior to installation.



keine Verdünnung verwenden
 Do not use thinners

Wichtiger Hinweis

Glas beim Auspacken immer mit Schutz (Pappe oder Ähnlichem) auf den Fußboden stellen.
 Kanten und Ecken des Glases nicht anstoßen lassen.
 Konstruktionsbedingt ist bei rahmenlosen Duschabtrennungen keine absolute Abdichtung erreichbar.
 Die Montage der jeweils beiliegenden Dichtlippen gewährleistet die maximal erreichbare Dichtigkeit.
 Alle Maßangaben in mm!

Important notice!

While unpacking the glass always use the protection of the wood or cardboard, as available and
 set it on the floor. Be careful not to bump into anything with the trim and edges of the glass.
 Because of the construction of the frameless shower enclosure a complete seal cannot be obtained.
 The installation of the enclosed seals provide the maximal obtainable sealant.
 All measurements are in mm.

Montagewerkzeug:
Assembly tools:

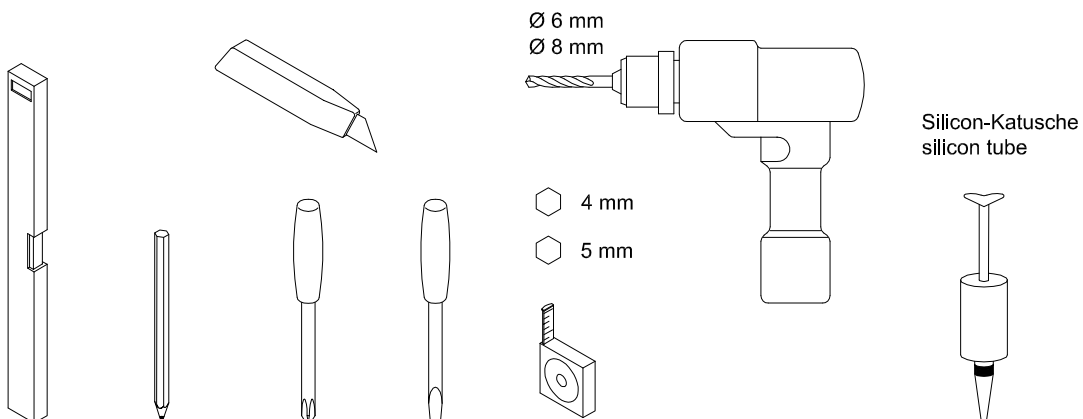

Lieferumfang:
Scope of delivery:

DIN links wie gezeichnet / DIN rechts spiegelbildlich
 DIN left shown / DIN right in mirror image

mit Profilbefestigung:
fixed with profile:

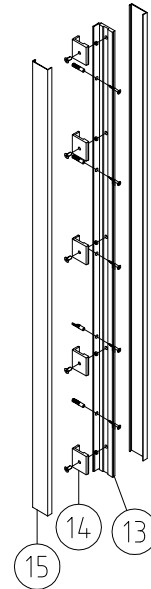
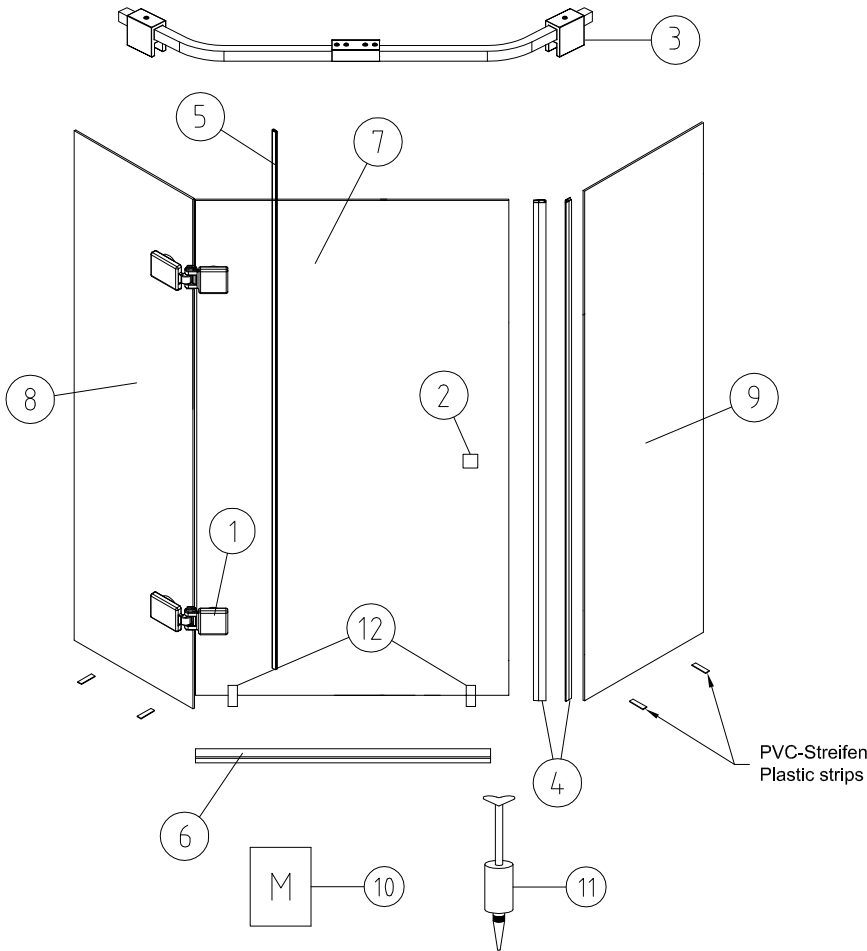

mit Winkelbefestigung:
fixed with brackets:

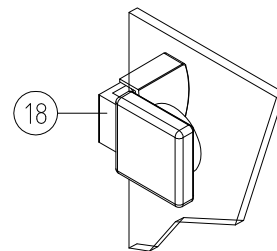

Material

① Band G/G 135° / glass/glass hinge 135°	2
② Türkнопf / door knob	1
③ Haltestange / universal support bar	1
④ Magnetdichtung 135° / magnetic seal 135°	1
⑤ Mitteldichtung rund / soft nose seal round	1
⑥ Wasserabweiser biegsam / water disperser flexible	1
⑦ Glas Drehtür (optional) / glass swing door (optional)	1
⑧ Glas Fixteil (optional) / glass in-line panel (optional)	1
⑨ Glas Seitenteil (optional) / glass side panel (optional)	1
⑩ Montageanleitung / installation instruction	1
⑪ Silikon-Katusche / silicon tube	1
⑫ Montage Hilfe / assembly blocks	2

Profilbefestigung / fixed with profile

⑬ Klemmprofil / clamp profile	2
⑭ Klemmstücke / clamps	10
⑮ Clipsprofil / clips profile	4

oder / or

Winkelbefestigung / fixed with brackets

⑯ Winkel G/W / glass/wall bracket	4
-----------------------------------	---

Einbausituation Profilbefestigung:
Mounting arrangement fixed with profile:

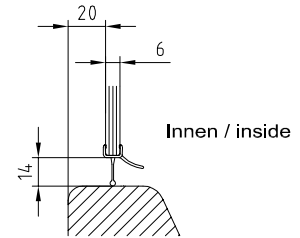
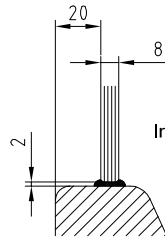
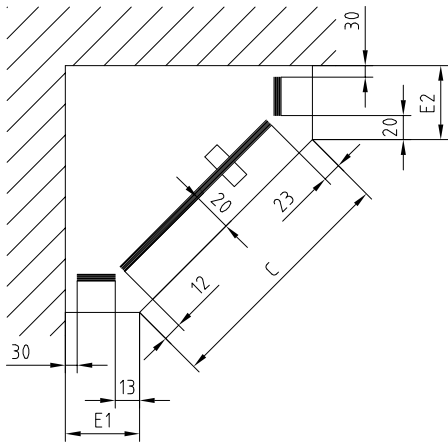

Einbausituation Winkelbefestigung:
Mounting arrangement fixed with bracket:

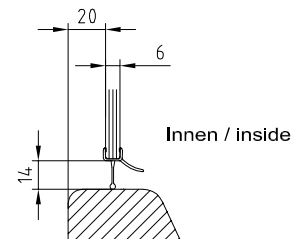
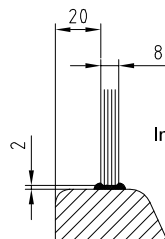
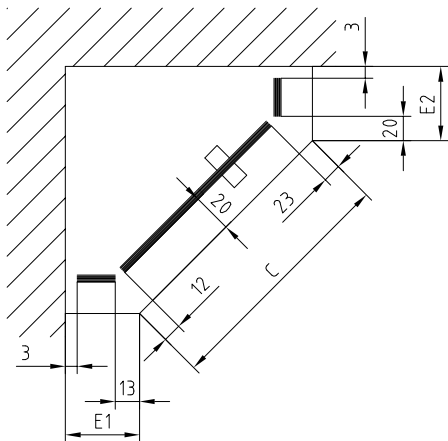

1A

Winkelbefestigung / fixed with brackets

Winkel Glas/Wand an das Glas schrauben.

Screw the brackets glass/wall onto the glass.

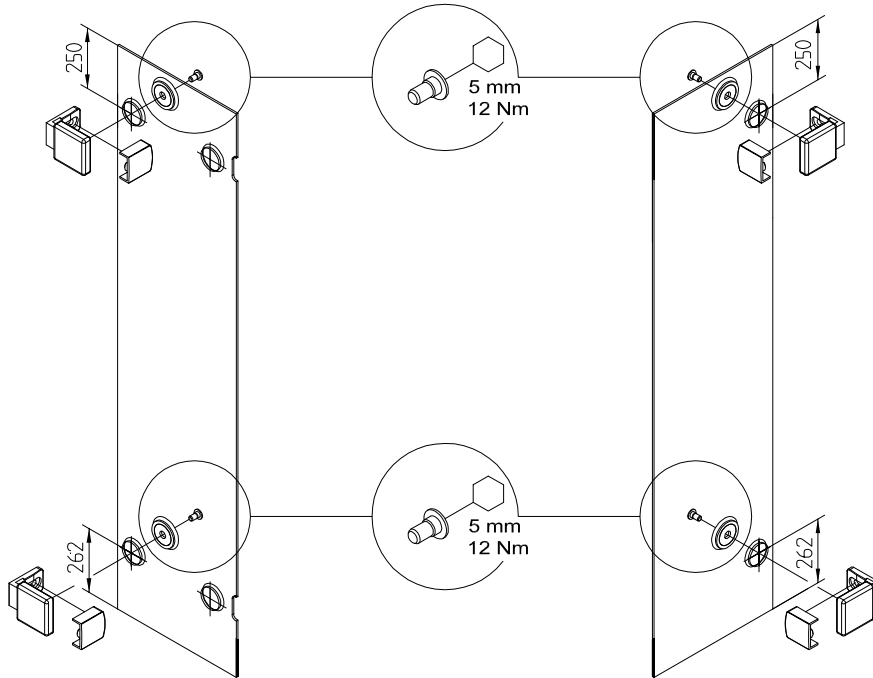

2A

PVC-Streifen unterlegen.

Flxteil und Seitenteil ausrichten, anzeichnen, bohren und verschrauben.

Place the plastic strips under the glass.

Adjust the in-line and side panel, mark, drill and screw on.

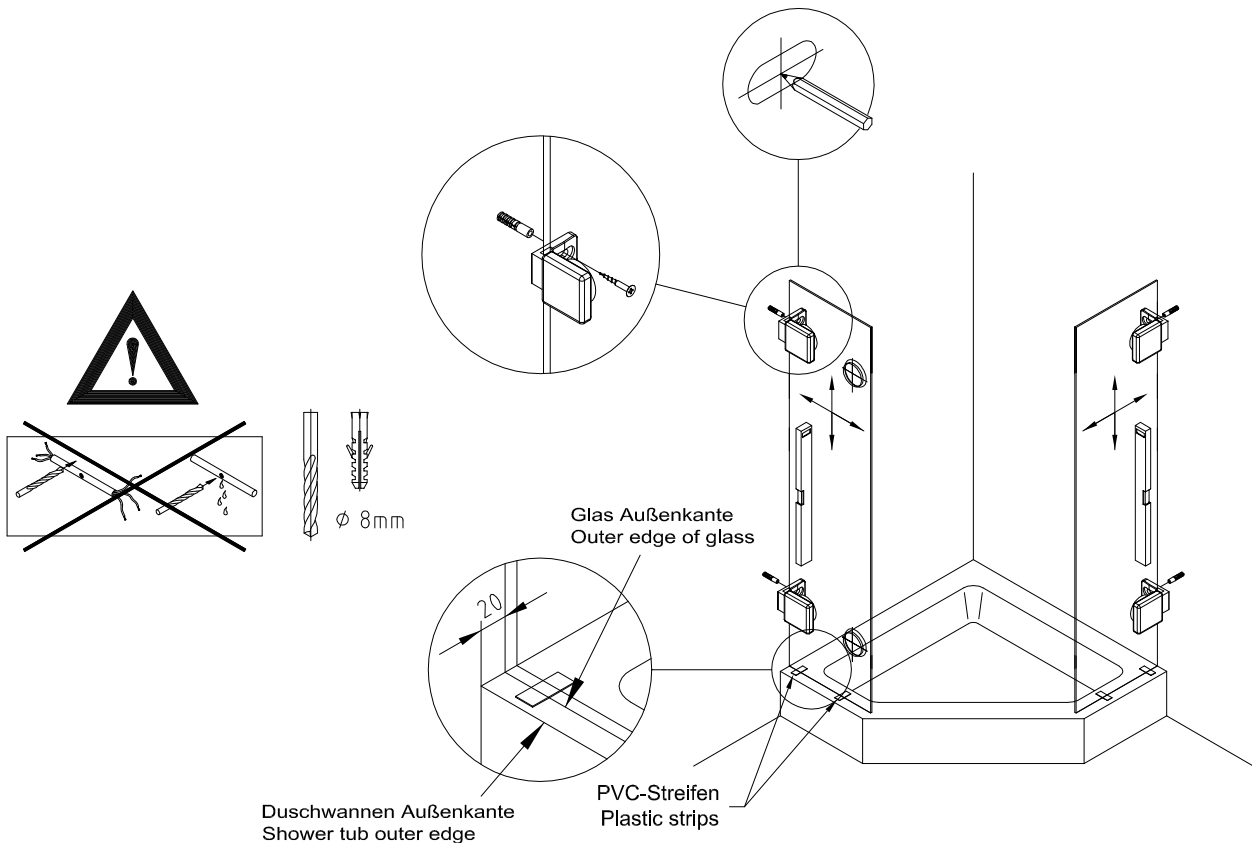

1B Profilbefestigung / fixed with profile

Klemmprofile ausrichten und Bohrungen anzeichnen.
Löcher bohren und Klemmprofile anschrauben.

Set up clamp profiles and mark the drill holes.
Drill holes and fix the clamp profiles.

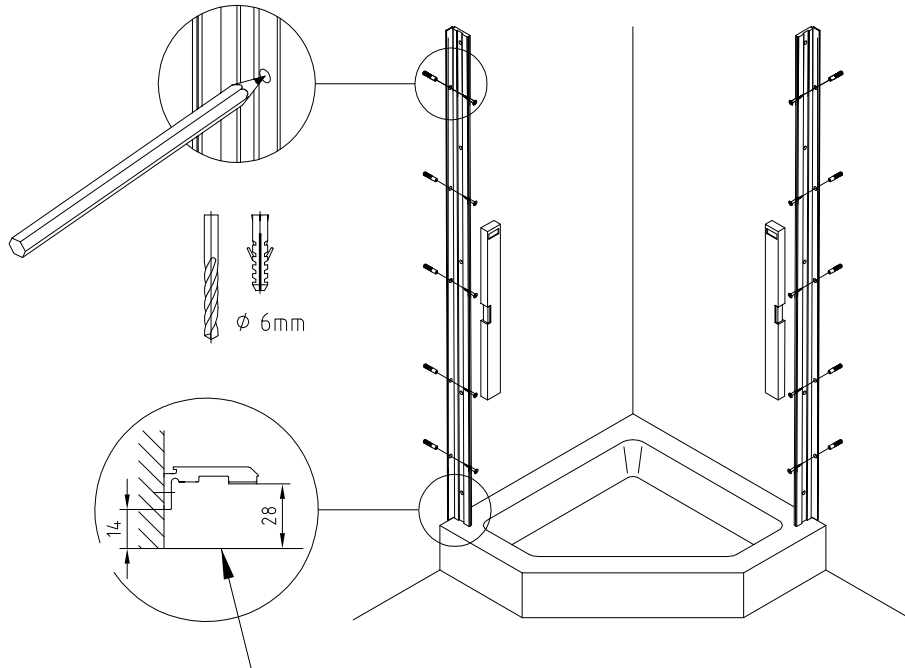

Duschwannen Außenkante
Shower tub outer edge

2B Fixteil und Seitenteil ausrichten und Klemmstücke anschrauben.

Set up in-line and side panel and screw on the clamps.

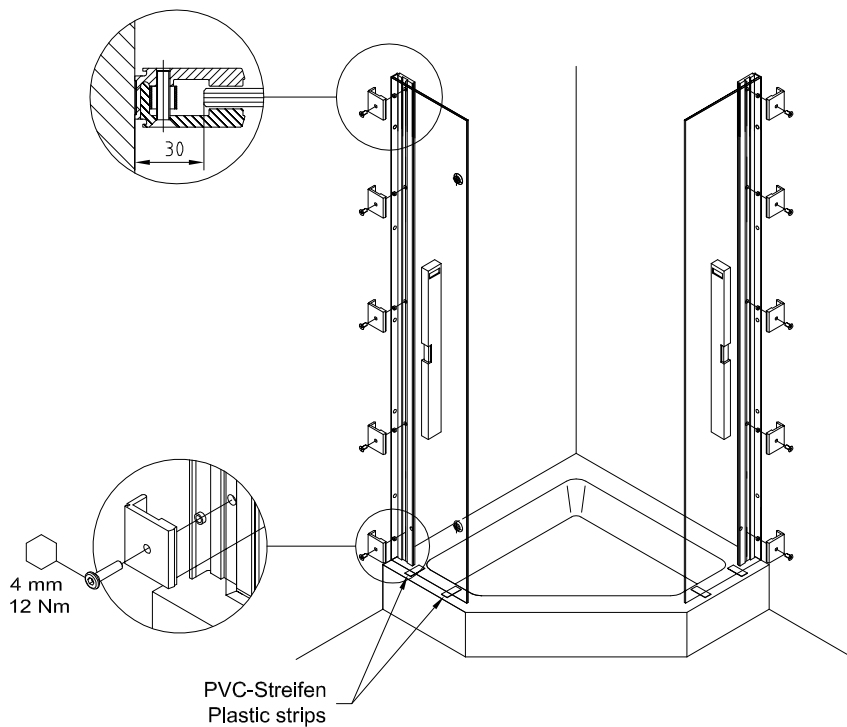

PVC-Streifen
Plastic strips

3

Mitteldichtung auf das Fixteil aufstecken.

Attach the middle seal round onto fixed part.

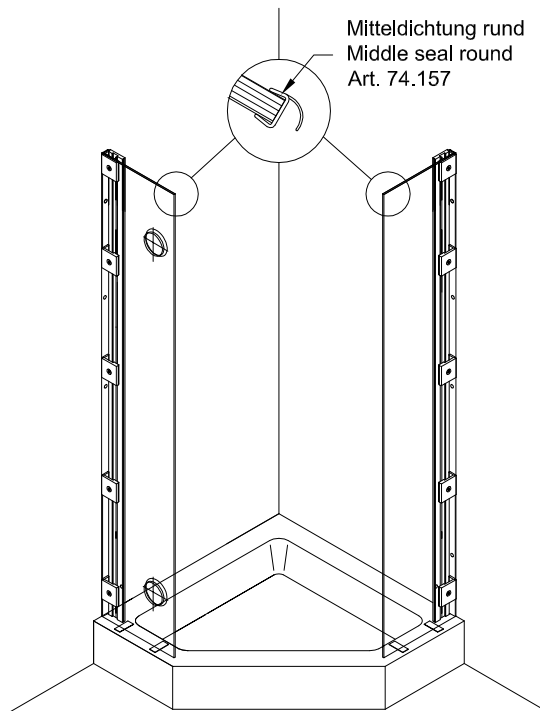

4

Anschlagdichtung vom Beschlag entfernen.

Montagehilfen und Anschlagdichtung auf die Tür aufstecken.

Remove the seal with stop from the hinge.

Attach the assembly blocks and the seal with stop onto door.

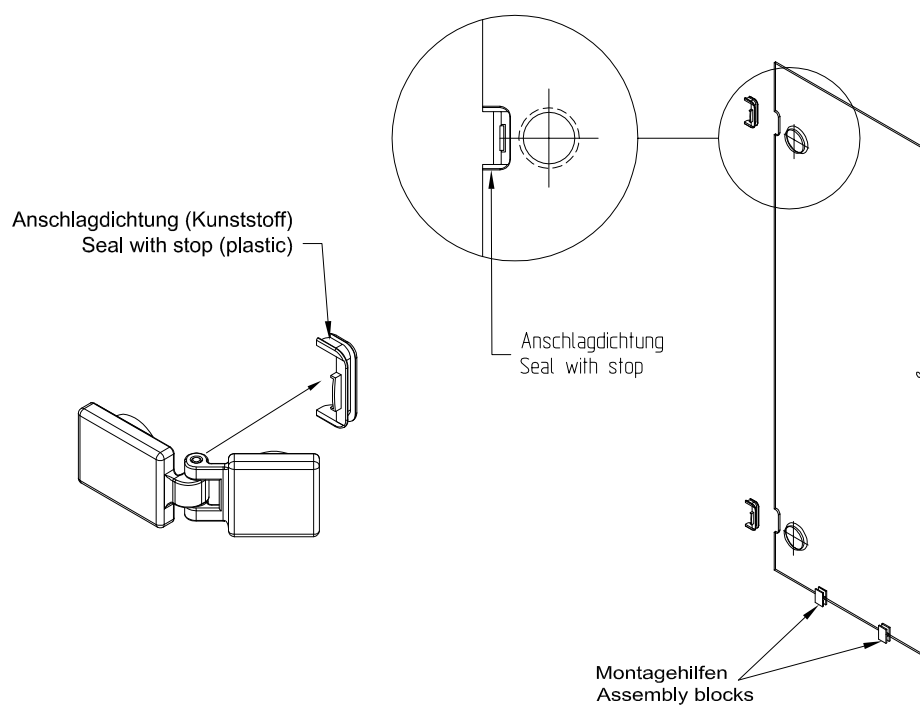

5

Bänder Glas/Glas an die Tür schrauben.
Screw on hinges glass/glass onto the door.

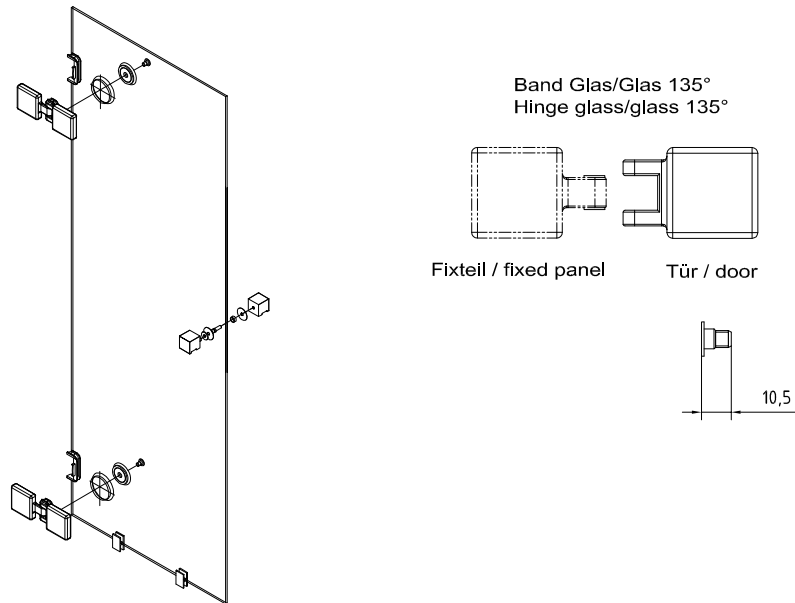

6

Knopf montieren und Magnetdichtung aufstecken.
Screw on the door knob and attach the magnetic seal.

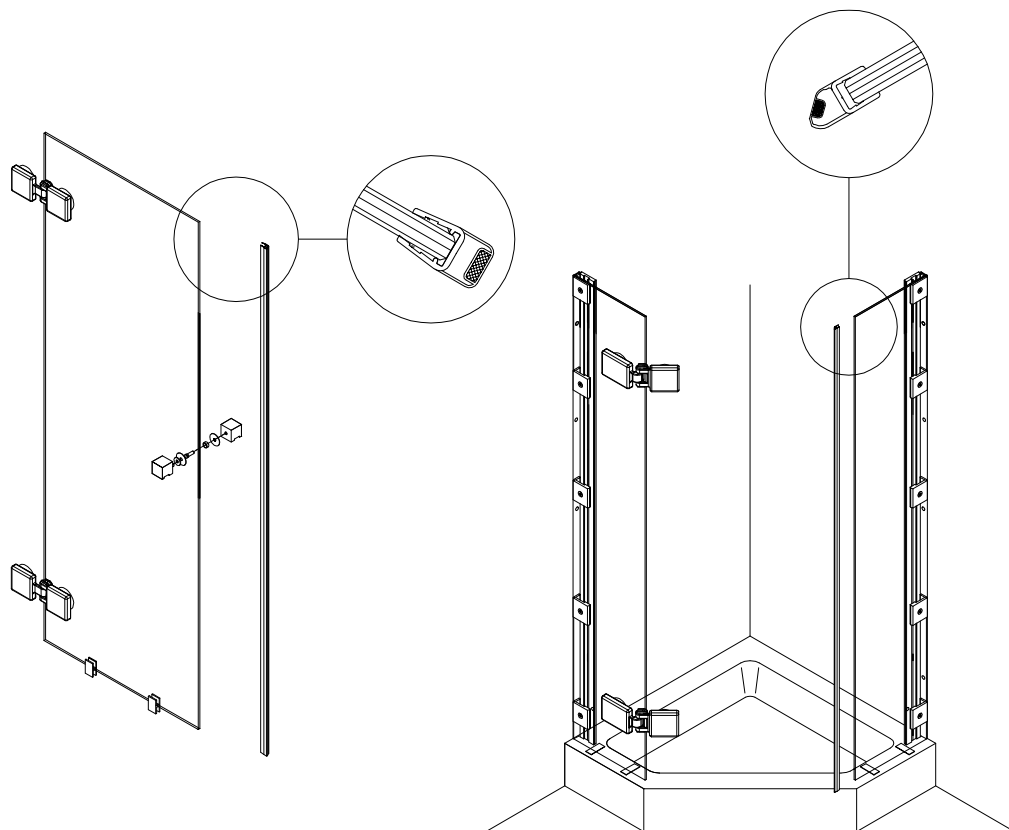

7

Drehtür ausrichten und an das Fixteil montieren.
Adjust the swing door and install onto in-line panel.

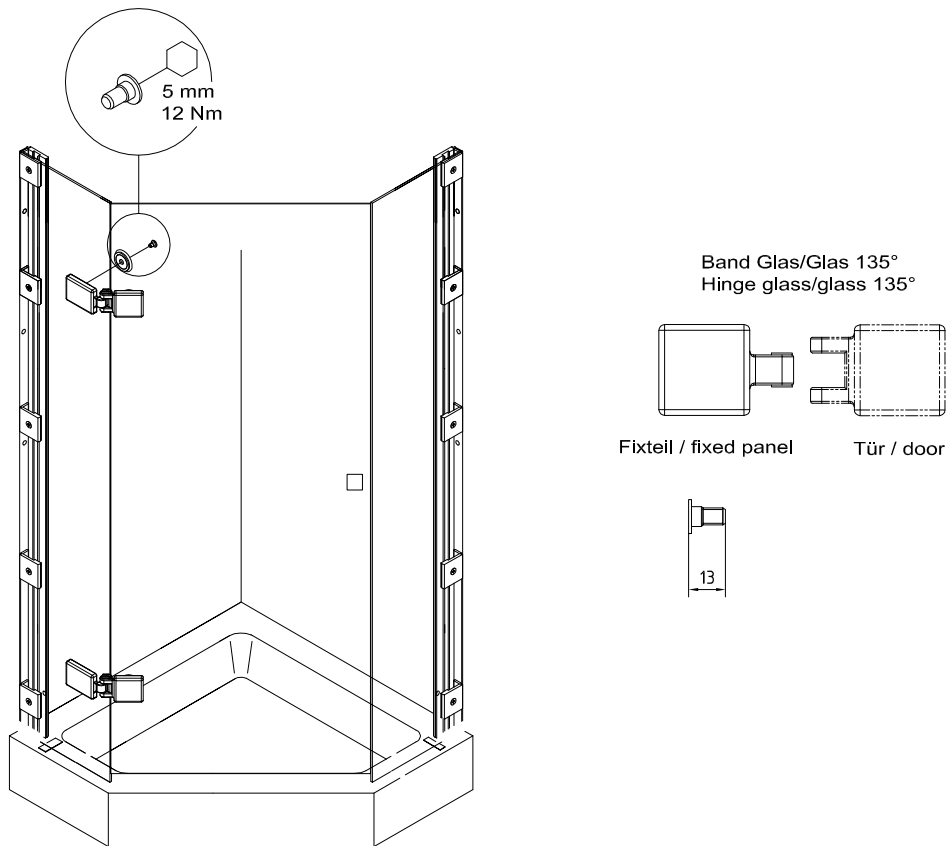

8

Montage der Haltestange.
Installation of universal support bar.

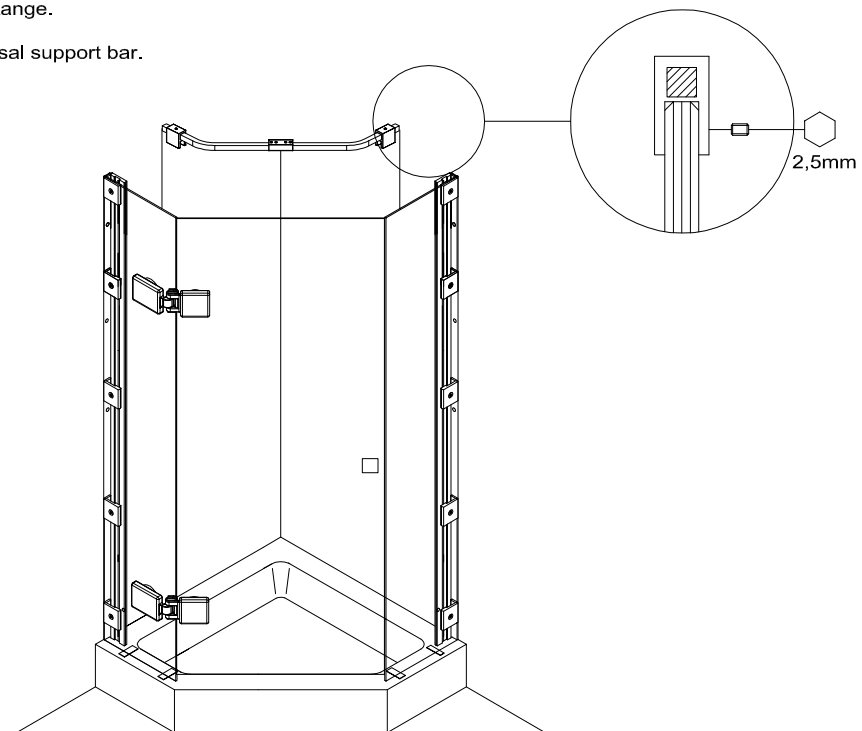

9

1. PVC-Streifen vorsichtig kürzen.
2. Clipsprofile aufstecken.
3. Montagehilfen entfernen.
Wasserabweser und Mitteldichtung aufstecken.
4. Clipsprofile und Fixteile versiegeln.
5. Montage der Kappen.

1. Shorten plastic strips carefully.
2. Attach the clips profiles.
3. Take of assembly blocks.
Attach water disperser and middle seal.
4. Seal up the clips profiles and the fixed panels.
5. Installation of caps.



Montage der Haltestange, siehe Montageanleitung 800.52.390.6.32
Installation of support bar, see installation instruction 800.52.390.6.32

Profilbefestigung
Fixed with profiles

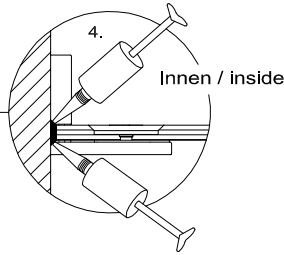
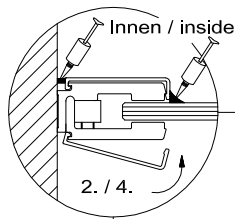

Winkelbefestigung
Fixed with brackets

