

**Montageanleitung
BO 381 / TYP 260
Viertelkreiskabine,
2 gebogene Drehtüren an
Fixteilen, mit Winkel-/
Profilbefestigung**

**Assembly instruction
BO 381 / TYPE 260
Curved shower enclosure with
two curved glass swing doors
fixed to in-line panels,
fixed with brackets/profiles**

Wichtige Informationen:
Important information:

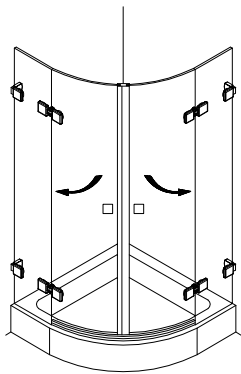

mit Winkelbefestigung
 fixed with brackets

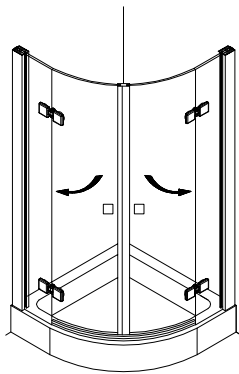

mit Profildbefestigung
 fixed with profiles

Vor der Montage Glasflächen mit handelsüblichem Glasreiniger im Bereich der Klemmflächen reinigen.

All glass clamping areas are to be cleaned with standard glass cleaning products prior to installation.



keine Verdünnung verwenden
 Do not use thinners

Wichtiger Hinweis

Glas beim Auspacken immer mit Schutz (Pappe oder Ähnlichem) auf den Fußboden stellen. Kanten und Ecken des Glases nicht anstoßen lassen. Konstruktionsbedingt ist bei rahmenlosen Duschatbrennungen keine absolute Abdichtung erreichbar. Die Montage der jeweils beiliegenden Dichtlippen gewährleistet die maximal erreichbare Dichtigkeit. Alle Maßangaben in mm!

Important notice!

While unpacking the glass always use the protection of the wood or cardboard, as available and set it on the floor. Be careful not to bump into anything with the trim and edges of the glass. Because of the construction of the frameless shower enclosure a complete seal cannot be obtained. The installation of the enclosed seals provide the maximal obtainable sealant. All measurements are in mm.

Montagewerkzeug:
Assembly tools:

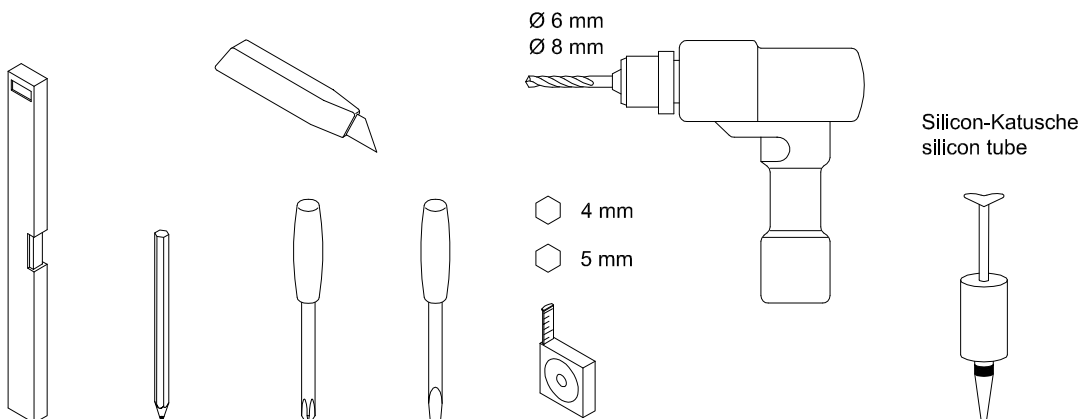

**Lieferumfang:
Scope of delivery:**

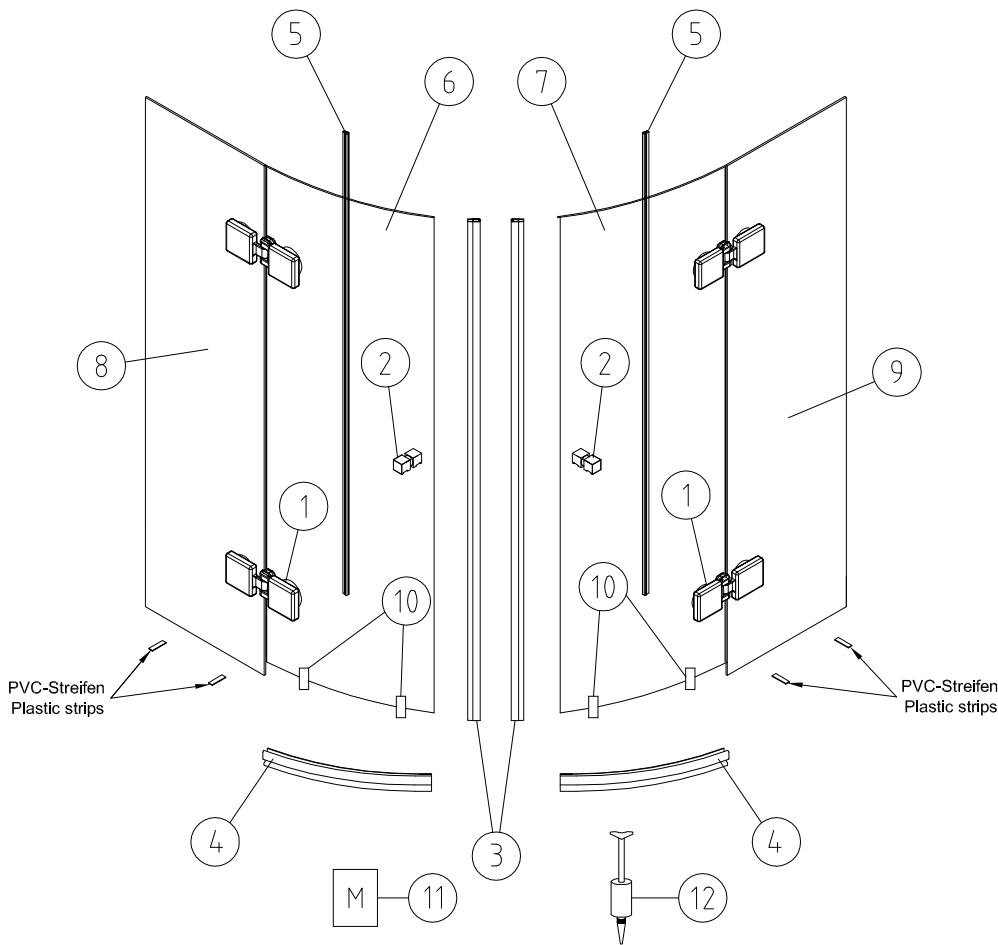

**mit Profilbefestigung:
fixed with profile:**

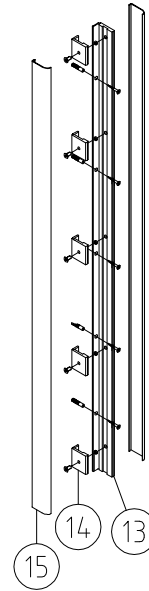

**mit Winkelbefestigung:
fixed with brackets:**

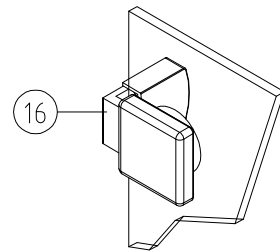

Material

① Band G/G 180° / glass/glass hinge 180°	4
② Türkнопf / door knob	2
③ Magnetsichtung 180° / magnetic seal 180°	1
④ Wasserabweiser biegsam / water disperser flexible	2
⑤ Schlauchdichtung / soft nose seal	2
⑥ Glas Drehtür links (optional) / glass swing door LH (optional)	1
⑦ Glas Drehtür rechts (optional) / glass swing door RH (optional)	1
⑧ Glas Fixteil links (optional) / glass fixed panel LH (optional)	1
⑨ Glas Fixteil rechts (optional) / glass fixed panel RH (optional)	1
⑩ Montage Hilfe / assembly blocks	4
⑪ Montageanleitung / assembly instruction	1
⑫ Silikon Katusche / silicon tube	1

Profilbefestigung / fixed with profile

⑫ Klemmprofil / clamp profile	2
⑬ Klemmstücke / clamps	10
⑭ Clipsprofil / clips profile	4

oder / or

Winkelbefestigung / fixed with brackets

⑯ Winkel G/W / glass/wall bracket	4
-----------------------------------	---

Einbausituation Profilbefestigung:
Mounting arrangement fixed with profile:

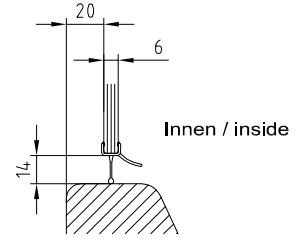
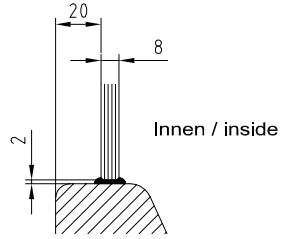
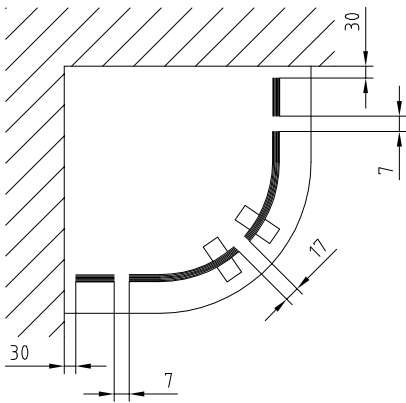

Einbausituation Winkelbefestigung:
Mounting arrangement fixed with bracket:

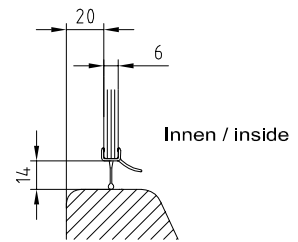
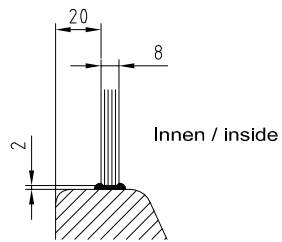
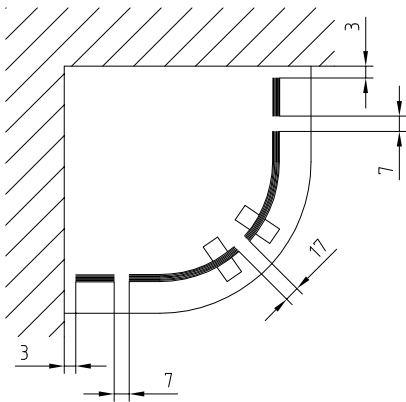

1A

Winkelbefestigung / fixed with brackets

Winkel Glas/Wand an Fixteile schrauben.

Screw the brackets glass/wall onto in-line panels.

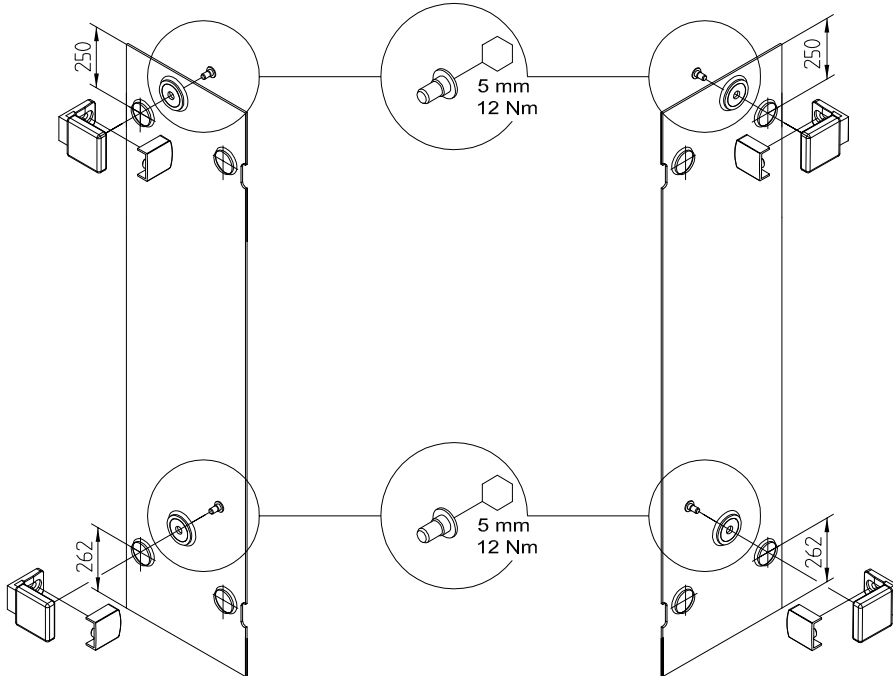

2A

PVC-Streifen unterlegen.

Fixteile ausrichten, anzeichnen, bohren und verschrauben.

Place the plastic strips under the glass.

Adjust in-line panels, mark, drill and screw on.

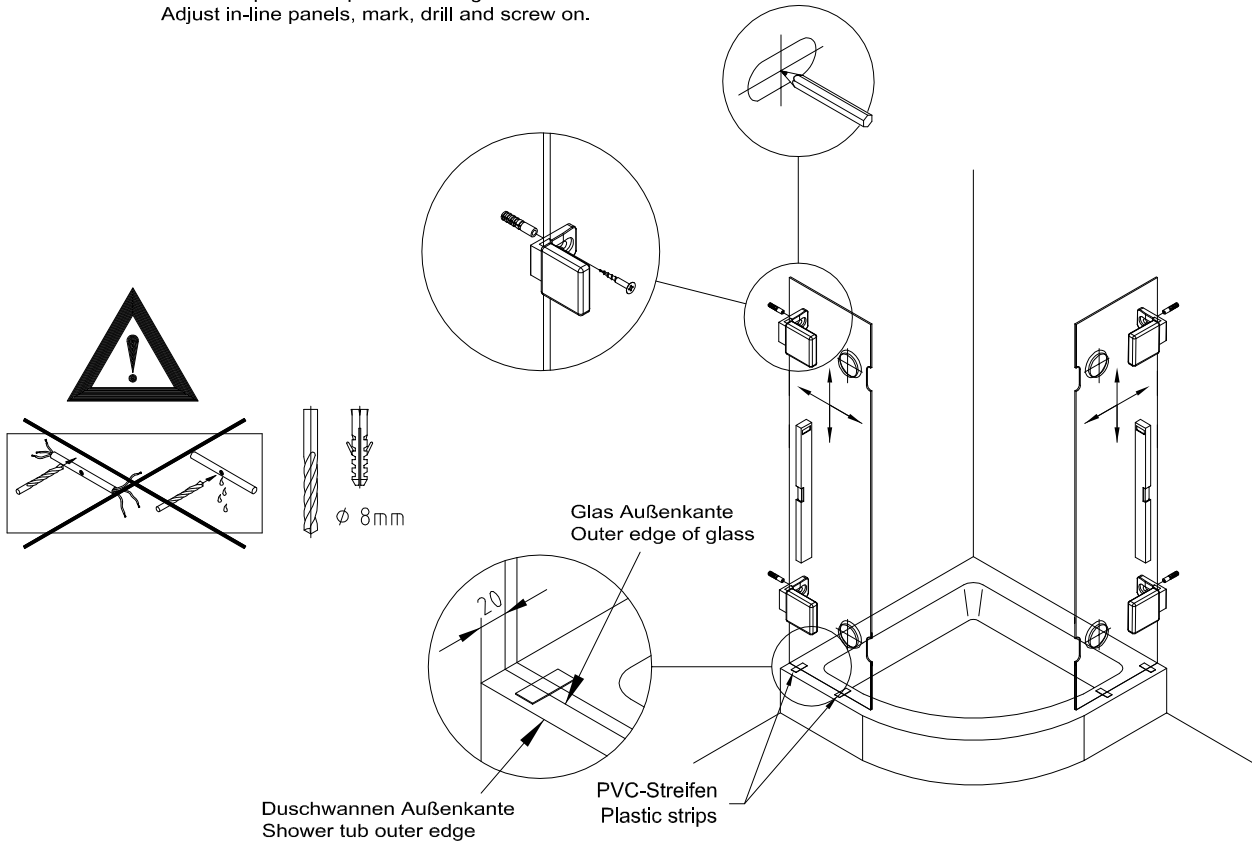

1B Profilbefestigung / fixed with profile

Klemmprofil ausrichten und Bohrungen anzeichnen.
Löcher bohren und Klemmprofil anschrauben.

Set up clamp profile and mark the drill holes.
Drill holes and fix the clamp profile

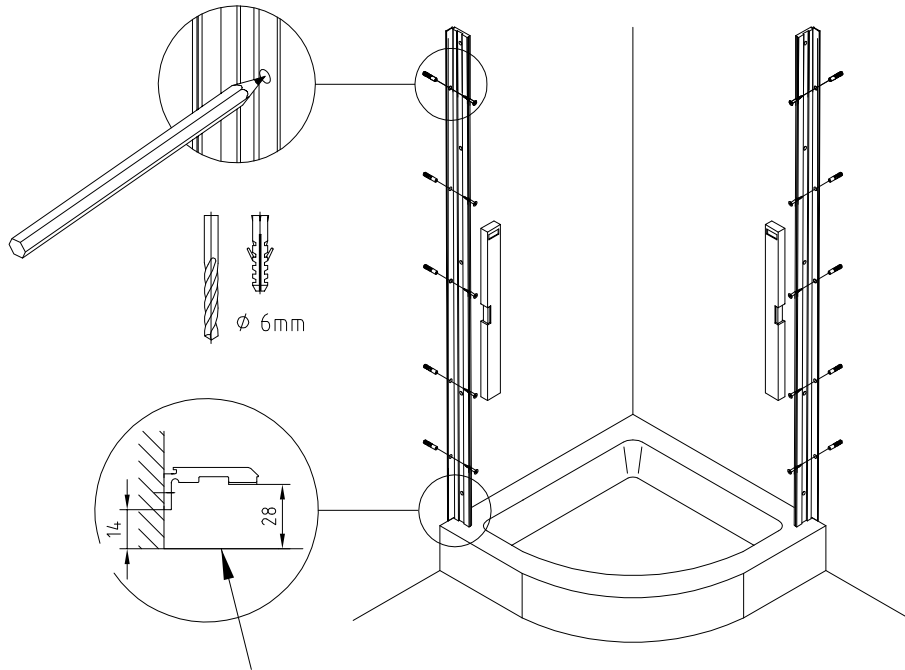

Duschwannen Außenkante
Shower tub outer edge

2B Seitenteil ausrichten und Klemmstücke anschrauben.

Set up side panel and screw on the clamps.

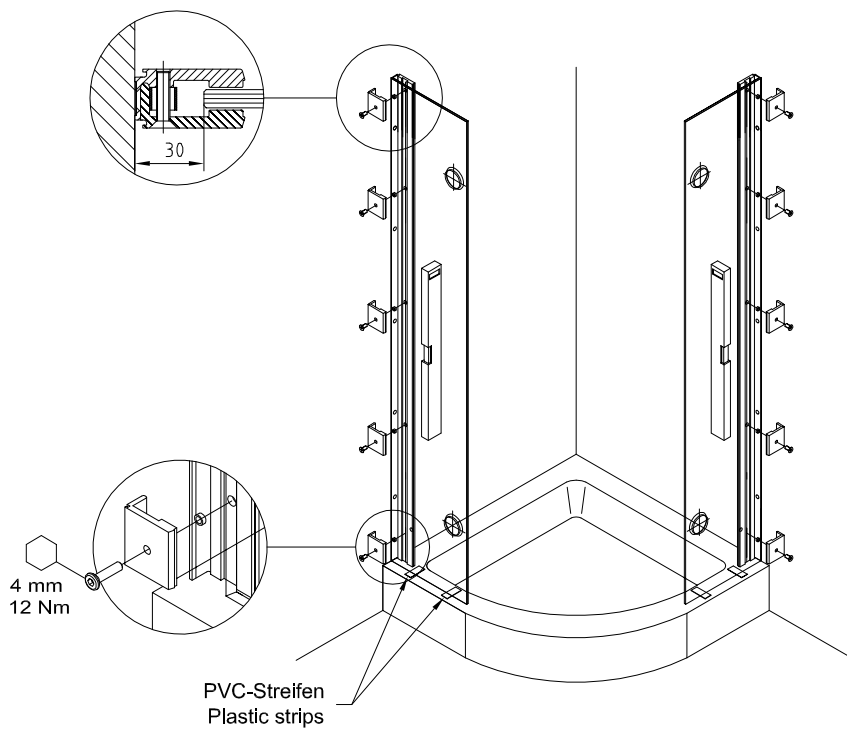

4 mm
12 Nm

PVC-Streifen
Plastic strips

3

Schlauchdichtung auf das Fixteil aufstecken.

Attach the soft nose seal onto fixed panel.

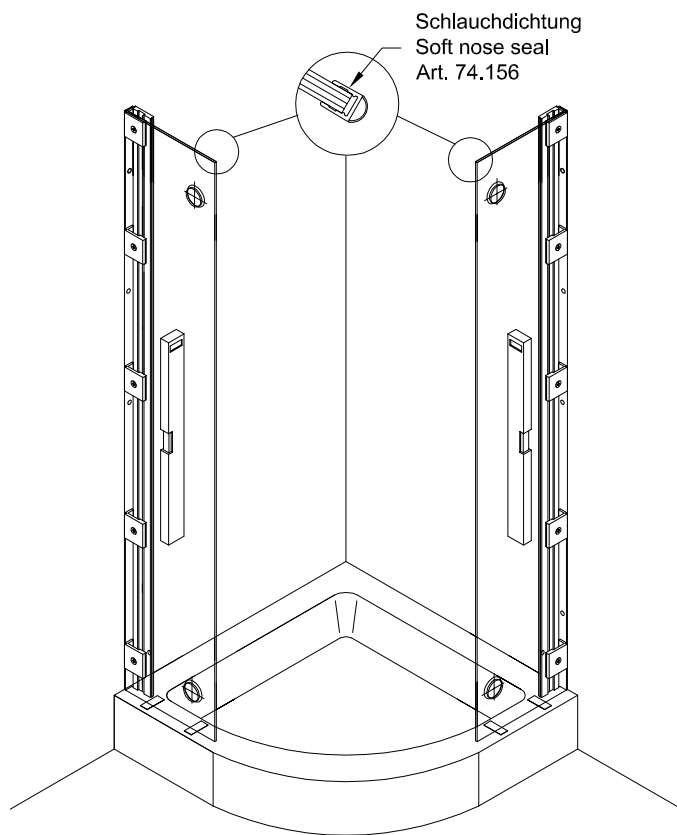

4

Anschlagdichtung vom Beschlag entfernen.
Montagehilfen und Anschlagdichtung auf die Tür aufstecken.

Remove the seal with stop from the hinge.
Attach the assembly blocks and the seal with stop onto door.

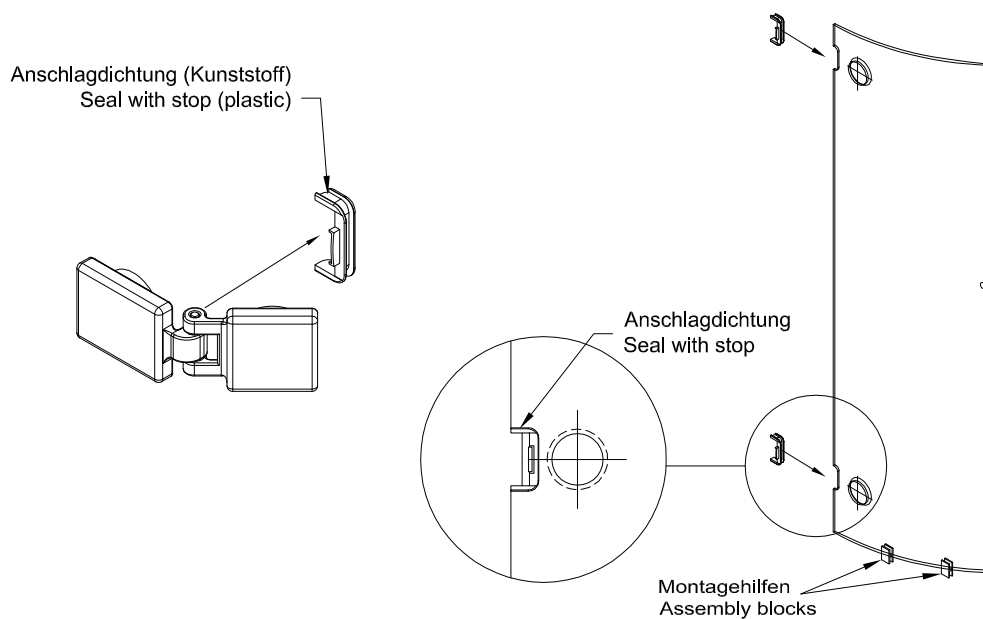

5

Bänder Glas/Glas an die Tür schrauben.

Screw on the hinges glass/glass onto the door.

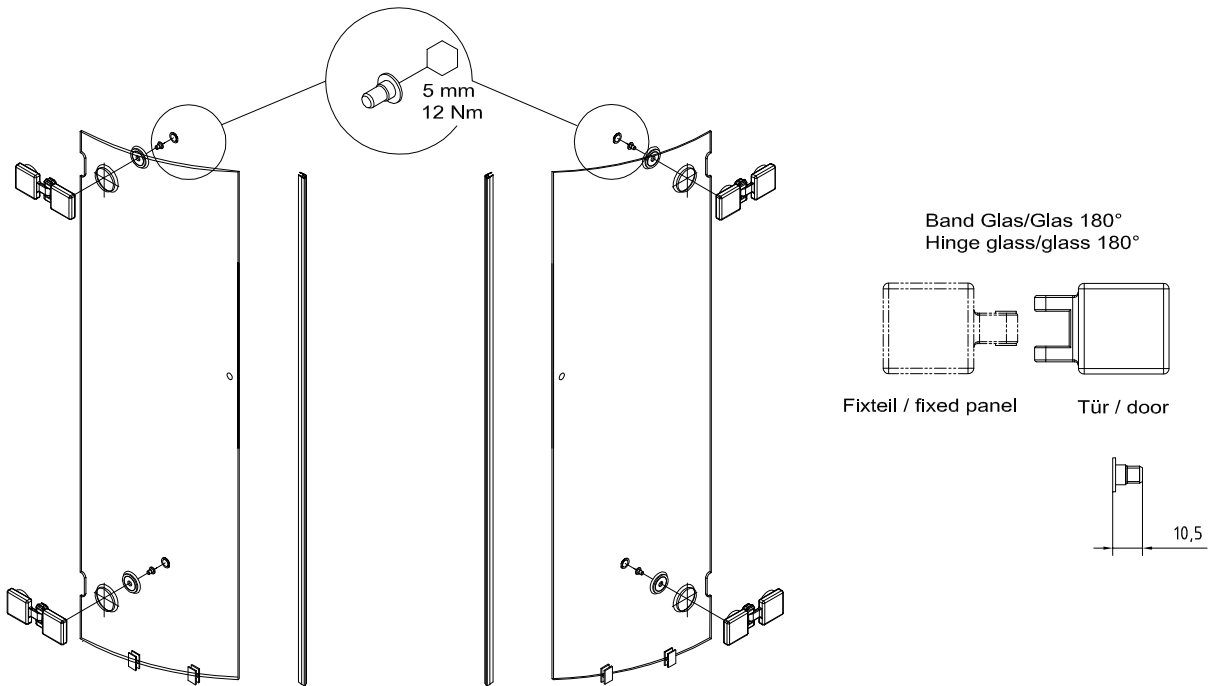

6

Knopf montieren und Magnetdichtung aufstecken.

Screw on the door knob and attach the magnetic seal.

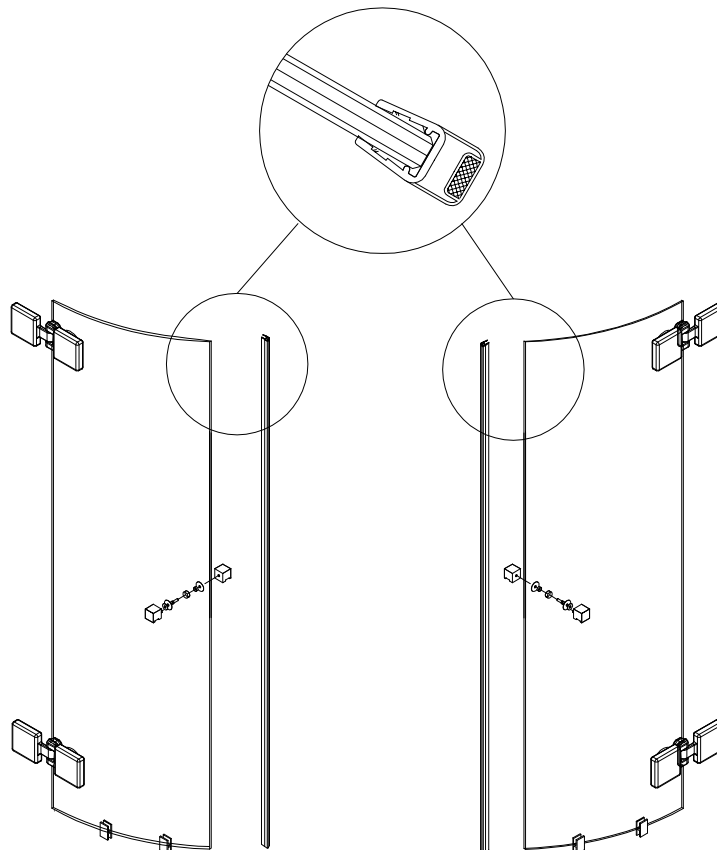

7

Drehtür ausrichten und an das Fixteil montieren.
Adjust the swing door and install onto in-line panel.

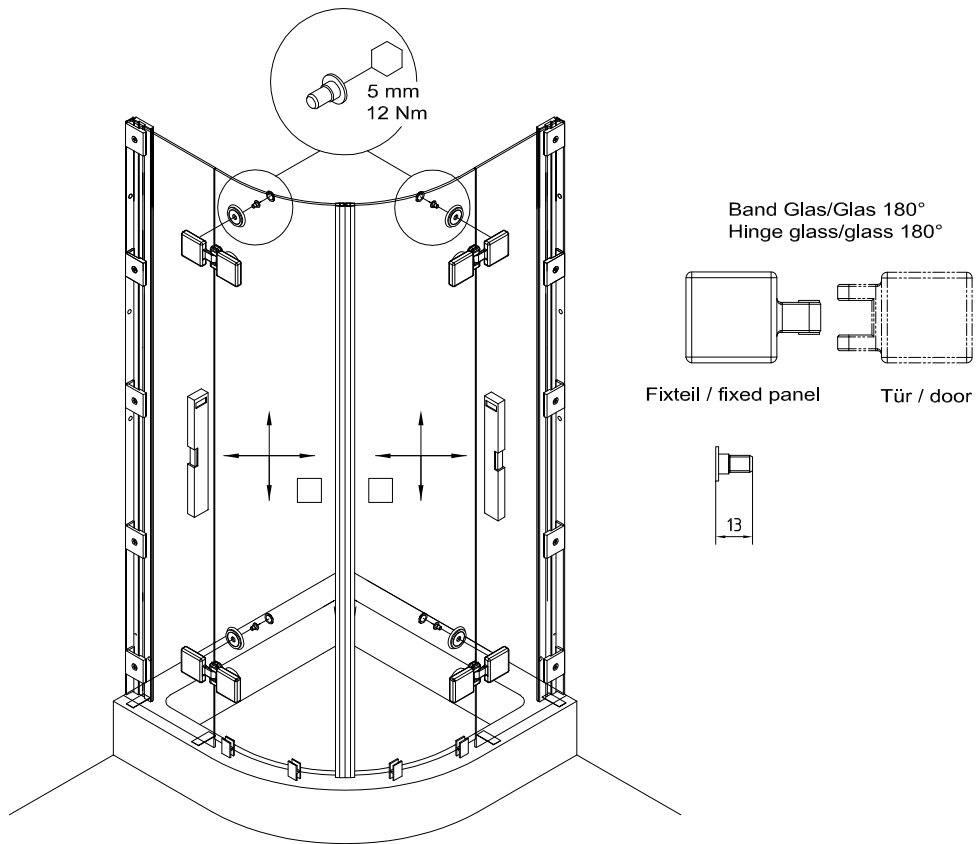

8

1. PVC-Streifen vorsichtig kürzen.
2. Clipsprofile aufstecken.
3. Montagehilfen entfernen.
Wasserabweser und Mitteldichtung aufstecken.
4. Clipsprofile und Fixteile versiegeln.
5. Montage der Kappen.

1. Shorten plastic strips carefully.
2. Attach the clips profiles.
3. Take of assembly blocks.
Attach water disperser and middle seal.
4. Seal up the clips profiles and the fixed panels.
5. Installation of caps.

Profilbefestigung
Fixed with profiles

Winkelbefestigung
Fixed with brackets

