

**Montageanleitung  
BH 2401 / TYP 200  
Nischenkabine  
1 Drehtür am Fixteil,  
mit Winkel- /  
Profilbefestigung**

**Assembly instruction  
BH 2401 / TYPE 200  
niche cubicle  
1 swing door fixed to  
in-line panel,  
fixed with bracket  
or profile**

**Wichtige Informationen:**  
**Important information:**

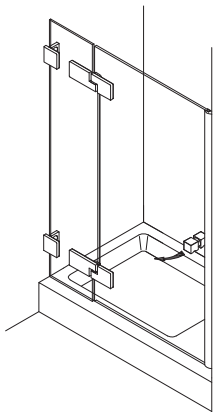

mit Winkelbefestigung  
fixed with brackets

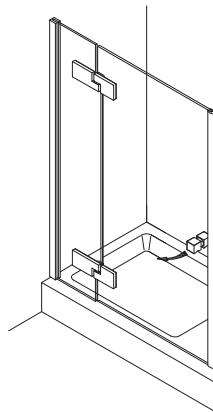

mit Profilbefestigung  
fixed with profiles

Vor der Montage Glasflächen  
mit handelsüblichem Glasreiniger  
im Bereich der Klemmflächen reinigen.

All glass clamping areas are to  
be cleaned with standard glass  
cleaning products prior to installation.



keine Verdünnung verwenden  
Do not use thinners

**Wichtiger Hinweis**

Glas beim Auspacken immer mit Schutz (Pappe oder Ähnlichem) auf den Fußboden stellen.  
Kanten und Ecken des Glases nicht anstoßen lassen.

Konstruktionsbedingt ist bei rahmenlosen Duschtrennungen keine absolute Abdichtung erreichbar.  
Die Montage der jeweils beiliegenden Dichtlippen gewährleistet die maximal erreichbare Dichtigkeit.  
Alle Maßangaben in mm!

**Important notice!**

While unpacking the glass always use the protection of the wood or cardboard, as available and set it on the floor. Be careful not to bump into anything with the trim and edges of the glass.  
Because of the construction of the frameless shower enclosure a complete seal cannot be obtained.  
The installation of the enclosed seals, provide the maximal obtainable sealant.  
All measurements are in mm.

**Montagewerkzeug:**  
**Mounting tool:**

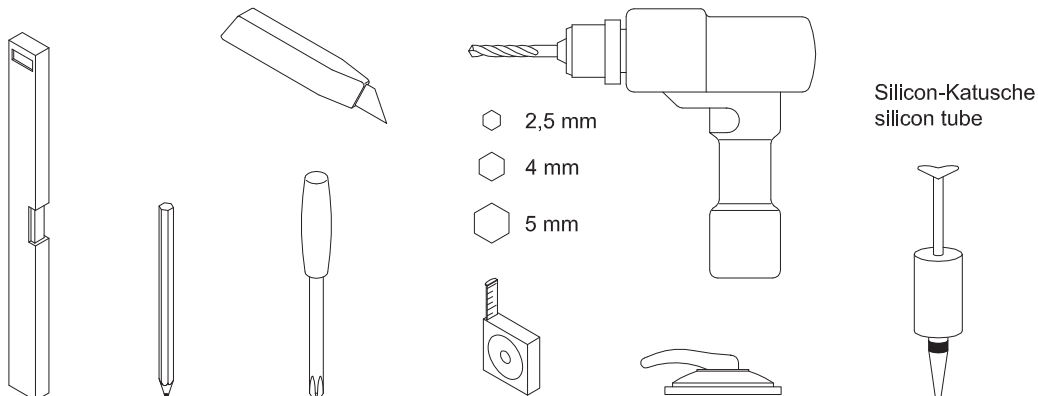

**Lieferumfang:**  
**Scope of delivery:**

DIN links wie gezeichnet / DIN rechts spiegelbildlich  
DIN left shown / DIN right in mirror image

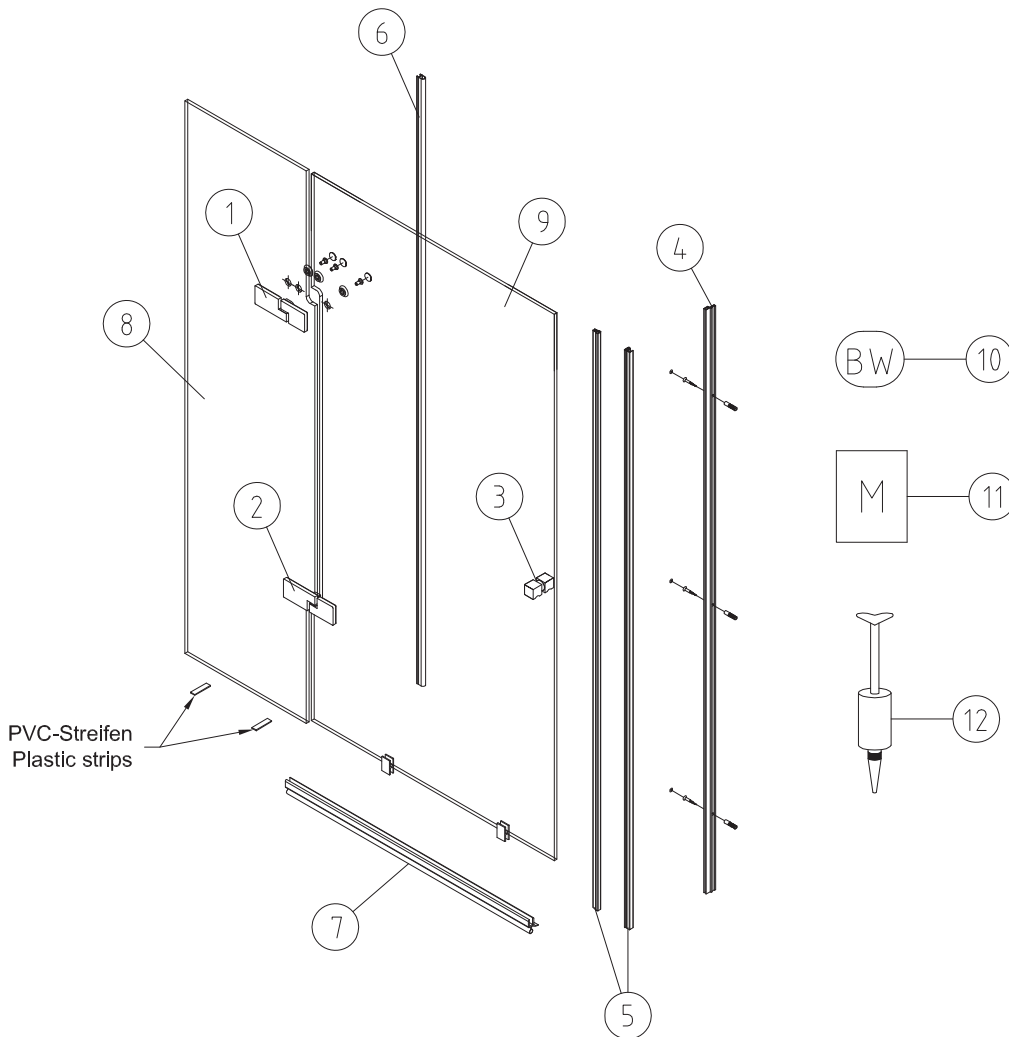

mit Profilbefestigung:  
fixed with profile:

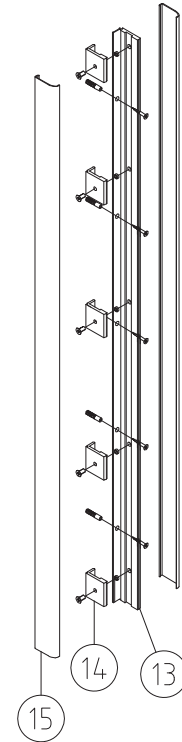

mit Winkelbefestigung:  
fixed with brackets:

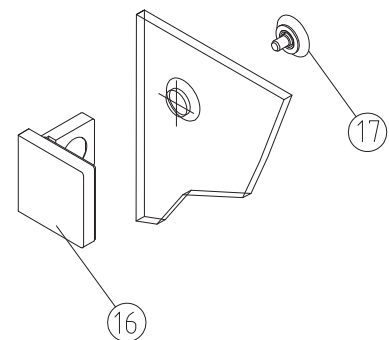

**Material**

- |   |   |
|---|---|
| ① oberes Band G/G / top hinge glass/glass                               | 1 |
| ② unteres Band G/G / bottom hinge glass/glass                           | 1 |
| ③ Türgriff / door handle  | 1 |
| ④ Magnetleistenträger / magnetic support profil                         | 1 |
| ⑤ Pendelmagnetchichtung 90° / magnetic seal 90° for double-action doors | 1 |
| ⑥ Schlauchdichtung Lagerlänge / soft nose seal stock length             | 1 |
| ⑦ Wasserabweiser / water disperser                                      | 1 |
| ⑧ Glas Fixteil (optional) / glass in-line panel (optional)              | 1 |
| ⑨ Glas Drehtür (optional) / glass swing door (optional)                 | 1 |
| ⑩ Beipack Wandbefestigung / fixtures enclosed                           | 1 |
| ⑪ Montageanleitung / assembly instruction                               | 1 |
| ⑫ Silikonkartusche / silicon tube                                       | 1 |

Profilbefestigung / fixed with profiles

- |                               |   |
|-------------------------------|---|
| ⑬ Klemmprofil / clamp profile | 1 |
| ⑭ Klemmstücke / clamps        | 5 |
| ⑮ Clipsprofil / clips profile | 2 |

oder / or

Winkelbefestigung / fixed with brackets

- |                                   |   |
|-----------------------------------|---|
| ⑯ Winkel G/W / bracket glass/wall | 2 |
| ⑰ Versenk / countersink           | 2 |

Einbausituation Profilbefestigung:  
Mounting arrangement fixed with profile:

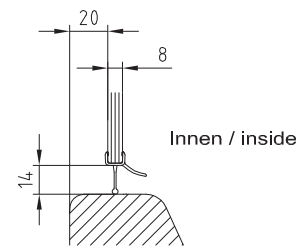
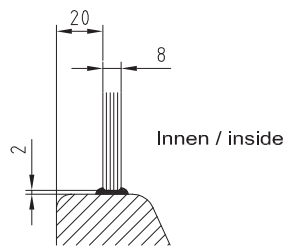
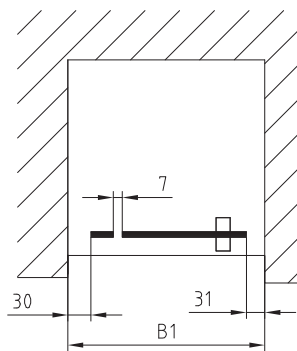

Einbausituation Winkelbefestigung:  
Mounting arrangement fixed with brackets:

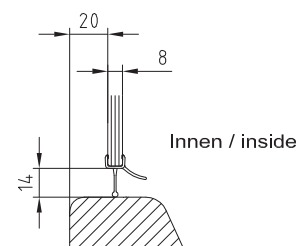
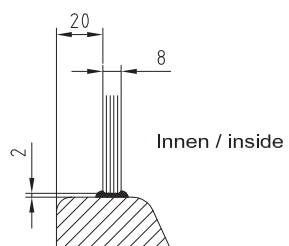
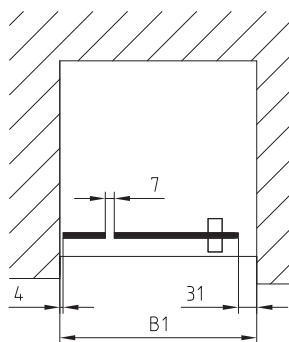

# 1A

## Winkelbefestigung / fixed with brackets

Winkel Glas/Wand an Fixteil schrauben.

Screw on brackets glass/wall onto in-line panel.

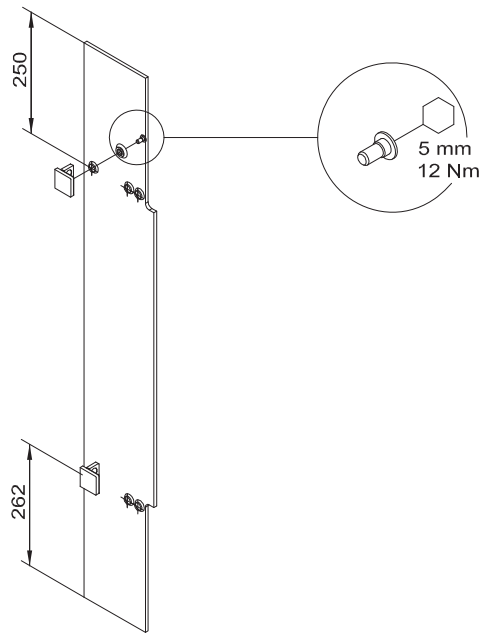

# 2A

PVC-Streifen zur Distanzhaltung unterlegen.

Fixteil ausrichten, anzeichnen, bohren und verschrauben.

Place the plastic-strips under the glass to hold the distance.  
Set up fixed panel, mark, drill and screw on.

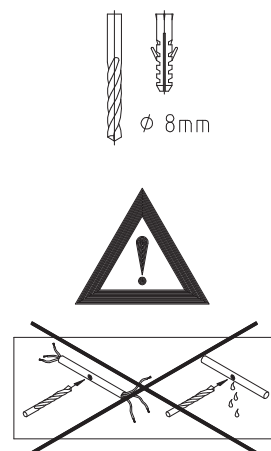
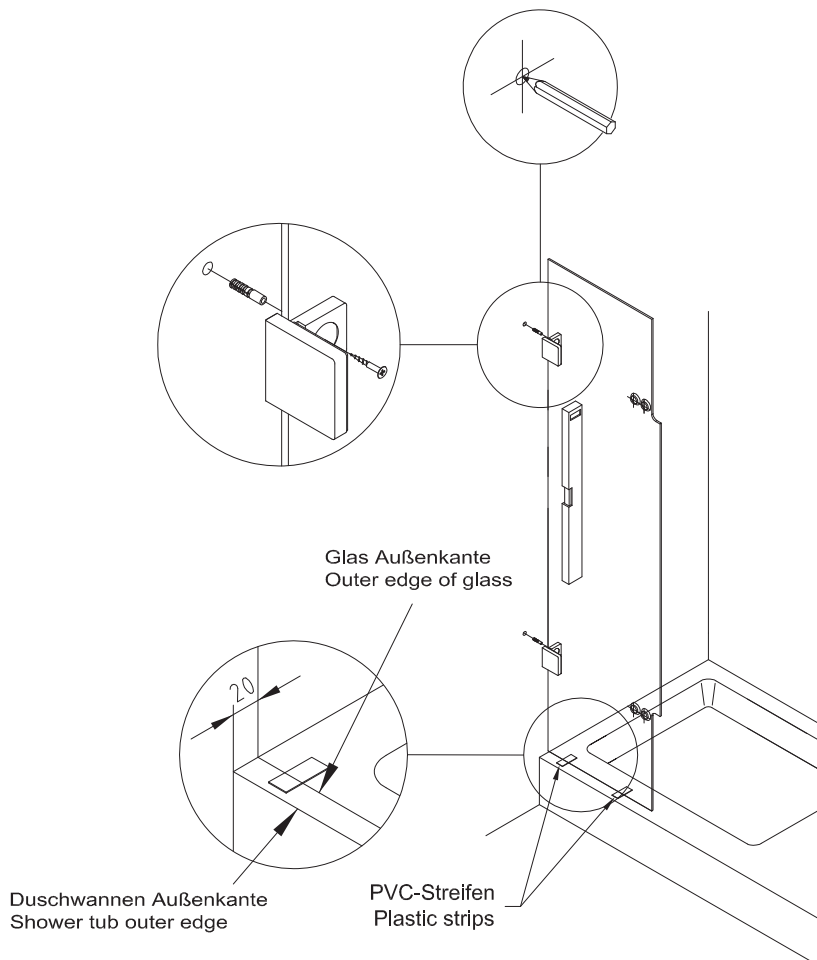

# 1B

## Profilbefestigung / fixed with profile

Klemmprofil ausrichten und Bohrungen anzeichnen.  
Löcher bohren und Klemmprofil anschrauben.

Set up clamp profile and mark the drill holes.  
Drill holes and fix the clamp profile

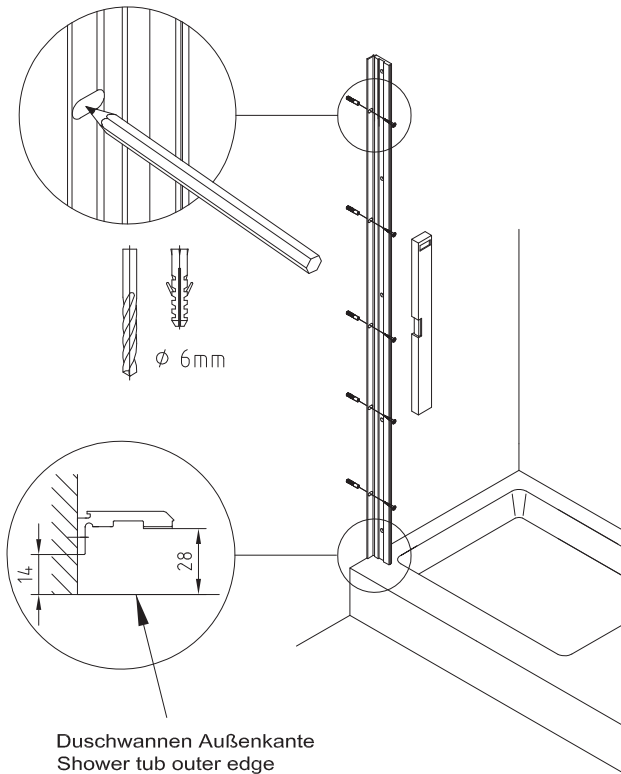

# 2B

PVC-Streifen zur Distanzhaltung unterlegen.  
Fixteil ausrichten und Klemmstücke anschrauben.

Place the plastic-strips under the glass to hold the distance.  
Set up in-line panel and screw on the clamps.

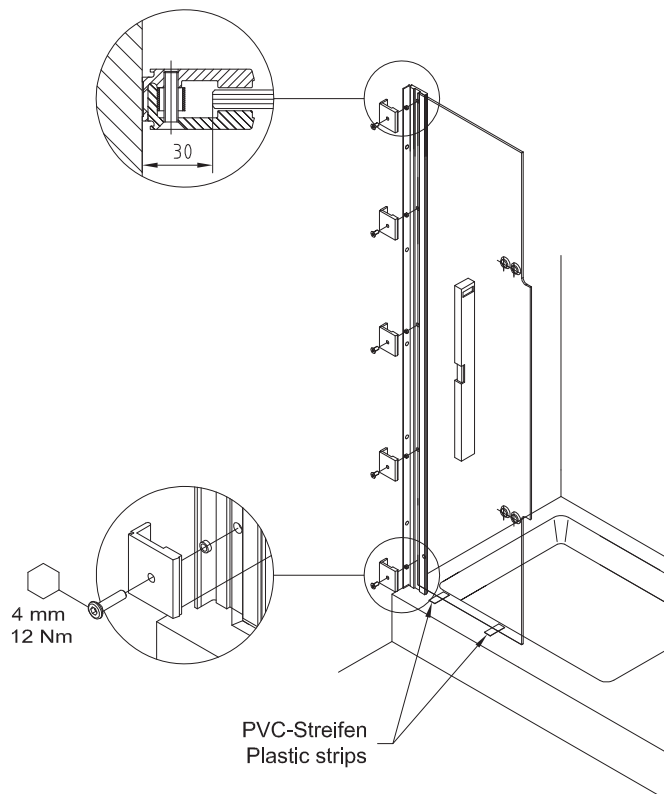

**3**

Rahmenteil des oberen Beschlags an das Fixteil schrauben.

Screw on frame part of top hinge onto in-line panel.

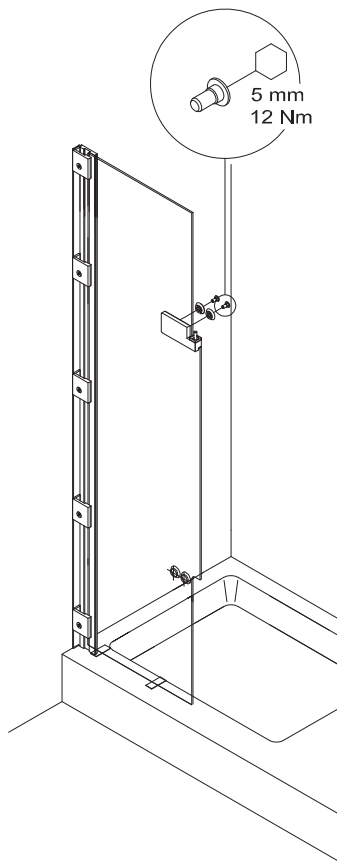

**4**

Unteren Beschlagn in Originalverpackung leicht an das Fixteil schrauben.

Bottom hinge, with original packaging, is to be loosely attached to the in-line panel.

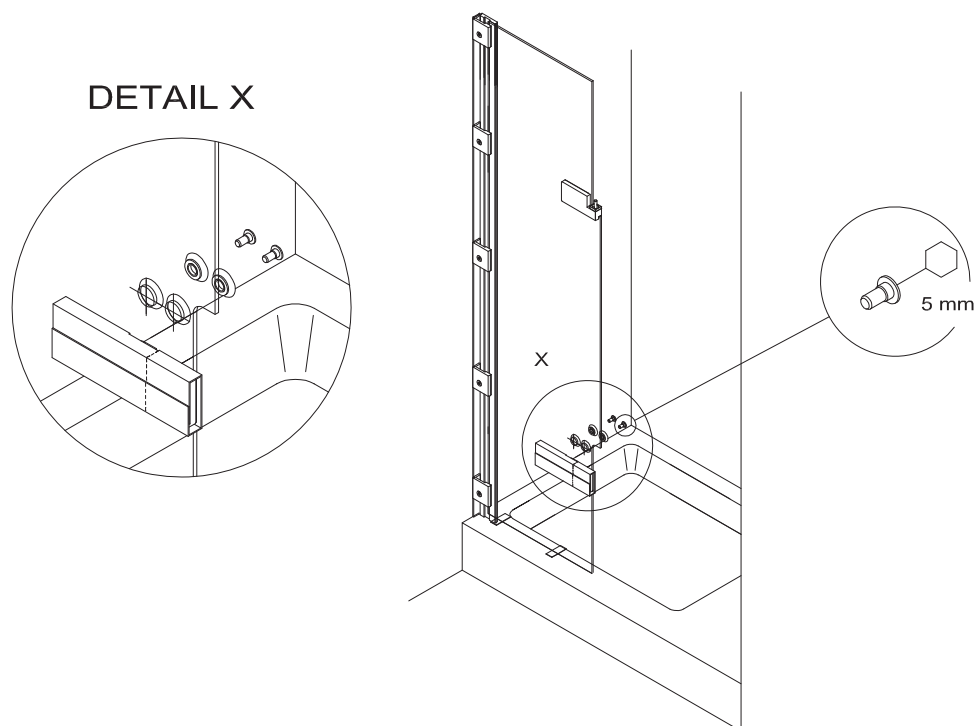

**5**

Flügelteil des oberen Beschlags an die Drehtür schrauben.  
Montagehilfen aufstecken.

Screw on leaf part of top hinge onto swing door.  
Attach the assembly blocks.

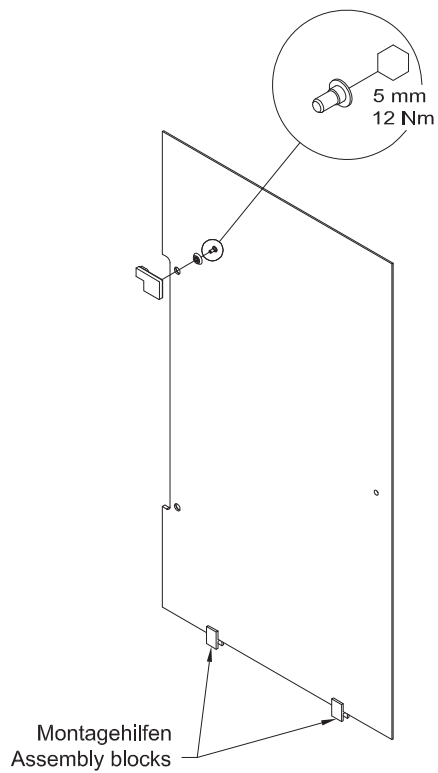

**6**

Glas Drehtür vorsichtig einhängen.

Fit the swing door carefully.

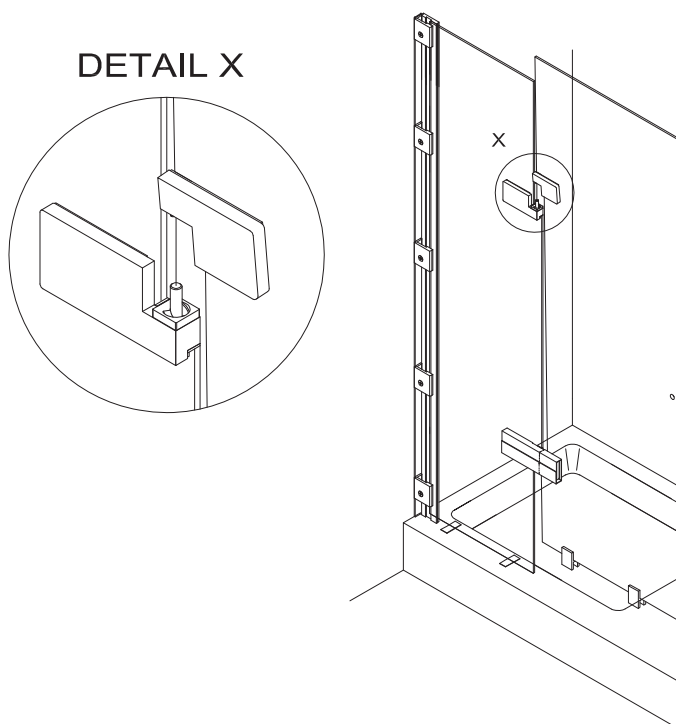



- 7** Unteren Beschlag in Originalverpackung leicht an die Drehtür schrauben.  
Bottom hinge, with original packaging, is to be loosely attached to the glass swing door.

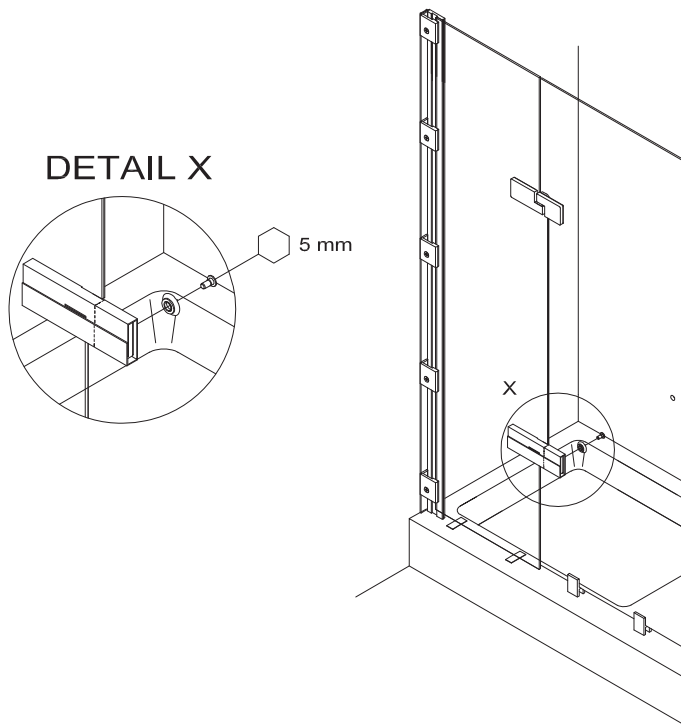

- 8** Originalverpackung am unteren Beschlag entfernen.  
Remove the original packaging at bottom hinge.

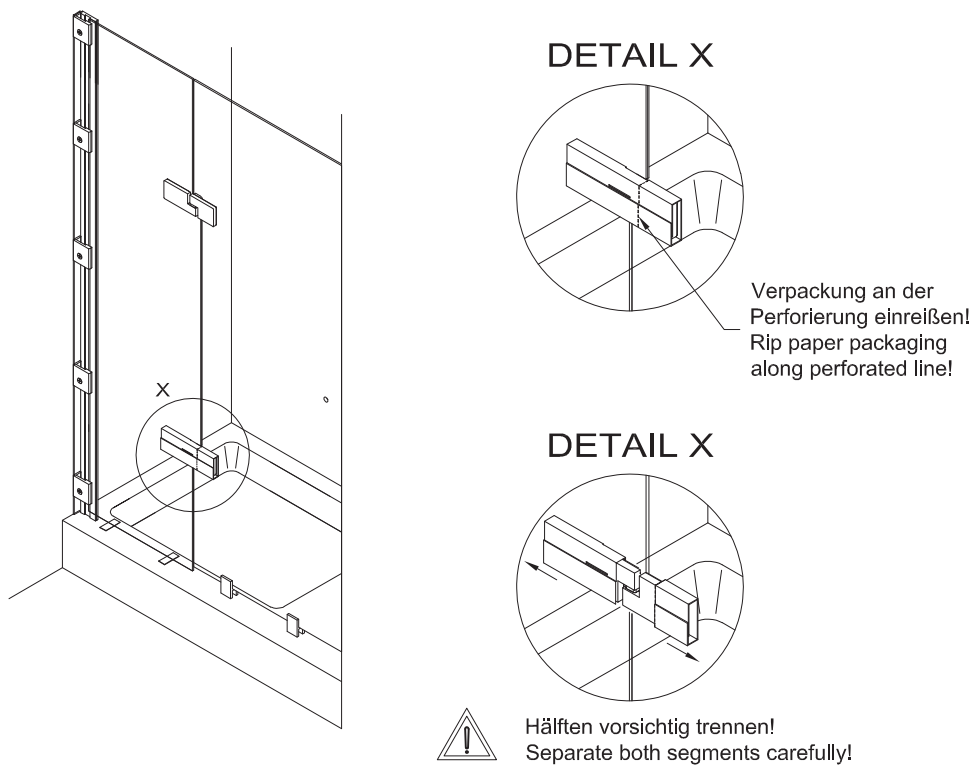

# 9

Glas Drehtür ausrichten und Schrauben anziehen.  
Adjust the glass swing door and tighten hinge screws.

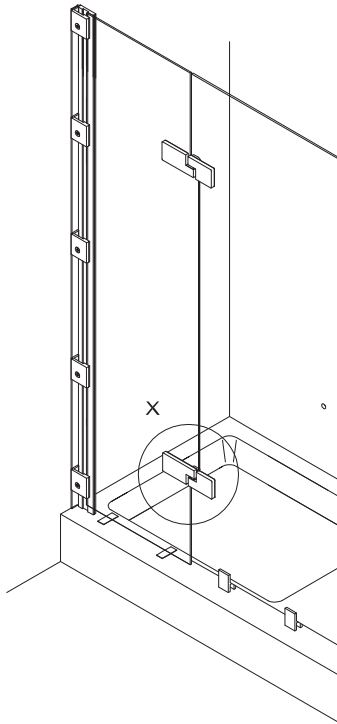

## DETAIL X

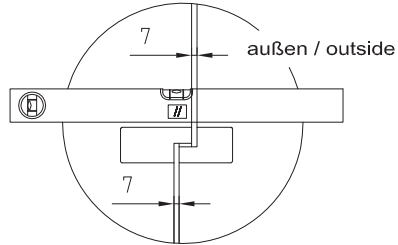

## DETAIL X

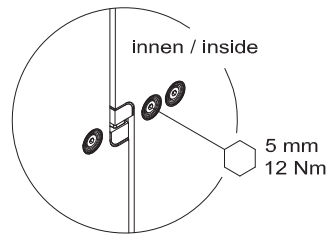

# 10

Obere und untere Dichtungen einpassen und auf das Fixteil aufstecken.  
Conform the top and bottom seal with glass and attach onto in-line panel.

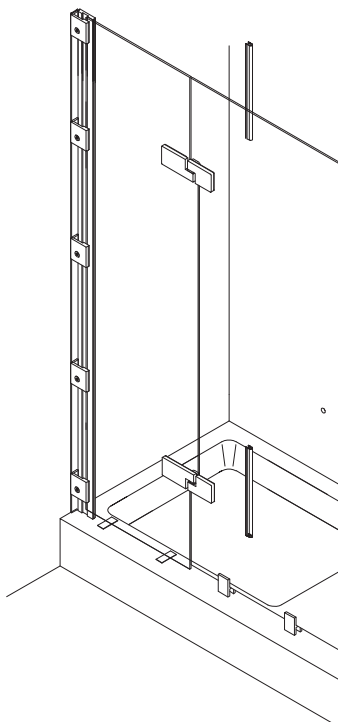

## Ausschnitt / cut out

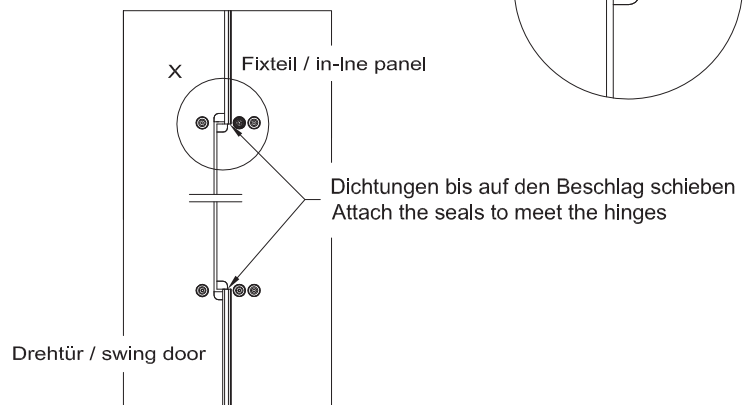

## DETAIL X

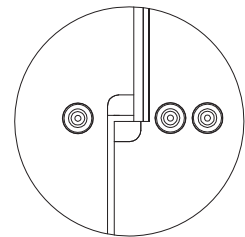

**11**

Mittlere Dichtung einpassen und auf die Drehtür aufstecken.  
Conform the middle seal with glass and attach onto swing door.

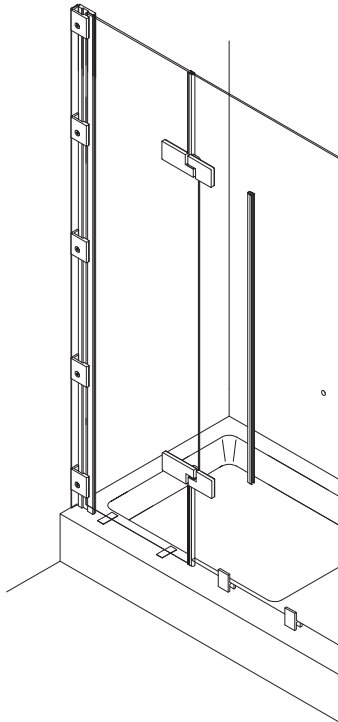

Ausschnitt / cut out

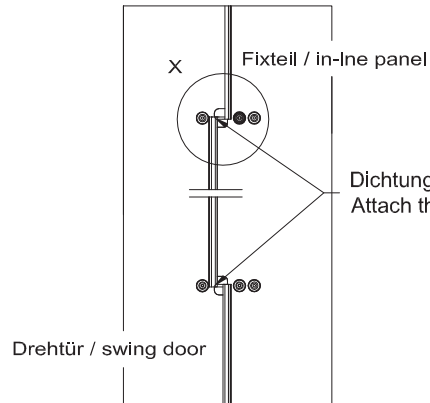

DETAIL X

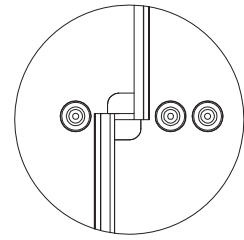

**12**

Magnetdichtung auf die Drehtür aufstecken.  
Attach the magnetic seal at swing door.

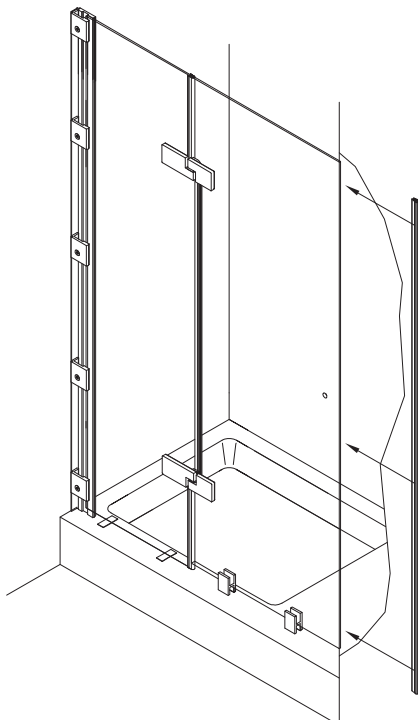

# 13

Türgriff montieren.  
Assembly of door handle.

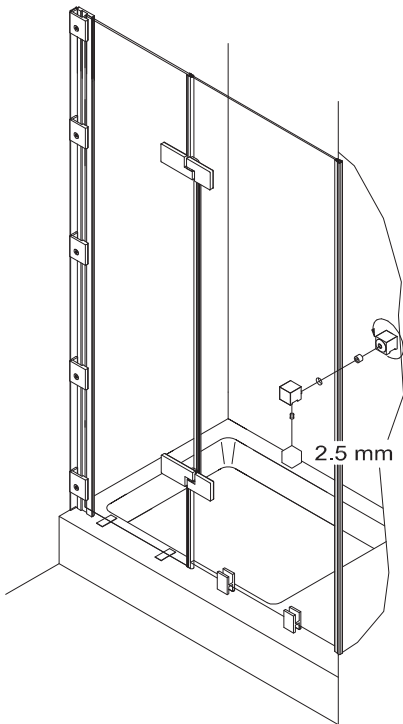

# 14

Magnetdichtung auf den Magnetleistenträger stecken.  
Magnetleistenträger ausrichten, markieren, bohren und verschrauben.

Attach the magnetic seal onto magnetic support profile.  
Adjust the magnetic support profile, mark, drill and screw on.

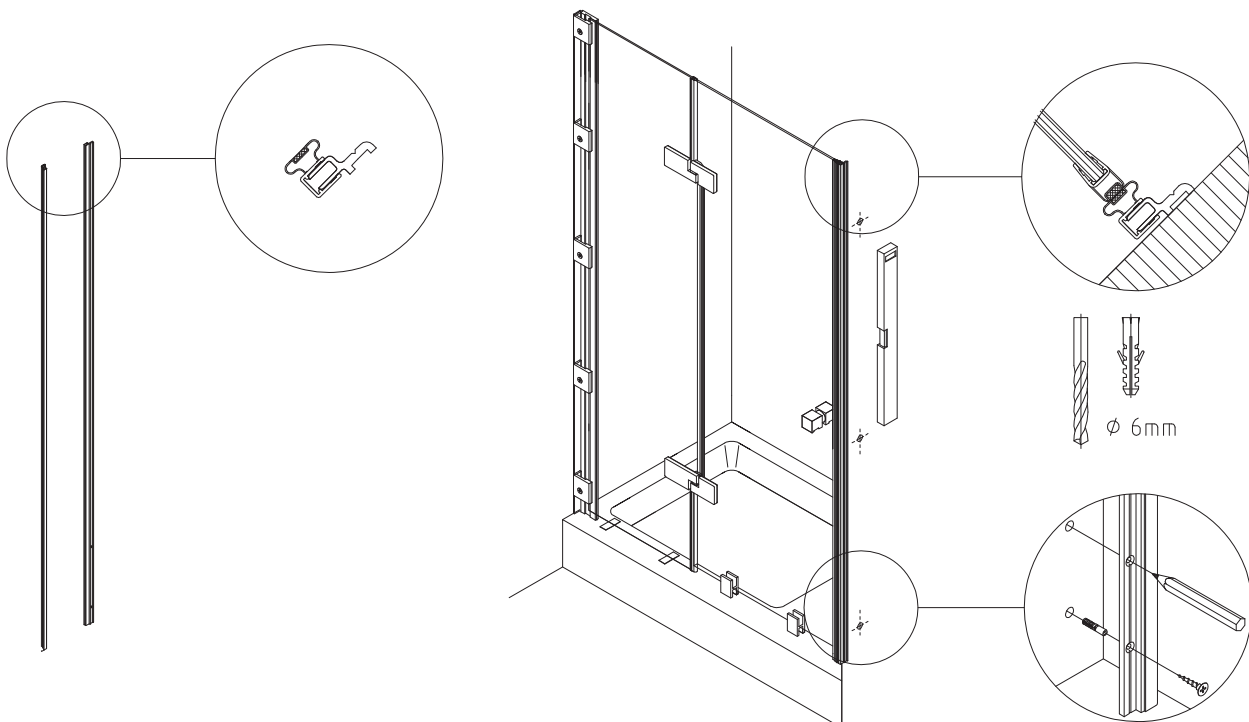

1. PVC-Streifen vorsichtig kürzen.
2. Clipsprofil aufstecken.
3. Montagehilfen entfernen. Wasserabweiser anpassen und aufstecken.
4. Clipsprofil, Magneteleistenträger und Fixteil versiegeln.
5. Kappen aufkleben und aufstecken.

1. Shorten plastic strips carefully.
2. Attach the clips profile.
3. Take of assembly blocks. Conform and attach the water disperser.
4. Seal up the clips profile, the magnetic support profile and the in-line panel.
5. Glue on and attach cover caps.

**Winkelbefestigung**  
**Fixed with brackets**

**Profilbefestigung**  
**Fixed with profiles**

