

**Montageanleitung
BH 2401 / TYP 220
Eckkabine, 2 Drehtüren
an Fixteilen, mit Winkel-/
Profilbefestigung**

**Assembly instruction
BH 2401 / TYPE 220
corner cubicle, 2 swing
doors fixed to in-line panels,
fixed with brackets/profiles**

Wichtige Informationen:
Important information:

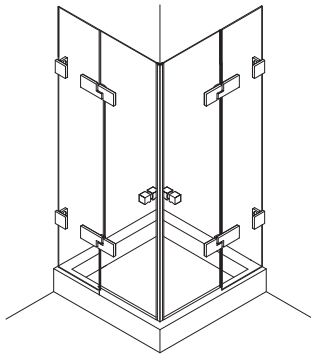

mit Winkelbefestigung
fixed with brackets

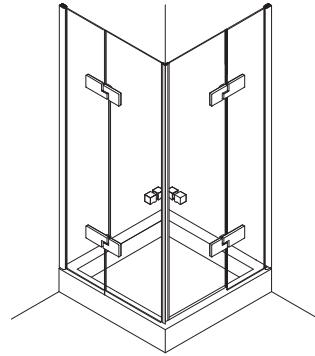

mit Profilbefestigung
fixed with profiles

Vor der Montage Glasflächen
mit handelsüblichem Glasreiniger
im Bereich der Klemmflächen reinigen.

All glass clamping areas are to
be cleaned with standard glass
cleaning products prior to installation.



keine Verdünnung verwenden
Do not use thinners

Wichtiger Hinweis

Glas beim Auspacken immer mit Schutz (Pappe oder Ähnlichem) auf den Fußboden stellen.
Kanten und Ecken des Glases nicht anstoßen lassen.

Konstruktionsbedingt ist bei rahmenlosen Duschtrennungen keine absolute Abdichtung erreichbar.
Die Montage der jeweils beiliegenden Dichtlippen gewährleistet die maximal erreichbare Dichtigkeit.
Alle Maßangaben in mm!

Important notice!

While unpacking the glass always use the protection of the wood or cardboard, as available and set it on the floor. Be careful not to bump into anything with the trim and edges of the glass.
Because of the construction of the frameless shower enclosure a complete seal cannot be obtained.
The installation of the enclosed seals, provide the maximal obtainable sealant.
All measurements are in mm.

Montagewerkzeug:
Mounting tool:

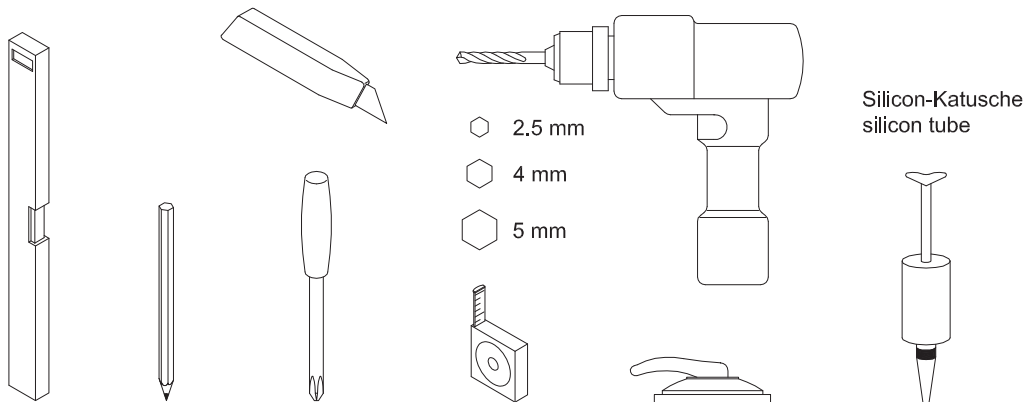

Lieferumfang:
Scope of delivery:

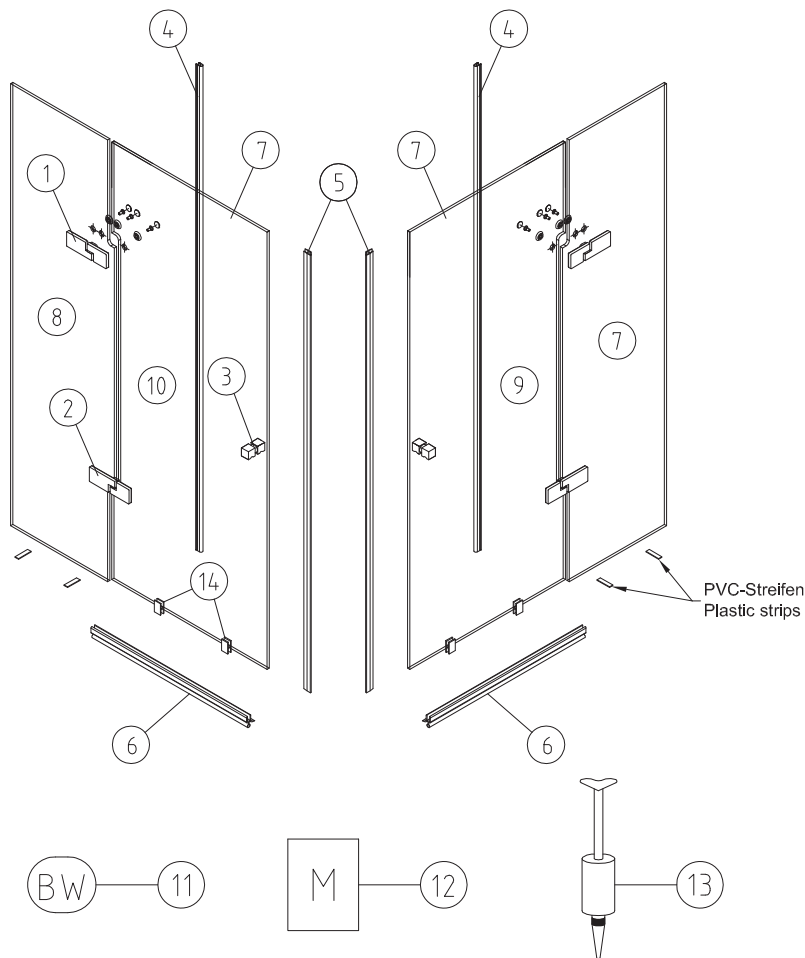

mit Profilbefestigung:
fixed with profile:

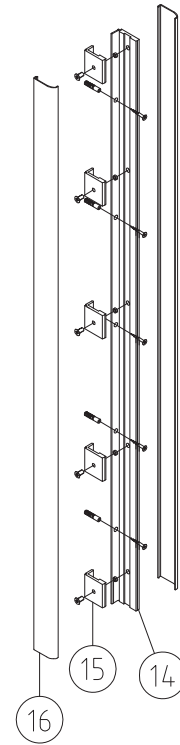

mit Winkelbefestigung:
fixed with brackets:

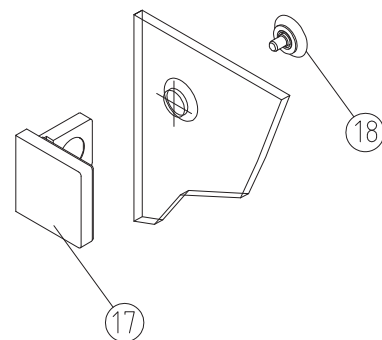

Material

- ① Oberes Band G/G / top hinge glass/glass
- ② Unteres Band G/G / bottom hinge glass/glass
- ③ Türgriff / door handle
- ④ Schlauchdichtung Lagerlänge / soft nose seal stock length
- ⑤ Magnetdichtung 90° / magnetic seal 90°
- ⑥ Wasserabweiser / water disperser
- ⑦ Glas Fixteil rechts / glass in-line panel RH
- ⑧ Glas Fixteil links / glass in-line panel LH
- ⑨ Glas Drehtür rechts / glass swing door RH
- ⑩ Glas Drehtür links / glass swing door LH
- ⑪ Beipack Wandbefestigung / fixtures enclosed
- ⑫ Montageanleitung / assembly instruction
- ⑬ Silikonkartusche / silicon tube

2		
2		
2		
2		
1		
2	<u>Profilbefestigung / fixed with profiles</u>	
1	⑭ Klemmprofil / clamp profile	2
1	⑮ Klemmstücke / clamps	10
1	⑯ Clipsprofil / clips profile	4
1	oder / or	
1	<u>Winkelbefestigung / fixed with brackets</u>	
1	⑰ Winkel G/W / bracket glass/wall	4
1	⑱ Versenk / countersink	4

Einbausituation Profilbefestigung:
Mounting arrangement fixed with profile:

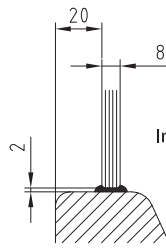
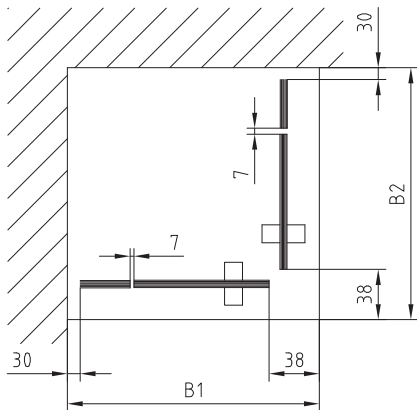

Innen / inside

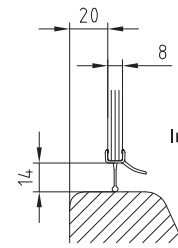

Innen / inside

Einbausituation Winkelbefestigung:
Mounting arrangement fixed with brackets:

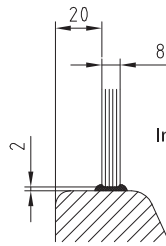
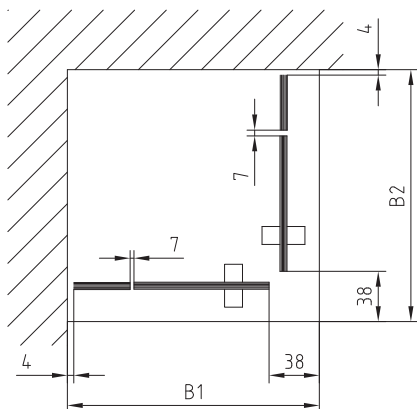

Innen / inside

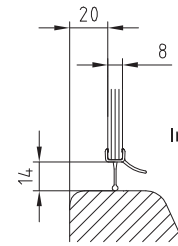

Innen / inside

1A

Winkelbefestigung / fixed with brackets

Winkel Glas/Wand an Fixteile schrauben.

Screw on brackets glass/wall onto in-line panels.

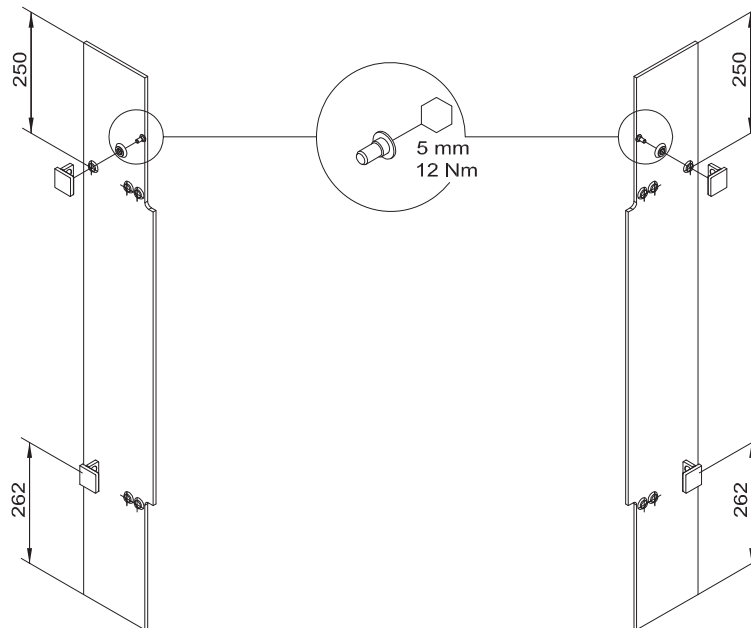

2A

PVC-Streifen zur Distanzhaltung unterlegen.

Fixteile ausrichten, anzeichnen, bohren und verschrauben.

Place the plastic-strips under the glass to hold the distance.
Set up in-line panels, mark, drill and screw on.

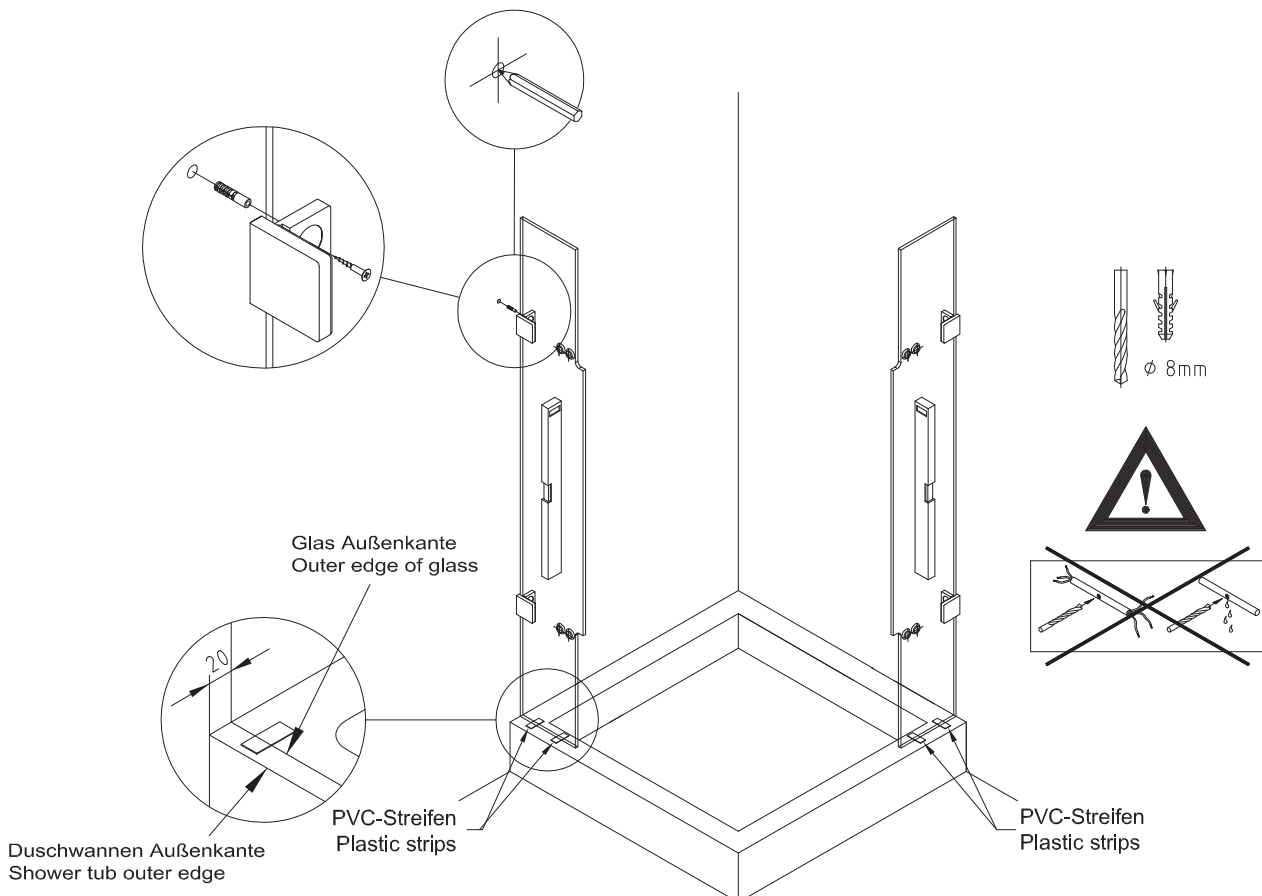

1B

Profilbefestigung / fixed with profile

Klemmprofile ausrichten und Bohrungen anzeichnen.
Löcher bohren und Klemmprofile anschrauben.

Set up clamp profiles and mark the drill holes.
Drill holes and fix the clamp profiles.

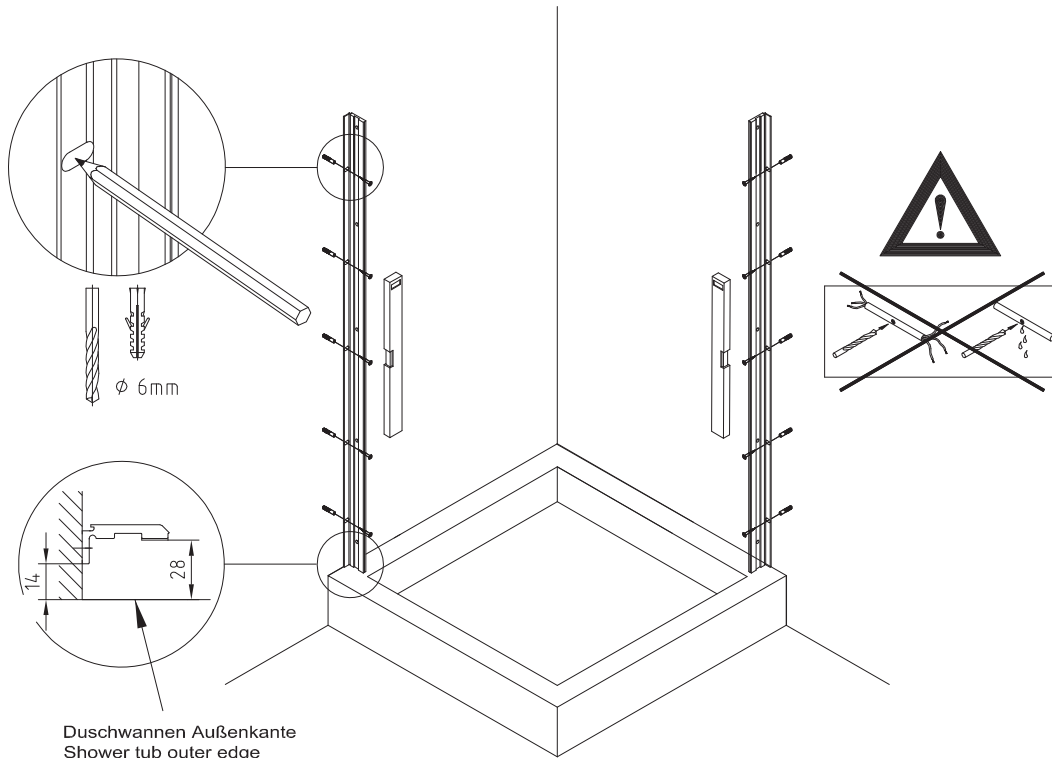

2B

PVC-Streifen zur Distanzhaltung unterlegen. Fixteile ausrichten und Klemmstücke anschrauben.

Place the plastic-strips under the glass to hold the distance.
Set up in-line panels and screw on the clamps.

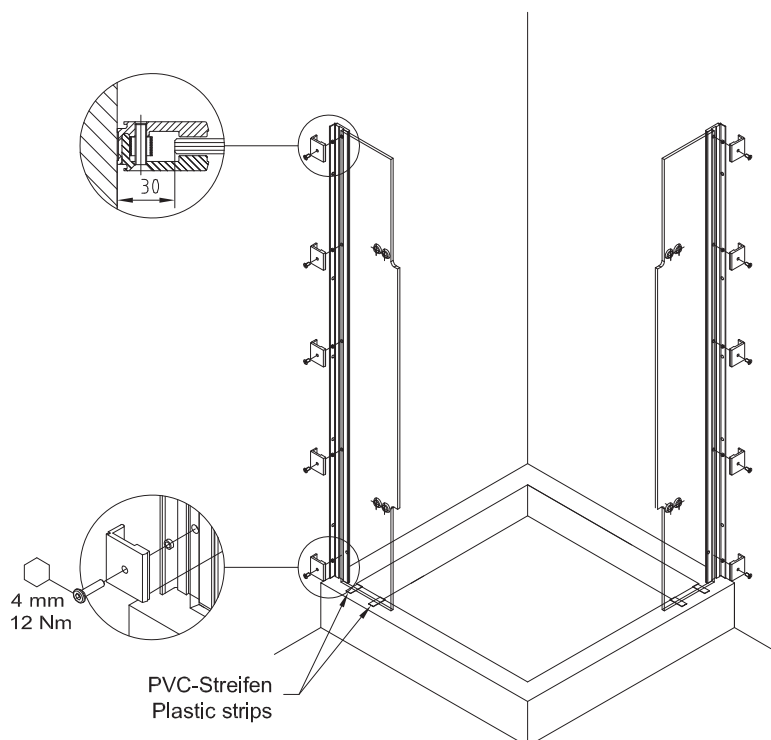

3

Rahmenteile der oberen Beschläge an die Fixteile schrauben.

Screw on frame parts of top hinges onto in-line panels.

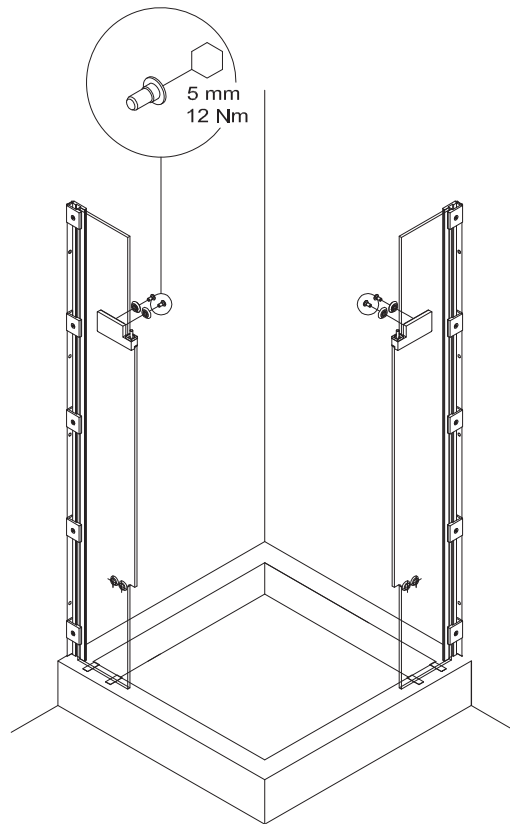

4

Untere Beschläge in Originalverpackung leicht an die Fixteile schrauben.

Bottom hinges, with original packaging, is to be loosely attached to the in-line panels.

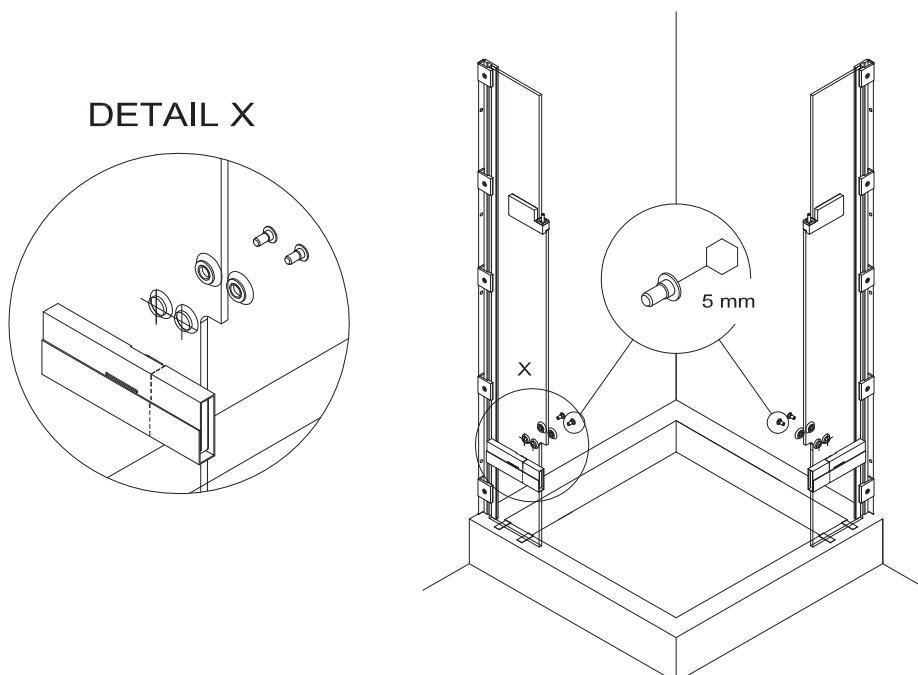

5

Flügelteile der oberen Beschläge an die Drehtüren schrauben.
Montagehilfen und Magnetdichtungen aufstecken.

Screw on leaf parts of top hinges onto swing doors.
Attach the assembly blocks and magnetic seals.

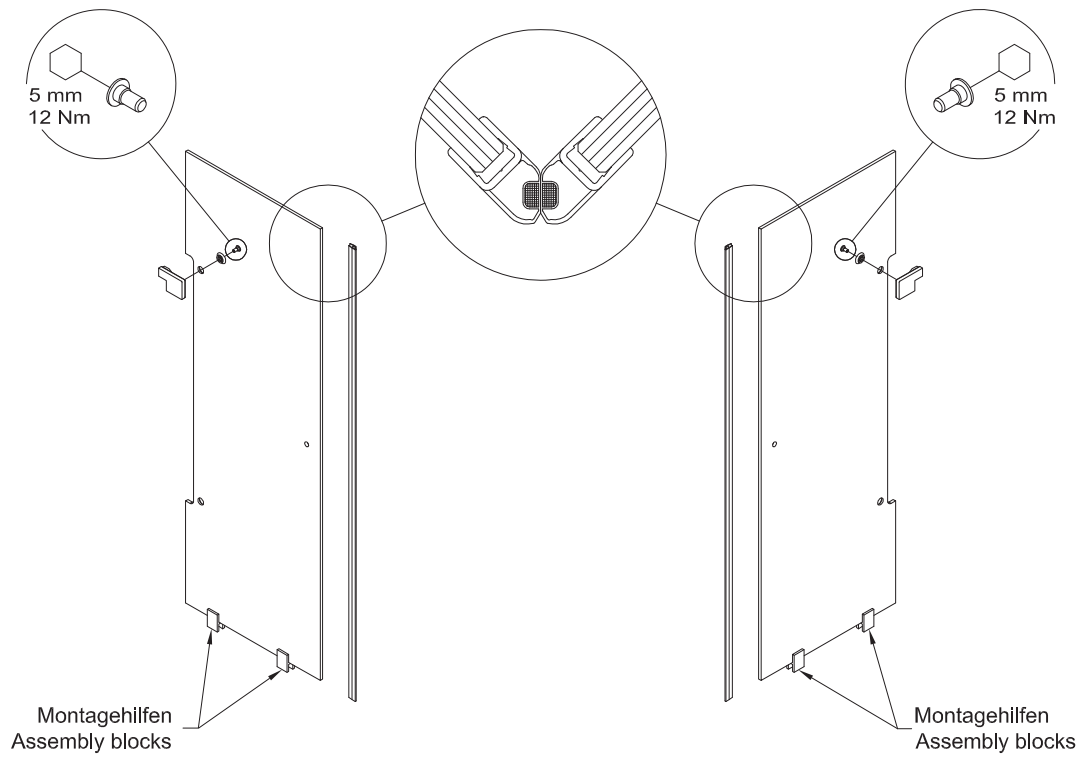

6

Glas Drehtür vorsichtig einhängen.

Fit the swing door carefully.

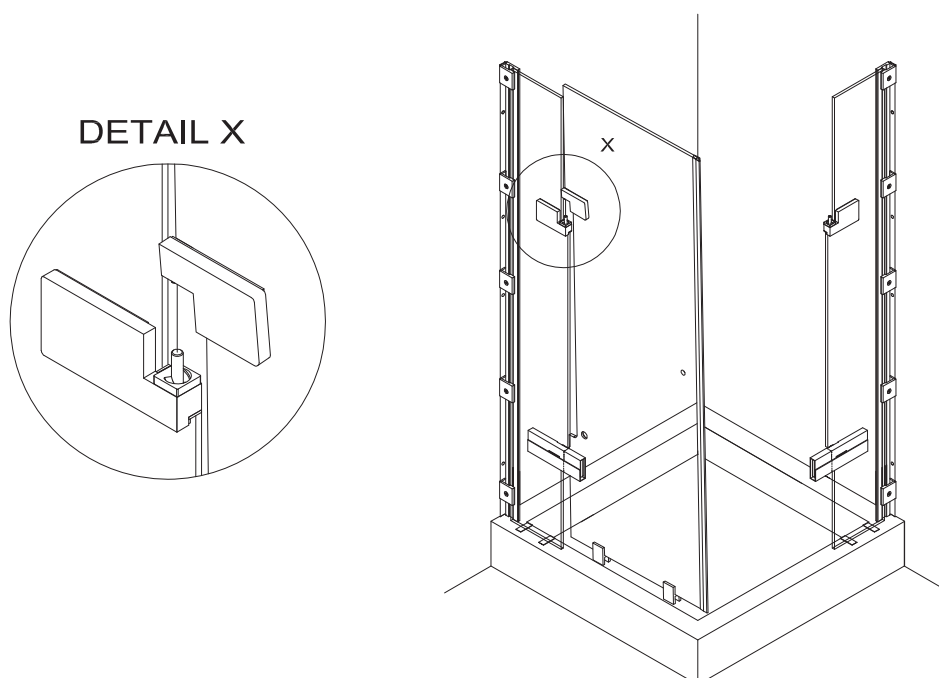

7

Unteren Beschlag in Originalverpackung leicht an die Drehtür schrauben.

Bottom hinge, with original packaging, is to be loosely attached to the glass swing door.

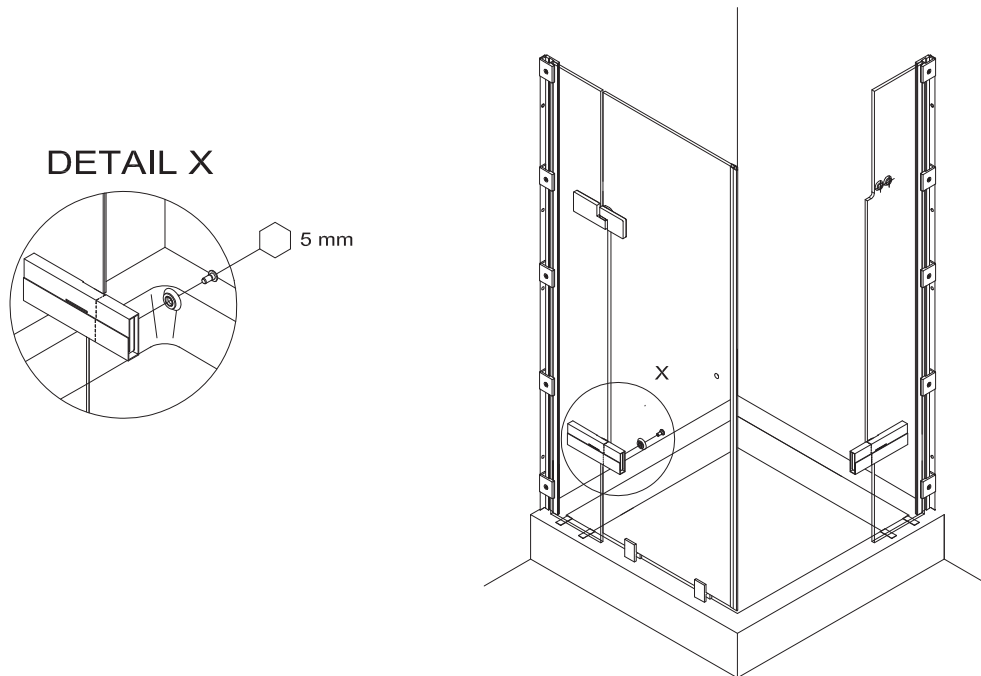

8

Originalverpackung am unteren Beschlag entfernen.

Remove the original packaging at bottom hinge.

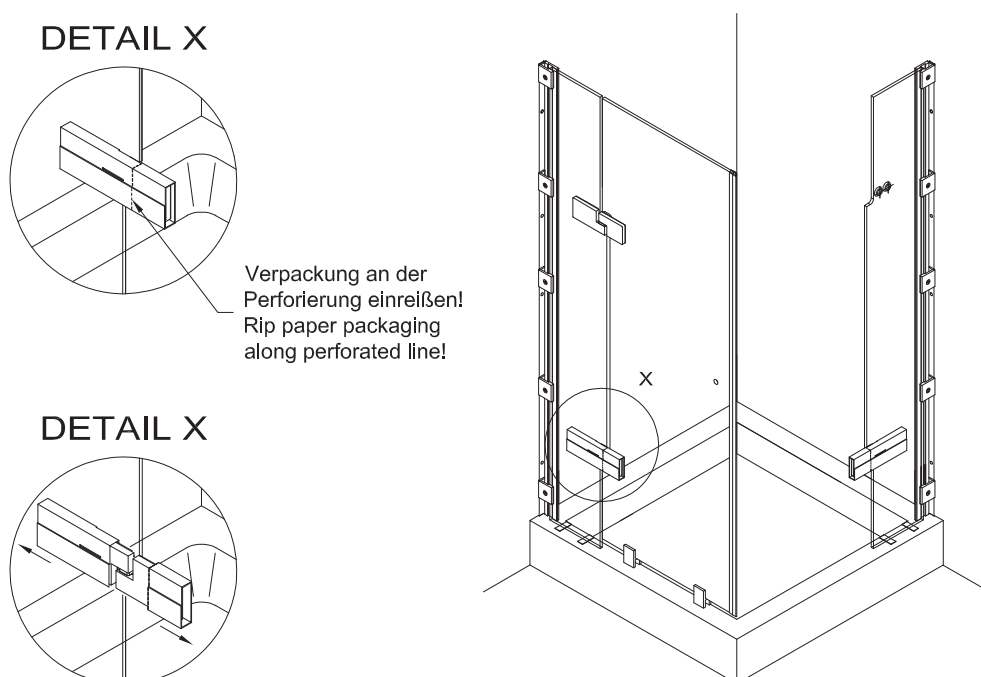

Hälften vorsichtig trennen!
Separate both segments carefully!

- 9** Glas Drehtür ausrichten und Schrauben anziehen.
Adjust the glass swing door and tighten hinge screws.

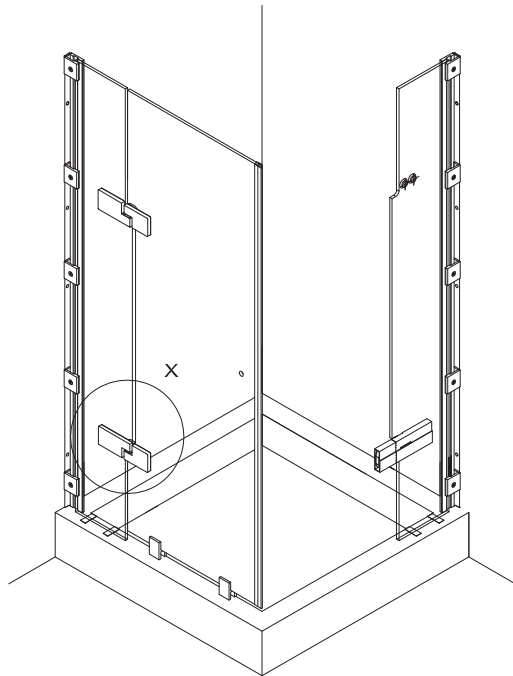

DETAIL X

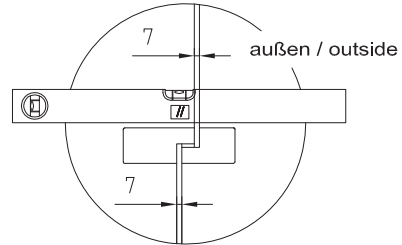

DETAIL X

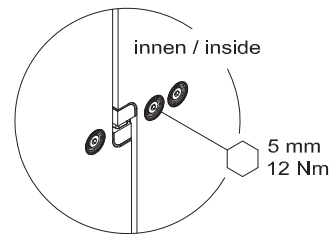

- 10** Glas Drehtür vorsichtig einhängen.
Fit the swing door carefully.

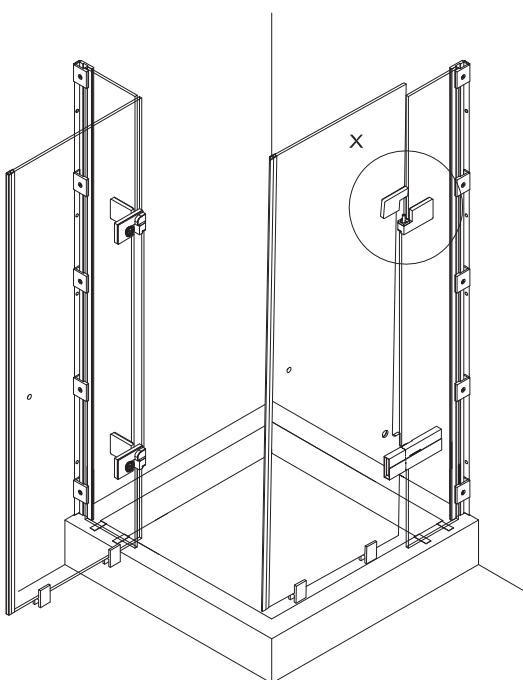

DETAIL X

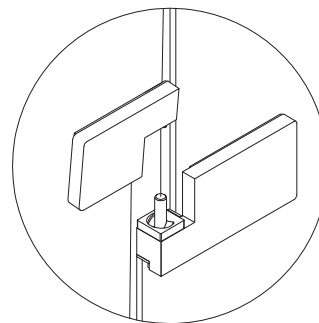

11

Unteren Beschlag in Originalverpackung leicht an die Drehtür schrauben.

Bottom hinge, with original packaging, is to be loosely attached to the glass swing door.

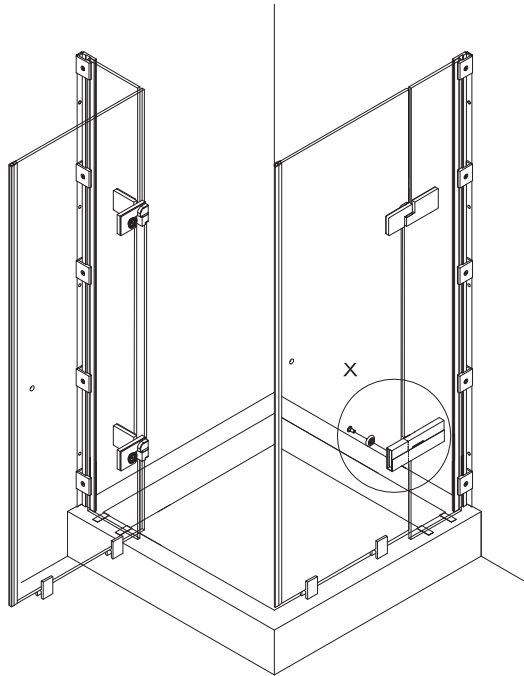

DETAIL X

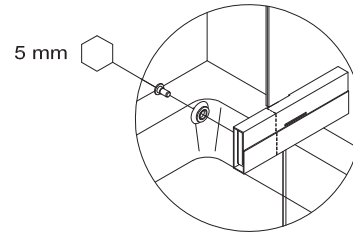

12

Originalverpackung am unteren Beschlag entfernen.

Remove the original packaging at bottom hinge.

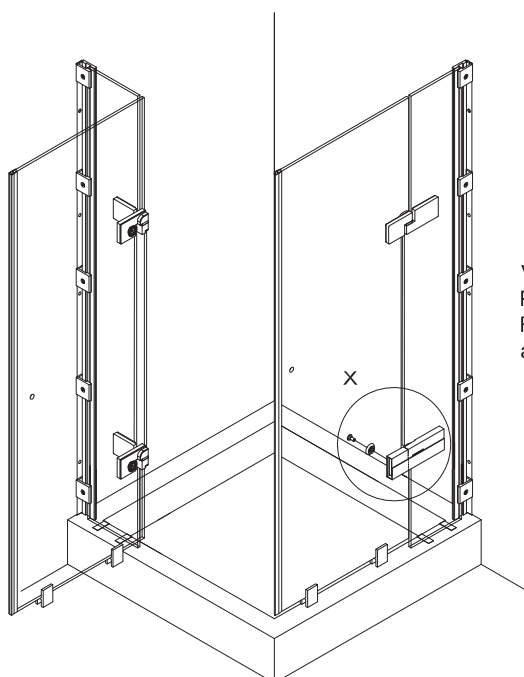

DETAIL X

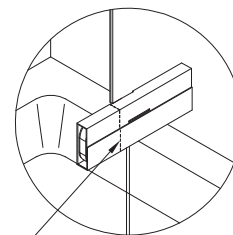

Verpackung an der Perforierung einreißen!
Rip paper packaging along perforated line!

DETAIL X

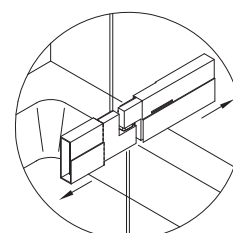

Hälften vorsichtig trennen!
Separate both segments carefully!

13

Glas Drehtür ausrichten und Schrauben anziehen.
Adjust the glass swing door and tighten hinge screws.

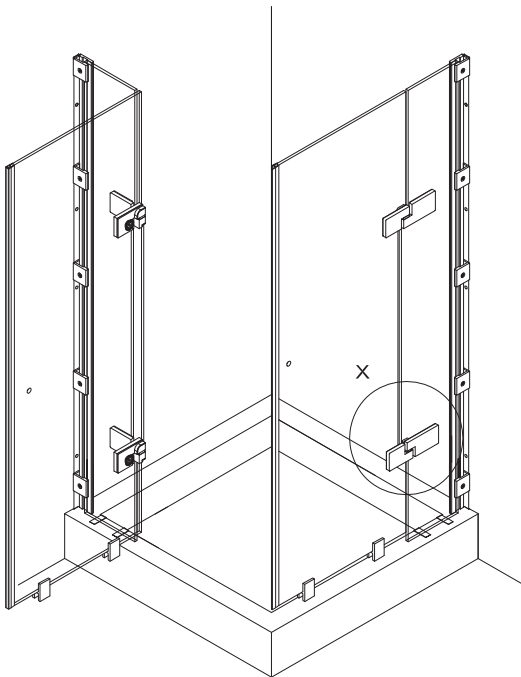

DETAIL X

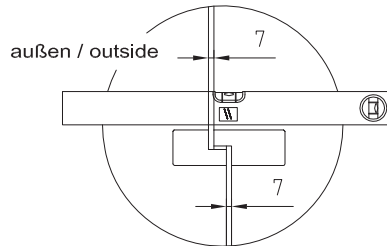

DETAIL X

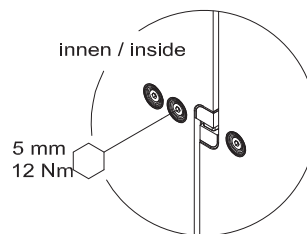

14

Obere und untere Dichtungen einpassen und auf die Fixteile aufstecken.
Conform the top and bottom seals with glass and attach onto in-line panels.

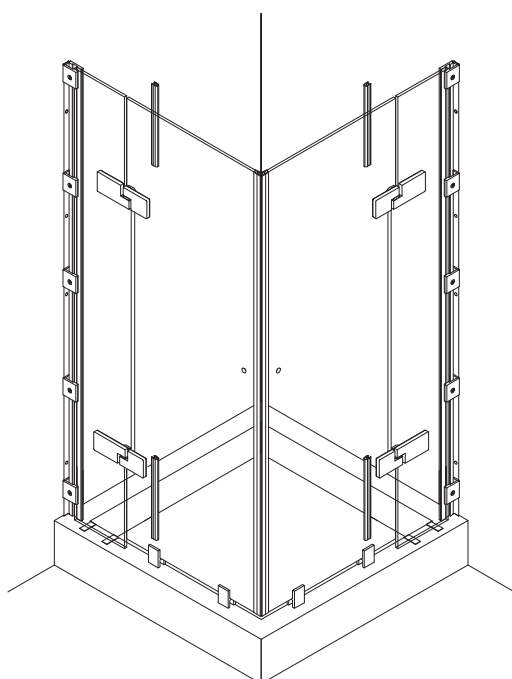

DETAIL X

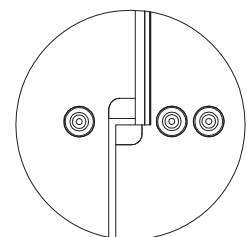

Ausschnitt / cut out
Ansicht von innen / view from the inside

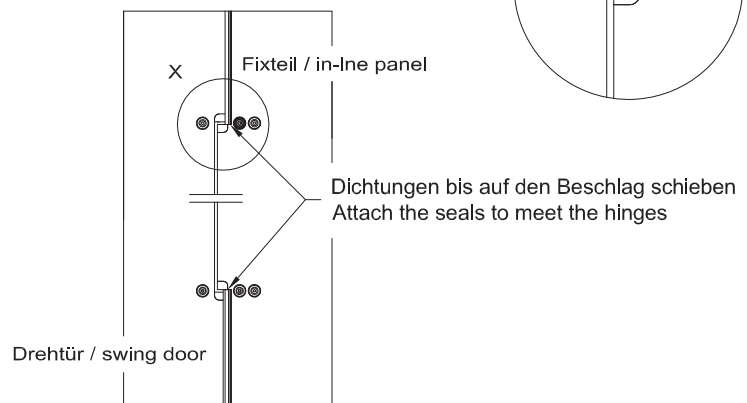

15

Mittlere Dichtungen einpassen und auf die Drehtüren aufstecken.
Conform the middle seals with glass and attach onto swing doors.

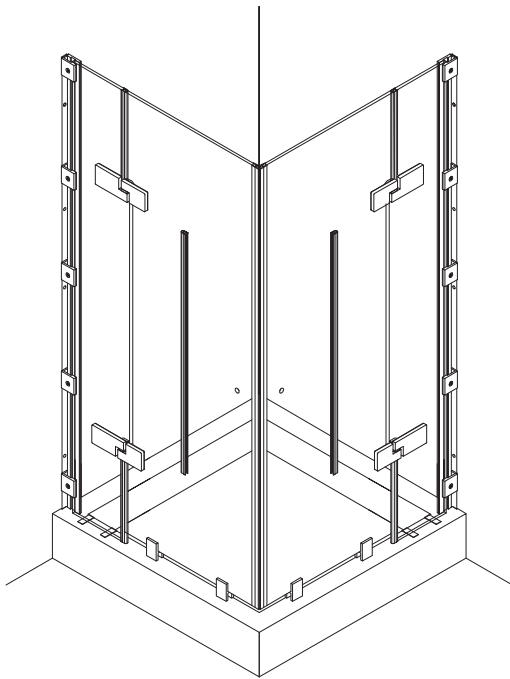

Ausschnitt / cut out

Ansicht von innen / view from the inside

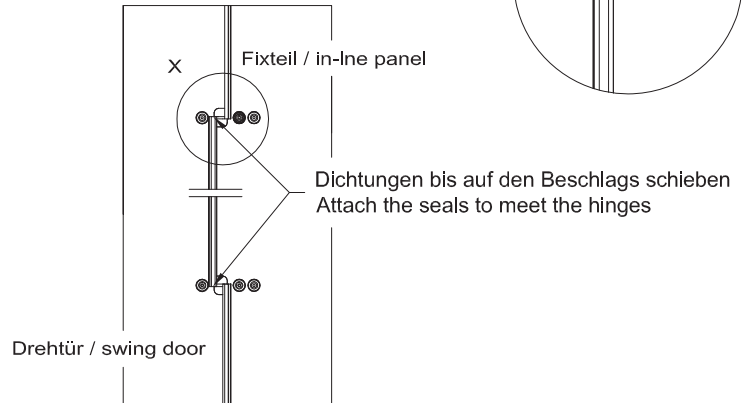

DETAIL X

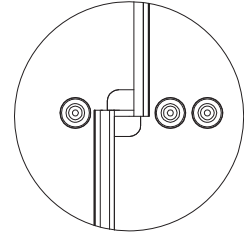

16

Türgriffe montieren.
Assembly of door handles.

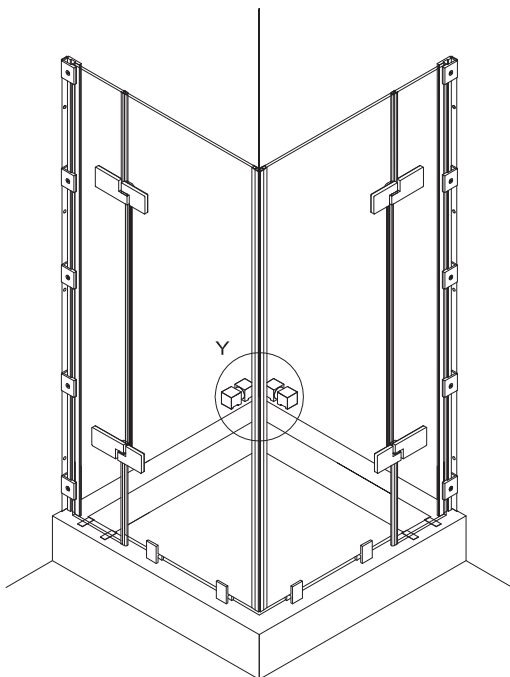

DETAIL Y

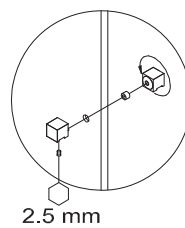

17

1. PVC-Streifen vorsichtig kürzen.
2. Clips Profil aufstecken.
3. Montagehilfen entfernen. Wasserabweiser anpassen und aufstecken.
4. Fixteile und Clipsprofile versiegeln.
5. Abdeckkappen einclipsen.

1. Shorten plastic strips carefully.
2. Put on clips profile.
3. Remove the assembly blocks. Conform and attach the water disperser.
4. Seal up in-line panels and clips profiles.
5. Clip the cover caps.

Winkelbefestigung
Fixed with brackets

Profilbefestigung
Fixed with profiles

Winkelbefestigung
Fixed with brackets

Profilbefestigung
Fixed with profiles

