

**Montageanleitung
BH 2401 / TYP 231
Eckkabine, 1 Drehtür am Fixteil,
1 verkürzte Seitenwand
mit Profil- oder Winkelbefestigung**

**Installation instruction
BH 2401 / TYPE 231
corner cubicle with
1 shortened side panel,
fixed with profiles or brackets**

Wichtige Informationen:
Important information:

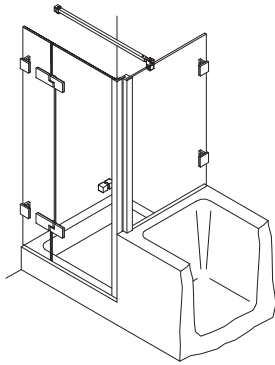

mit Winkelbefestigung
fixed with brackets

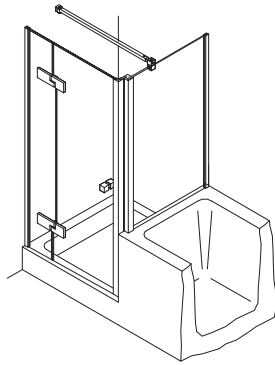

mit Profilbefestigung
fixed with profiles

Vor der Montage Glasflächen mit handelsüblichem Glasreiniger im Bereich der Klemmflächen reinigen.

All glass clamping areas are to be cleaned with standard glass cleaning products prior to installation.



keine Verdünnung verwenden
Do not use thinners

Wichtiger Hinweis

Glas beim Auspacken immer mit Schutz (Pappe oder Ähnlichem) auf den Fußboden stellen. Kanten und Ecken des Glases nicht anstoßen lassen.

Konstruktionsbedingt ist bei rahmenlosen Duschabtrennungen keine absolute Abdichtung erreichbar. Die Montage der jeweils beiliegenden Dichtlippen gewährleistet die maximal erreichbare Dichtigkeit. Alle Maßangaben in mm!

Important notice!

While unpacking the glass always use the protection of the wood or cardboard, as available and set it on the floor. Be careful not to bump into anything with the trim and edges of the glass. Because of the construction of the frameless shower enclosure a complete seal cannot be obtained. The installation of the enclosed seals, provide the maximal obtainable sealant. All measurements are in mm.

Montagewerkzeug:
Mounting tool:

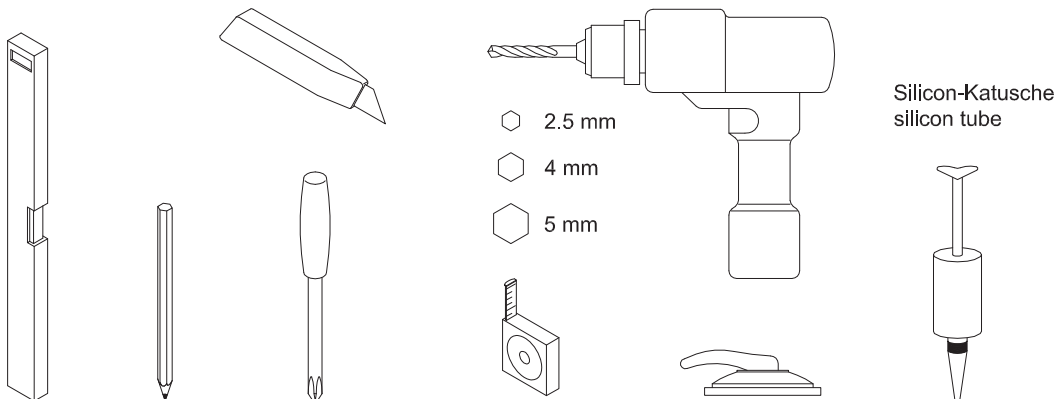

Lieferumfang:
Scope of delivery:

DIN links wie gezeichnet / DIN rechts spiegelbildlich
DIN left shown / DIN right in mirror image

mit Profilbefestigung:
fixed with profile:

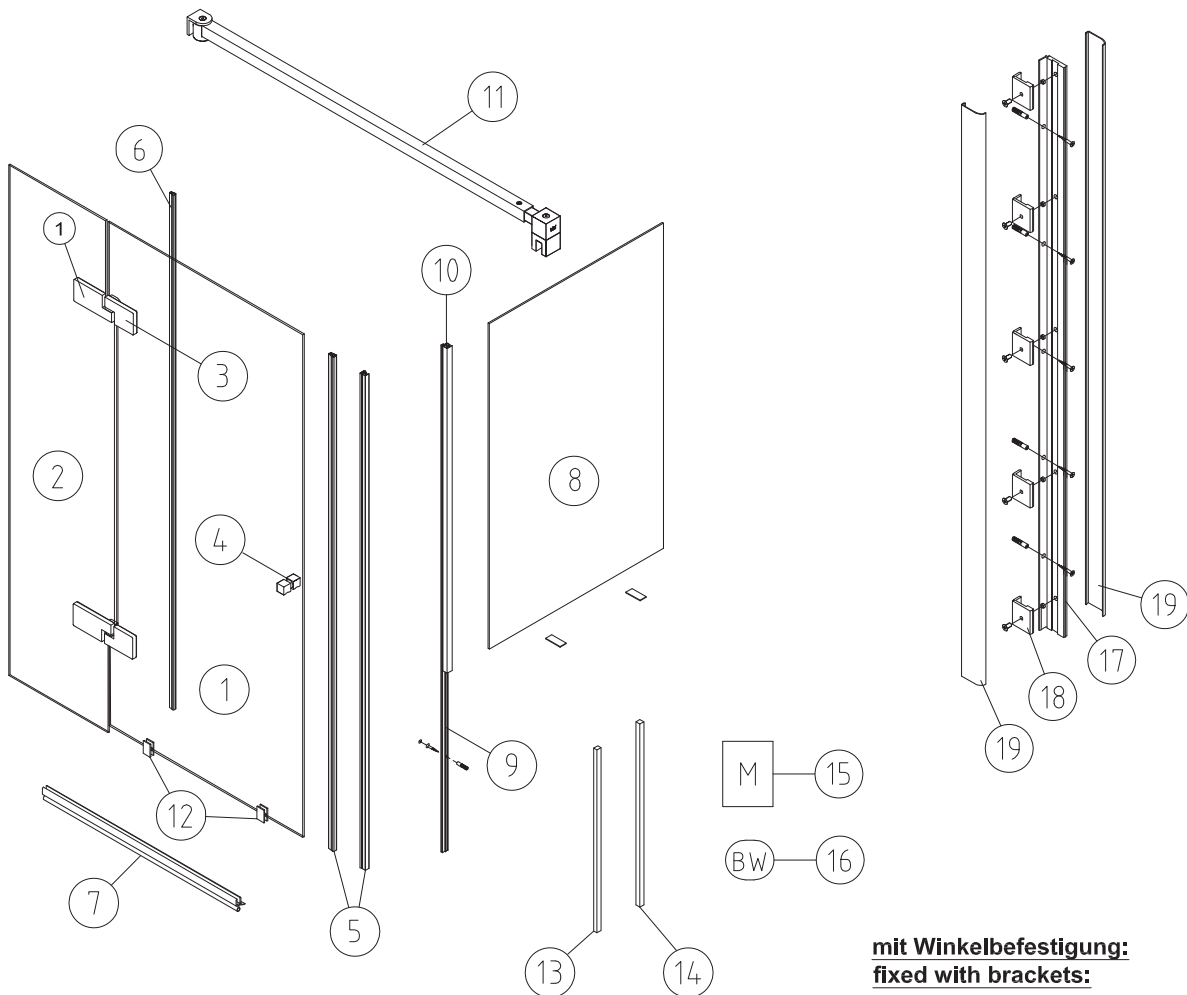

mit Winkelbefestigung:
fixed with brackets:

Material

- | | |
|--|---|
| ① Glas Drehtür (optional) / glass swing door (optional) | 1 |
| ② Glas Fixteil (optional) / glass in-line panel (optional) | 1 |
| ③ Band Glas/Glas / hinge glass/glass | 2 |
| ④ Türkнопf / door knob | 1 |
| ⑤ Pendelmagnetdichtung 90° / magnetic seal 90° for double-action doors | 1 |
| ⑥ Schlauchdichtung Lagerlänge / soft nose seal stock length | 1 |
| ⑦ Wasserabweiser / water disperser | 1 |
| ⑧ Glas Seitenteil (optional) / glass side panel (optional) | 1 |
| ⑨ Magneteleistenträger / magnetic support profile | 1 |
| ⑩ Badewannenaufsatzprofil / bathtub attachment profile | 1 |
| ⑪ Haltestange / support bar | 1 |
| ⑫ Montagehilfen / assembly blocks | 2 |
| ⑬ Vierkant 5x8 mm / square profile 5x8 mm | 1 |
| ⑭ Vierkant 5x5 mm / square profile 5x5 mm | 1 |
| ⑮ Montageanleitung / assembly instruction | 1 |
| ⑯ Beipack Wandbefestigung / fixtures enclosed | 1 |

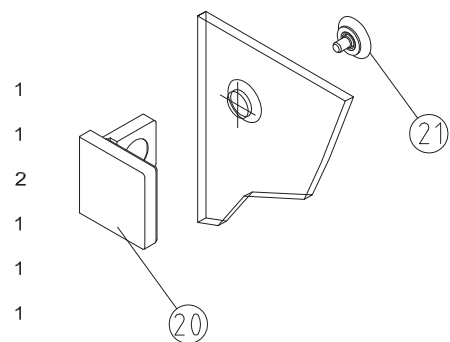

Profilbefestigung / fixed with profiles

- | | |
|-------------------------------|---|
| ⑰ Klemmprofil / clamp profile | 1 |
| ⑱ Klemmstücke / clamps | 5 |
| ⑲ Clipsprofil / clips profile | 2 |

oder / or

Winkelbefestigung / fixed with brackets

- | | |
|-----------------------------------|---|
| ⑳ Winkel G/W / bracket glass/wall | 2 |
| ㉑ Versenk / countersink | 2 |

Einbausituation Profilbefestigung:
Mounting arrangement fixed with profile:

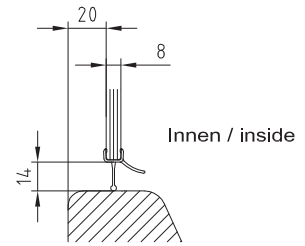
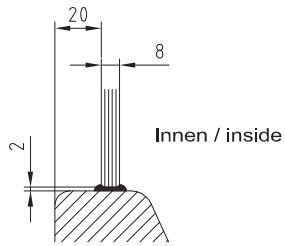
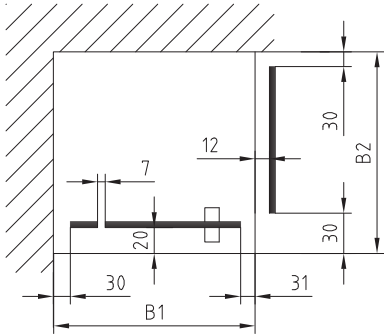

Einbausituation Winkelbefestigung:
Mounting arrangement fixed with brackets:

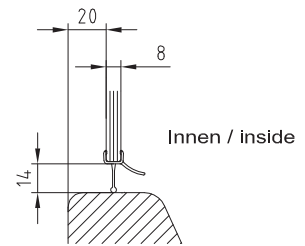
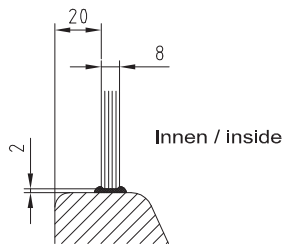
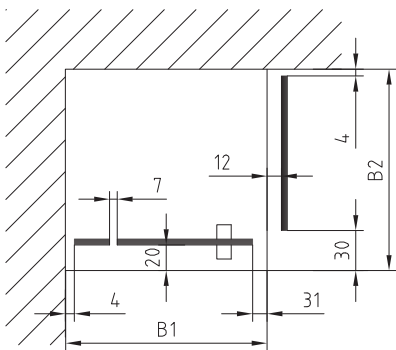

1A

Winkelbefestigung / fixed with brackets

Winkel Glas/Wand an Fixteil und Seitenteil schrauben.

Screw on brackets glass/wall onto in-line and side panel.

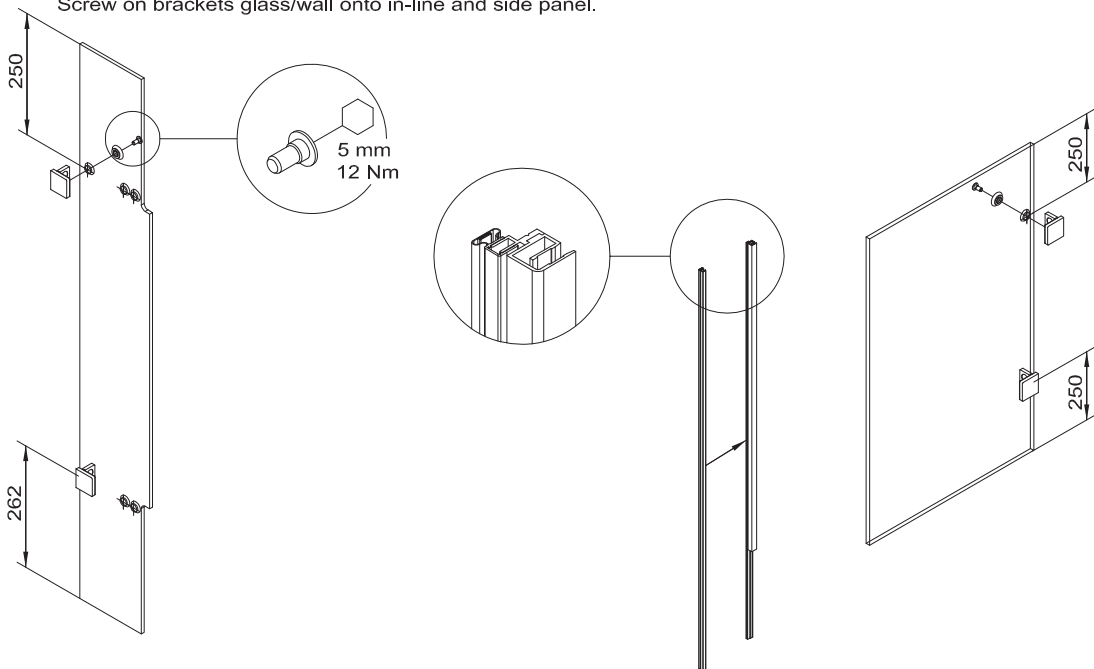

2A

PVC-Streifen zur Distanzhaltung unterlegen.

Fixteil und Seitenteil ausrichten, anzeichnen, bohren und verschrauben.

Place the plastic-strips under the glass to hold the distance.
Adjust in-line and side panel, mark, drill and screw on.

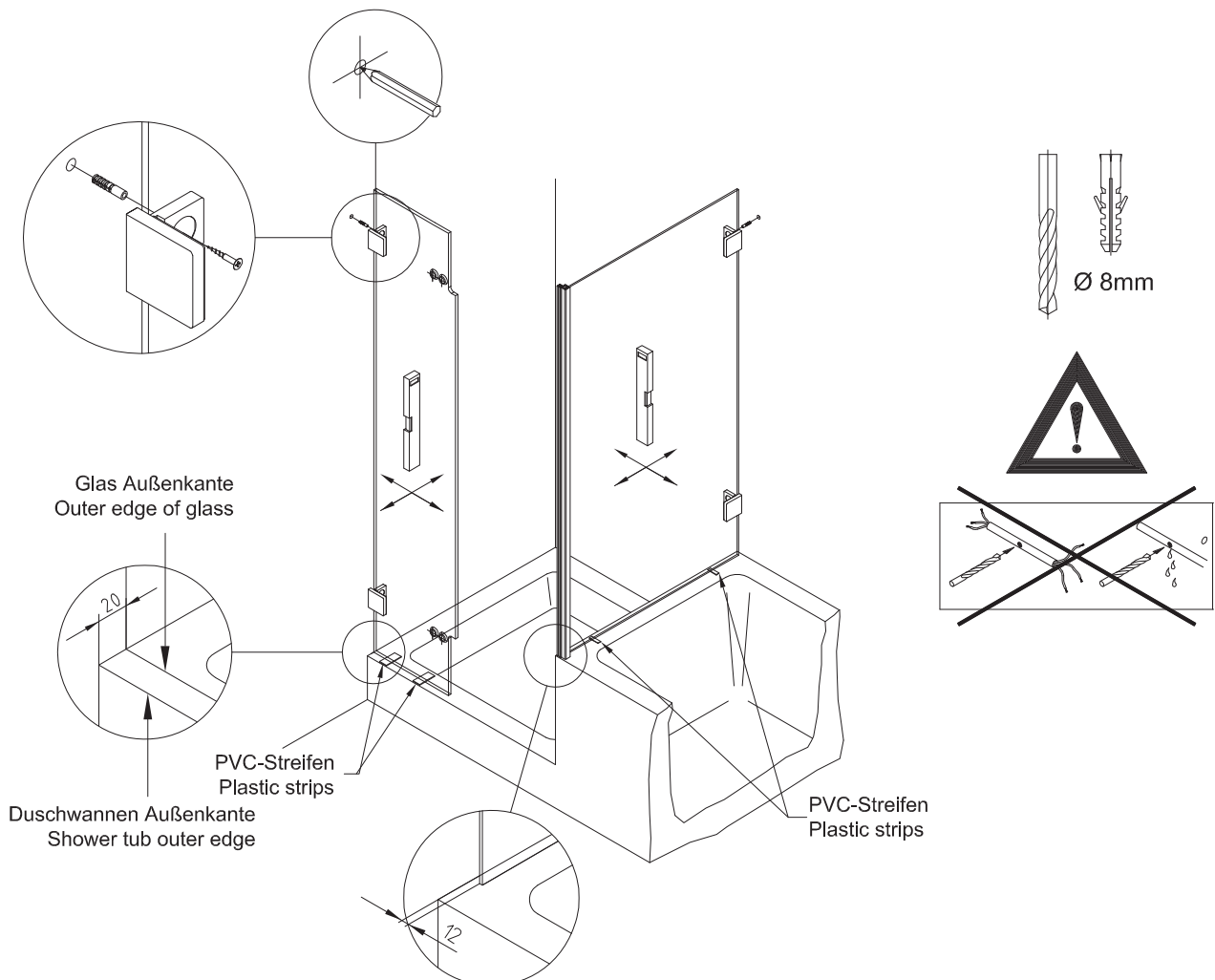

1B

Profillbefestigung / fixed with profile

Klemmprofile ausrichten und Bohrungen anzeichnen.
Löcher bohren und Klemmprofile anschrauben.

Set up clamp profiles and mark the drill holes.
Drill holes and fix the clamp profiles.

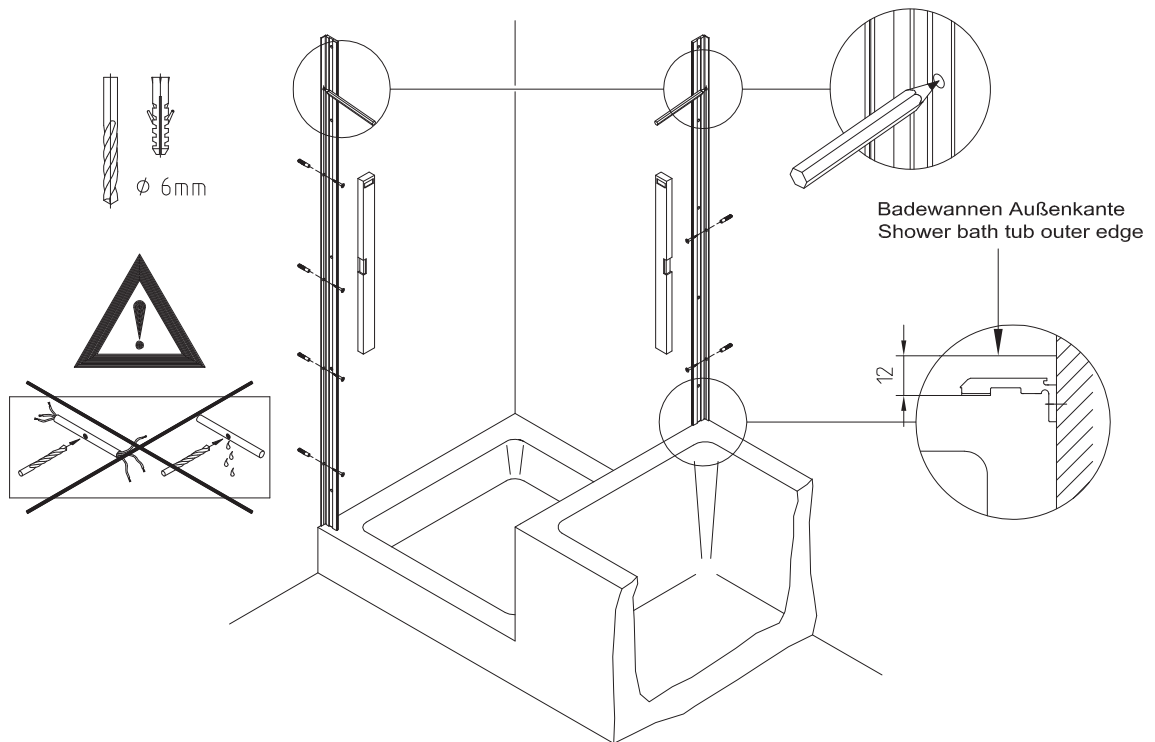

2B

PVC-Streifen zur Distanzhaltung unterlegen.
Fixteil und Seitenteil ausrichten und Klemmstücke anschrauben.

Place the plastic-strips under the glass to hold the distance.
Adjust in-line and side panel and screw on the clamps.

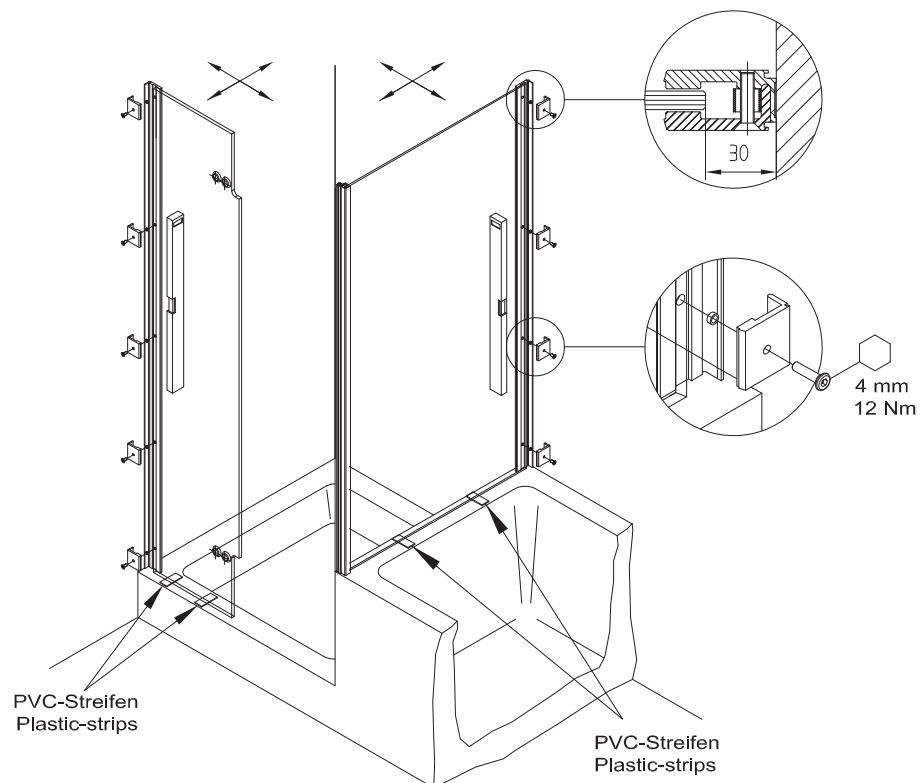

3

Montage des Magneteleistenträgers.
Installation of magnetic support profile.

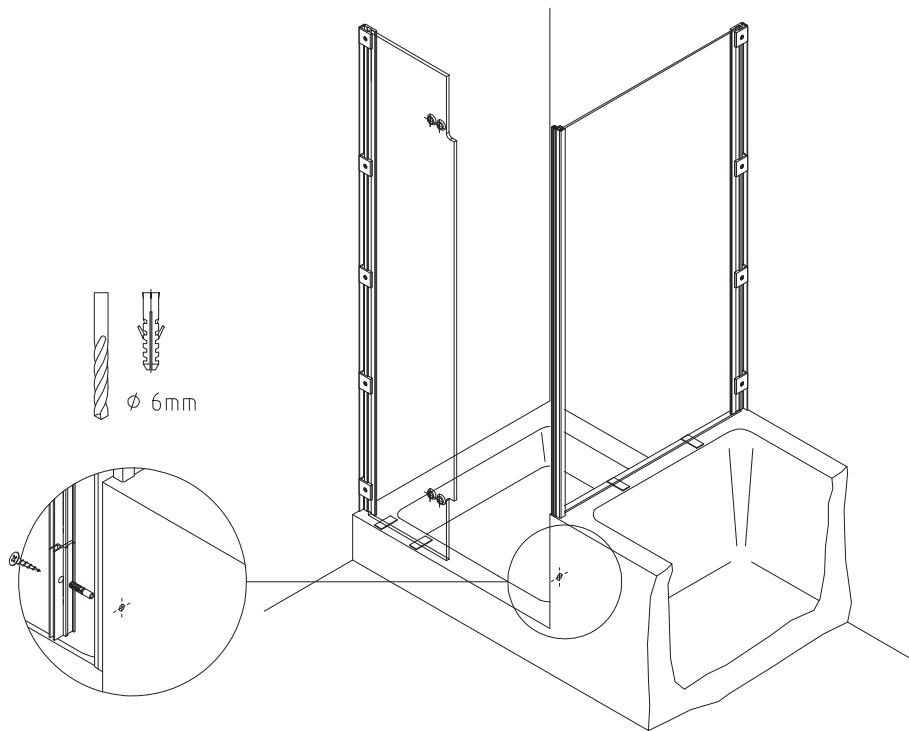

3

Rahmenteil des oberen Beschlags an das Fixteil schrauben.
Screw on frame part of top hinge onto in-line panel.

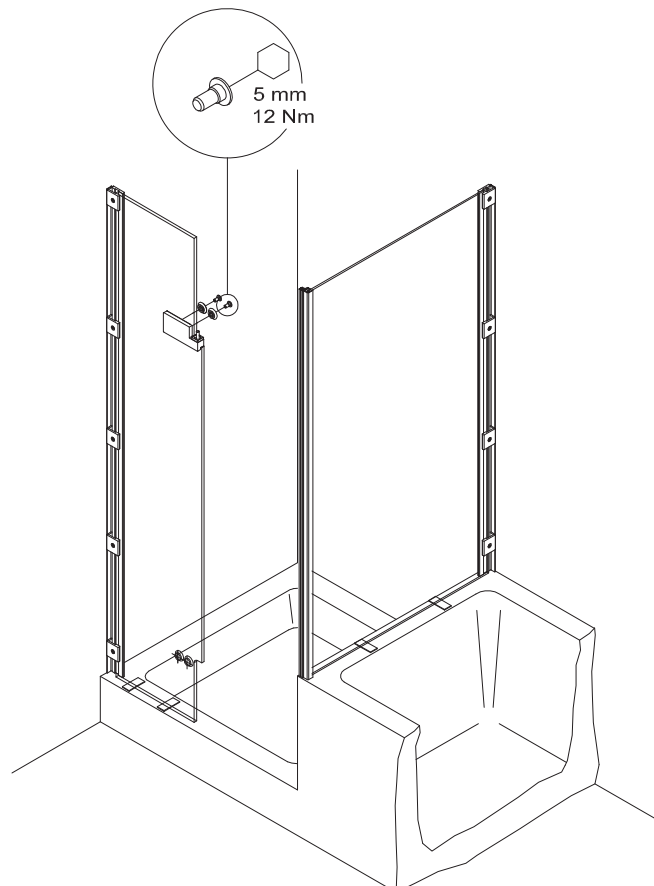

4

Unteren Beschlag in Originalverpackung leicht an das Fixteil schrauben.

Bottom hinge, with original packaging, is to be loosely attached to the in-line panel.

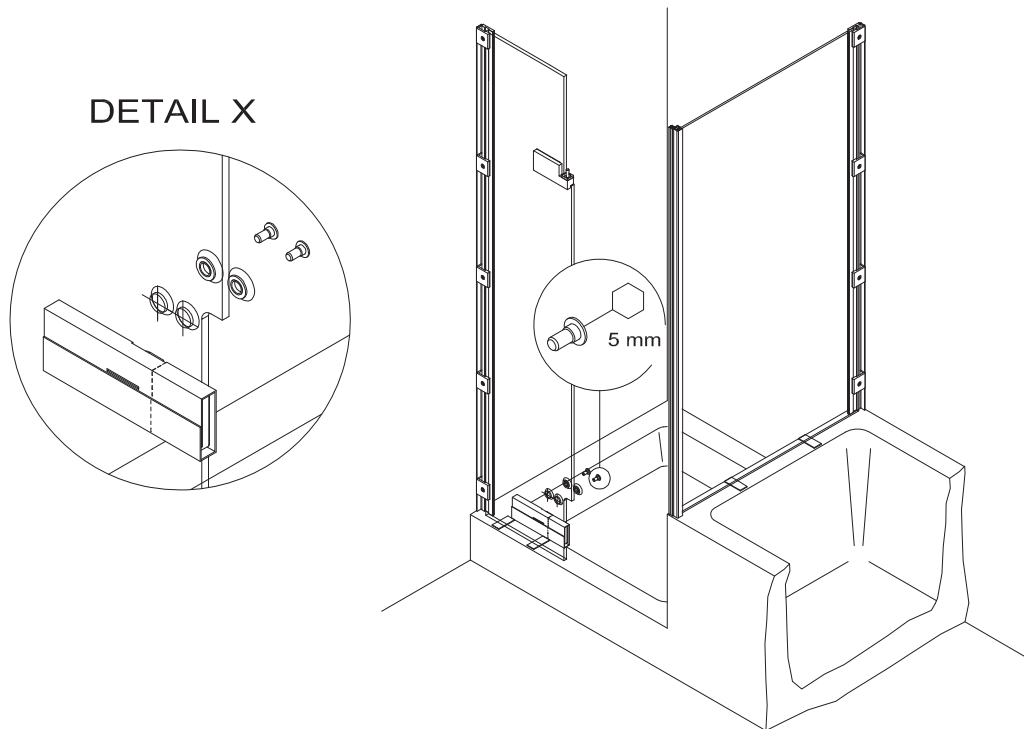

5

Flügelteil des oberen Beschlags an die Drehtür schrauben.
Montagehilfen aufstecken.

Screw on leaf part of top hinges onto swing door.
Attach the assembly blocks.

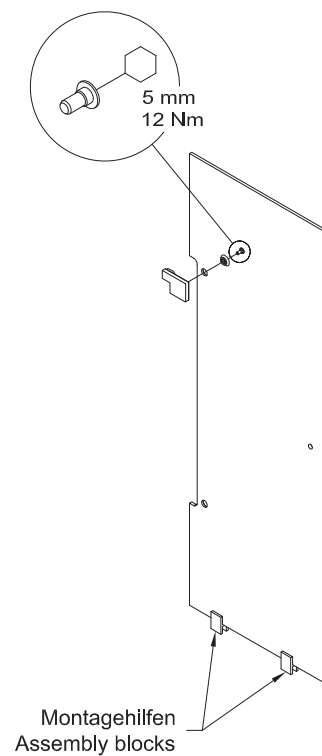

- 6** Glas Drehtür vorsichtig einhängen.
Fit the swing door carefully.

 Glaskanten schützen!
Protect the glass edges!

DETAIL X

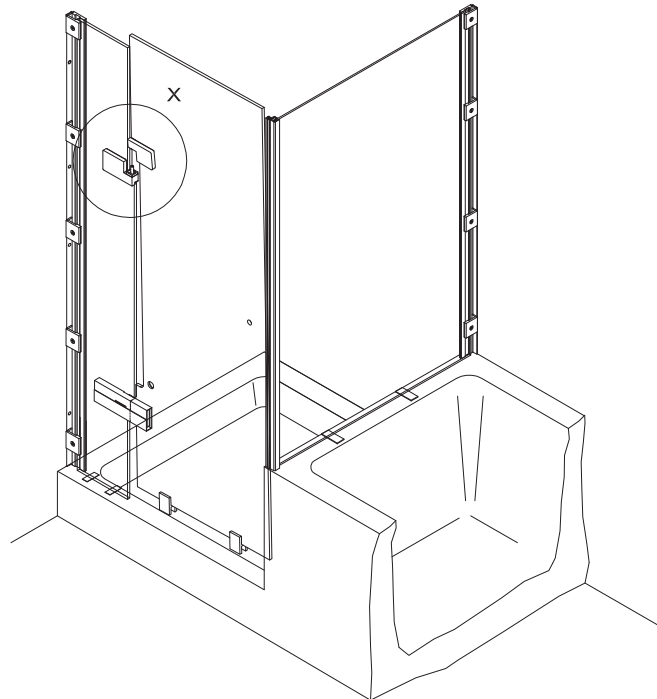
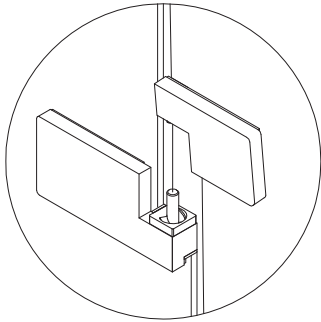

- 7** Unteren Beschlag in Originalverpackung leicht an die Drehtür schrauben.
Bottom hinge, with original packaging, is to be loosely attached to the glass swing door.

DETAIL X

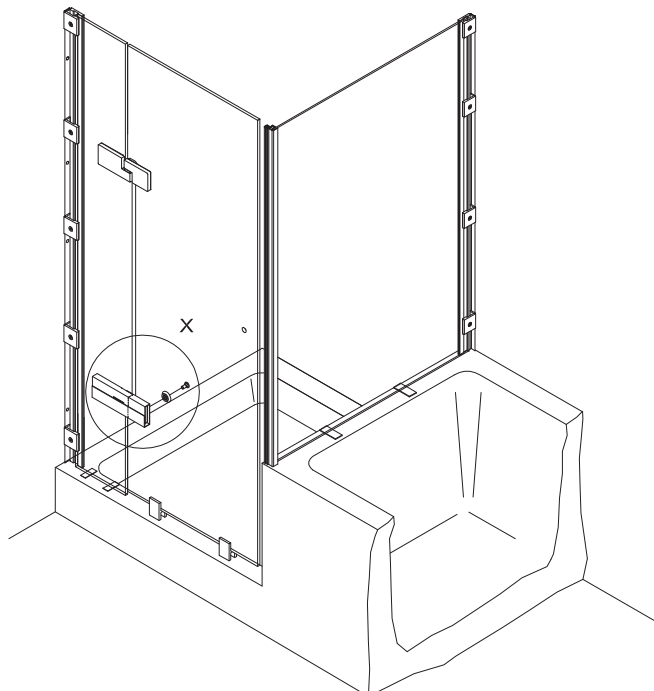
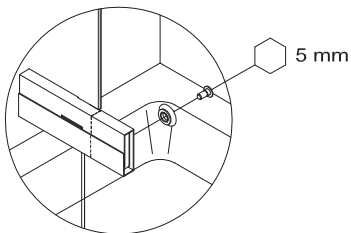

- 8** Originalverpackung am unteren Beschlag entfernen.
Remove the original packaging at bottom hinge.

DETAIL X

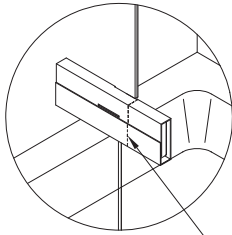

Verpackung an der Perforierung einreißen!
Rip paper packaging along perforated line!

DETAIL X

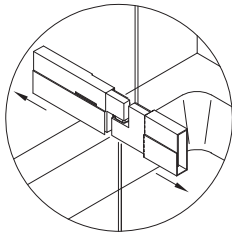

Hälften vorsichtig trennen!
Separate both segments carefully!

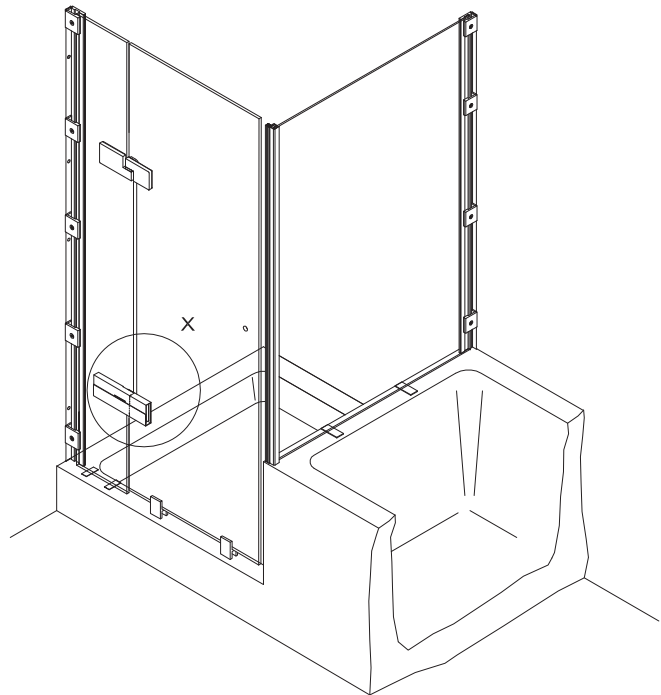

- 9** Glas Drehtür ausrichten und Schrauben anziehen.
Adjust the glass swing door and tighten hinge screws.

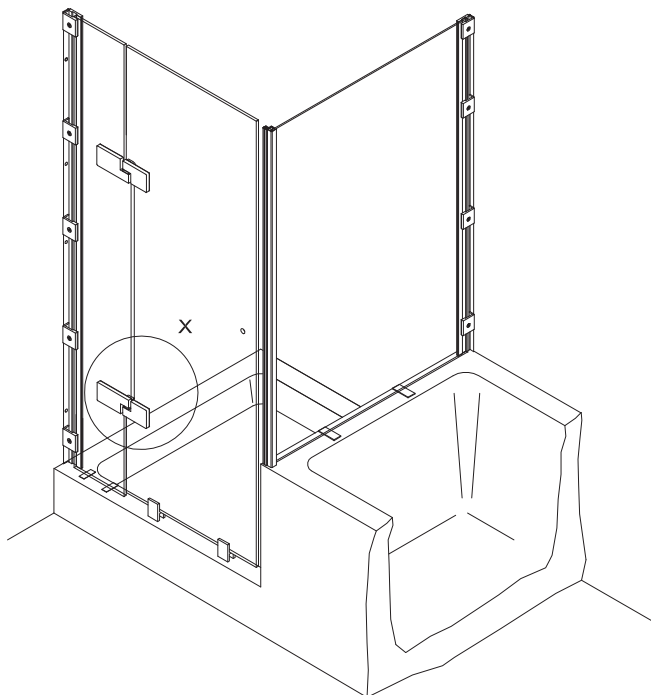

DETAIL X

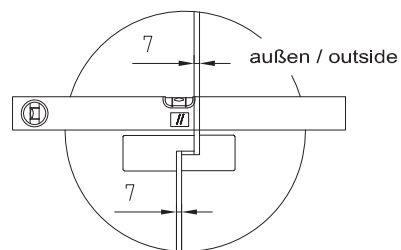

DETAIL X

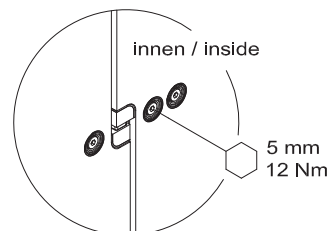

10

Magnetdichtungen aufstecken.
Attach the magnetic seals.

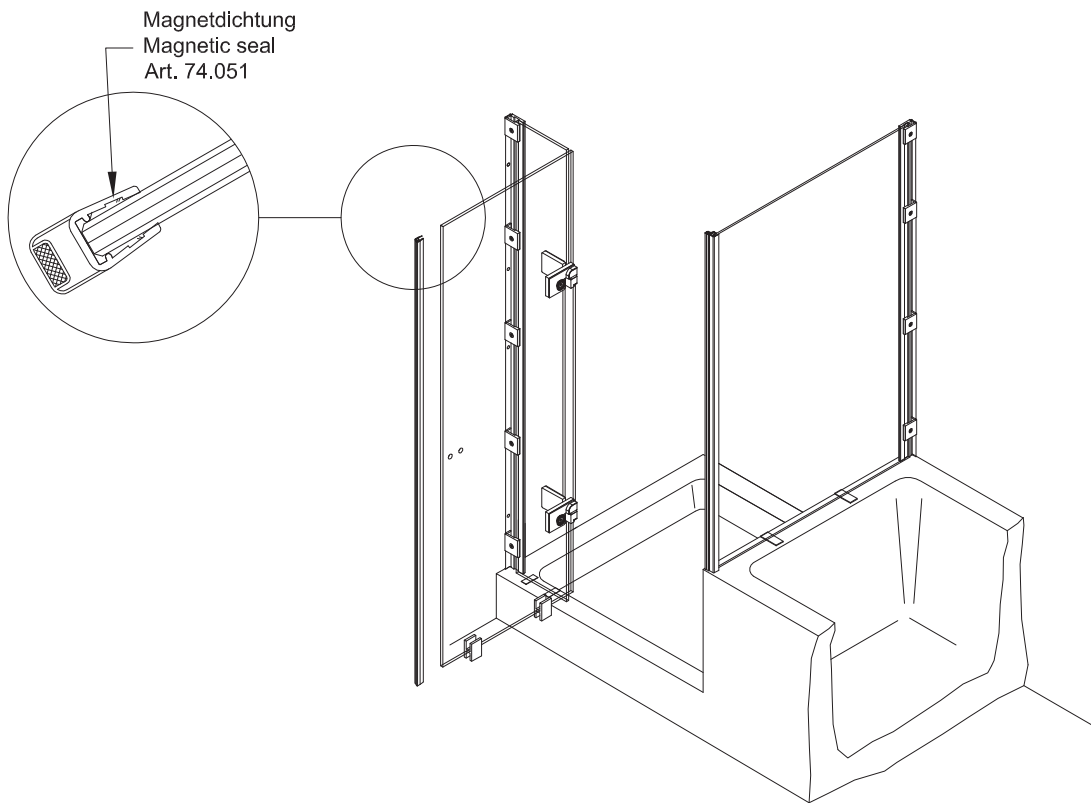

11

Obere und untere Dichtungen einpassen und auf das Fixteil aufstecken.
Conform the top and bottom seals with glass and attach onto in-line panel.

Ausschnitt / cut out

Ansicht von innen / view from the inside

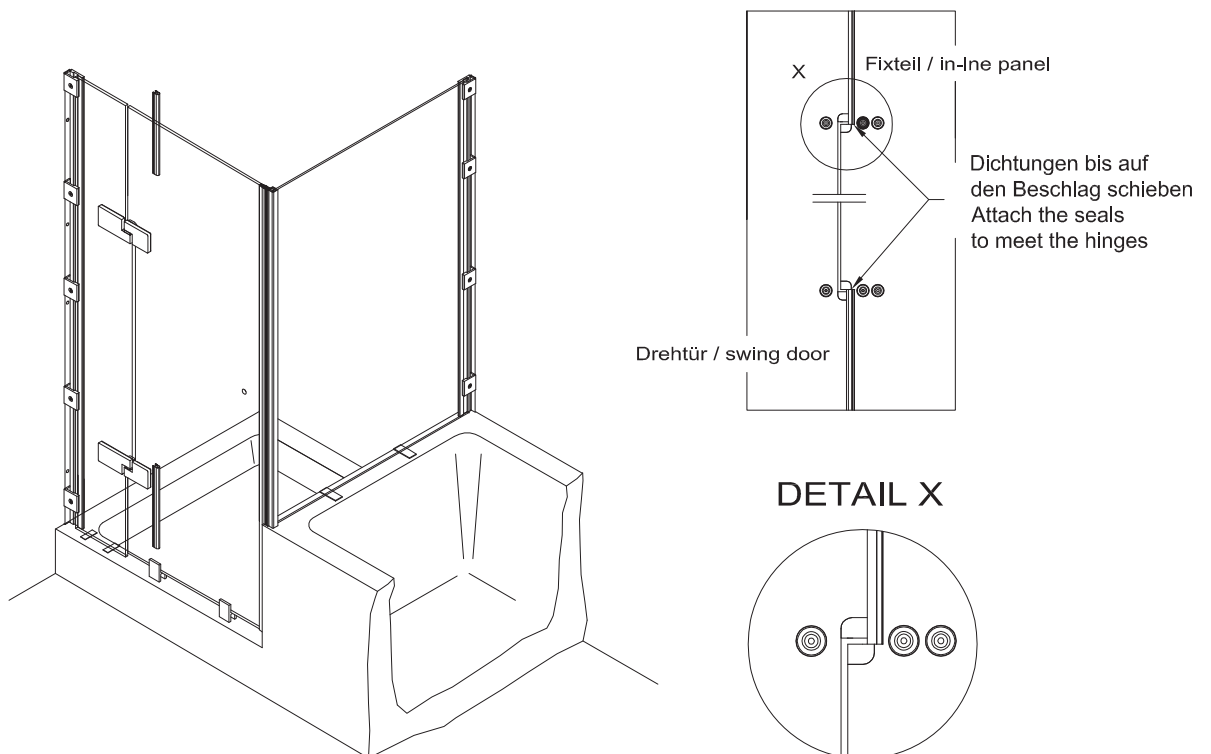

- 12** Mittlere Dichtung einpassen und auf die Drehtüre aufstecken.
Conform the middle seal with glass and attach onto swing door.

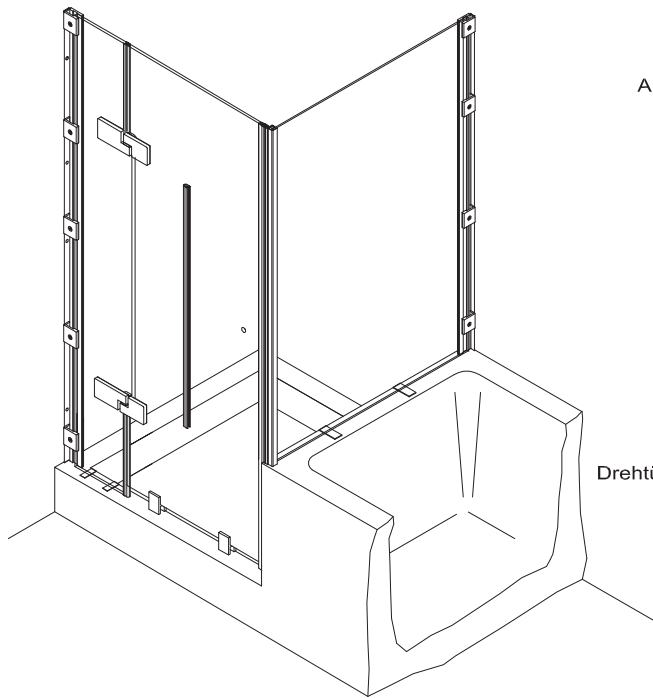

Ausschnitt / cut out
Ansicht von innen / view from the inside

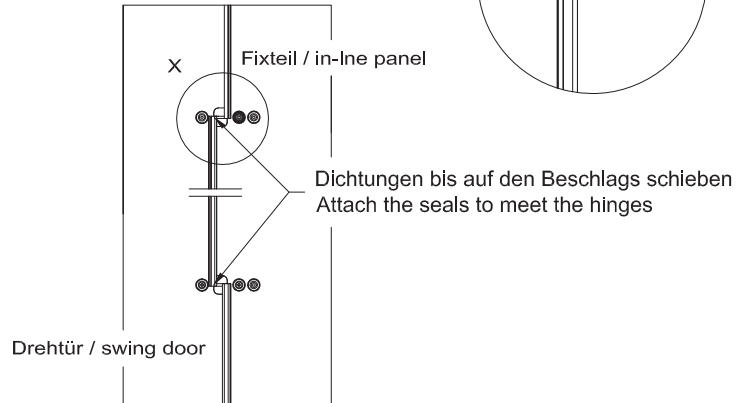

DETAIL X

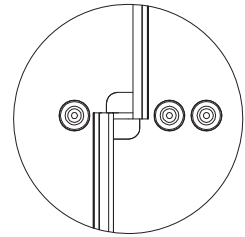

- 13** Türgriffe montieren.
Assembly of door handles.

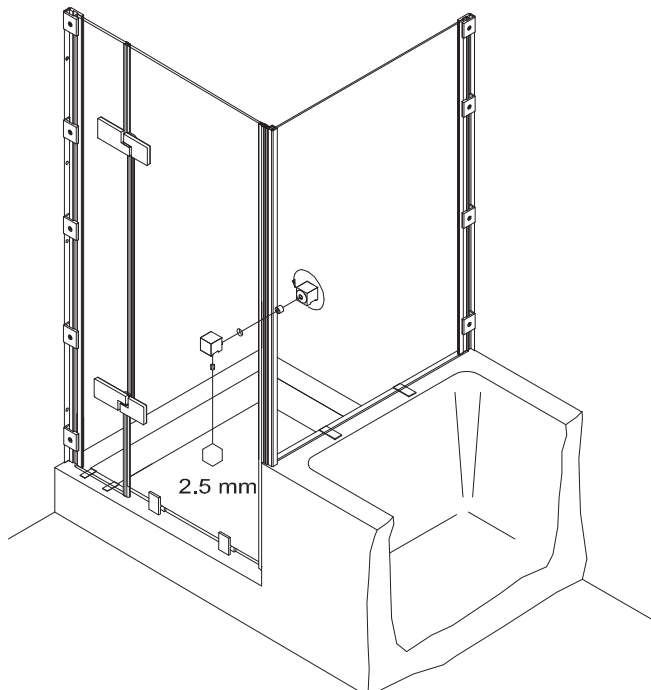

14

1. PVC-Streifen vorsichtig kürzen.
2. Clips Profile aufstecken.
3. Montagehilfen entfernen. Wasserabweiser anpassen und aufstecken.
4. Fixteil, Seitenteil und Clipsprofile versiegeln.
5. Abdeckkappen einclippen.

1. Shorten plastic strips carefully.
2. Put on clips profiles.
3. Remove the assembly blocks. Conform and attach the water disperser.
4. Seal up in-line-, side panel and clips profiles.
5. Clip the cover caps.



Montage der Haltestange gemäß
beiliegender Montageanleitung!



Installation of support bar according
to installation instruction enclosed!

Profilbefestigung
Fixed with profiles

Winkelbefestigung
Fixed with brackets

