

DUSCHSYSTEME
SHOWER SYSTEMS

PROGRAMMÜBERSICHT
PROGRAM OVERVIEW

2026



Philosophie	Philosophy	4	Produktzertifizierung	Product certification	58
Duschsysteme	Shower systems	6	Ausstellungsmodule	Demonstration modules	60
Sonderlösungen	Special solutions	34	Funktionsübersicht	Overview of functions	62
Saunalösungen	Sauna solutions	38	Einbausituationen	Installation situations	64
Black Line	Black Line	40	E-Commerce	E-Commerce	70
Sonderoberflächen	Special surfaces	42	Seminarprogramm	Training Programm	71
Zubehör & Details	Accessories & Details	44			

Erleben Sie gral Duschsysteme Experience gral shower systems

Besuchen Sie unseren Showroom in Rietberg

gral Duschsysteme können Sie in unserer großen Ausstellung im ostwestfälischen Rietberg live erleben – in verschiedenen Ambientes, in vielfältigen Einbausituationen und in der Kombination mit diversen Glasdesigns.

Lassen Sie sich inspirieren – vereinbaren Sie bitte einen Besuchstermin unter Telefon +49 (0) 5244 90 76-0.

Come and visit our showroom in Rietberg, Germany

gral shower systems can be seen at first hand in our showroom in Rietberg in the north-west of Germany. They are displayed in various environments and installation situations, as well as in combination with a wide range of glass designs.

Discover inspiration. Simply phone us to arrange a time to visit: +49 (0) 5244 90 76-0.

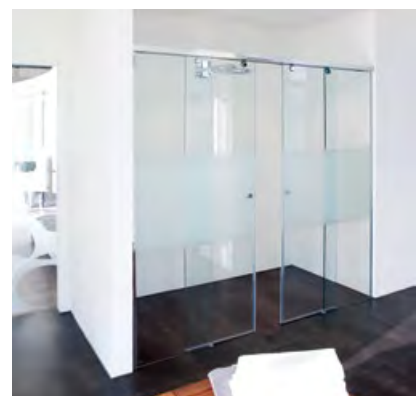

Wertigkeit, die den Unterschied macht

Making a difference through added value



Erstklassige Produkt- und Verarbeitungsqualität

Produkte von gral stehen für deutsche Wertarbeit mit der Garantie auf eine lange Lebenszeit. Hochqualifizierte manuelle Fertigungstechniken und Hightech-Verfahren wie CNC Fräsen/Drehen gehen dabei Hand in Hand.

First-class product quality and workmanship

Products from gral epitomize German craftsmanship with the guarantee of long service lifetimes. Exceptional manual production skills interlink with high-tech processes such as CNC milling/turning.



Hochwertige Beschläge aus massivem Messing

Die Grundlage für die hochwertige Oberflächengüte der gral Produkte bildet massives Messing, dessen mechanische Stabilität die hervorragenden Funktionen der Befestigungssysteme sichert.

High-quality fittings of solid brass

Providing the basis for the high-quality finish common to all gral products, solid brass exhibits the mechanical stability to ensure supreme assembly functionality.



Innovativ konzipierte Beschlagssysteme

Neue Montage-/Befestigungsmethoden, etwa die einfach einzuhängende und einstellbare SF 740 Schiebetür (siehe Foto), weisen wie die einheitliche Designverbund-Serie 112 (BF/BO/BH) für unterschiedliche Funktionen den Weg in die nächste Produktgeneration.

Innovative fittings and accessories

New mounting/fixing techniques, as applied to the easy-to-hang and adjust SF 740 sliding door (see photo), and the advent of the integrated design series 112 (BF/BO/BH), are in the vanguard of our next-generation product solutions for a wide range of applications and functions.

Von der Idee bis hin zur Konzeption – Seit 30 Jahren entwickelt, produziert und vertreibt das Unternehmen aus Rietberg technologisch, qualitativ und ästhetisch herausragende Beschläge und Systeme für Duschtrennungen und Duschkabinen für zeitgemäße Bäder anspruchsvoller Ein- und Mehrfamilienhäuser, Wohnanlagen, Hotels und Kliniken.

From the idea to the conception – For 30 years the company, now based in Rietberg, has been developing, producing and selling technologically, qualitatively and aesthetically outstanding fittings and systems for shower enclosures and cubicles for modern bathrooms in sophisticated single and multiple family homes, residential complexes, hotels and clinics.



Außergewöhnliche Vielfalt an Oberflächen »Colour Edition«

Egal, ob glänzend oder matt, poliert oder unpoliert (antik), farbeschichtet oder sondereloxiert, gral bietet Sonderoberflächen für jeden Einrichtungsstil.

Exceptional choice of surfaces »Colour Edition«

Whether bright or satinized, polished or matt (antique look), color-coated or custom-anodized, gral offers special surfaces to suit any interior style.

Montagefreundlich und langlebig

Leicht verständliche Montageanleitungen und eine 6-jährige Garantie stehen für mühelosen Einbau und lange Benutzerfreude.

Easy to install and thoroughly durable

Readily comprehensible mounting instructions and a 6-year warranty for peace of mind.

Design-Auszeichnung Duscheschlagserie BF 112

Die Pendeltürserie BF 112 ist u. a. für Design, Funktionalität, Ergonomie und Innovationsgrad mit dem reddot Award ausgezeichnet worden.

Design award shower fitting series BF 112

The double-action door serie BF 112 received the reddot Award for their design, functionality, ergonomic efficiency and innovative content.



6 JAHRE GARANTIE
YEARS WARRANTY
** long life product **



Keine Dusche ist wie die andere

Die individuellen Wünsche an die richtige Dusche sind so vielfältig wie die baulichen Voraussetzungen im Bad. Mit der großen Auswahl an Funktionsbeschlägen von gral lässt sich praktisch jede persönliche Traumdusche verwirklichen – ob mit Hebe- / Senk- oder Pendelmechanik, als Schiebetür, Anschlagtür, falt- oder Walk-In Lösung, punktgehalten oder geklemmt.

Every shower is different

Individual requirements for the ideal shower are as diverse as the layouts of bathrooms themselves. With the wide range of gral functional fittings, almost any dream shower can be realized – whether with a rising or double-action mechanism, sliding or swing door, single-point fixing or clamp fittings, or as a folding-door or walk-in solution.

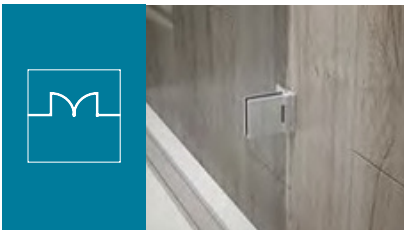

ANSCHLAGTÜRSYSTEME
SINGLE-ACTION DOOR SYSTEMS

8



BO 112 BO 410 BO 415



ANSCHLAGTÜRSYSTEME MIT HEBE-SENK-FUNKTION
SINGLE-ACTION DOOR SYSTEMS WITH LIFT-LOWER-FUNKTION

12



BH 112 BH 200 BH 205 BH 250 BH 255



PENDELTÜRSYSTEME
DOUBLE-ACTION DOOR SYSTEMS

16



Paro Opalea BF 112 BF 112 XL BF 134



SYSTEME MIT GLAS - PONTOS **NEU**
GLASS SYSTEMS - PONTOS

20



Pontos Pendel Pontos Falten



Glasstärke
Glass thickness



einstellbare Nullstellung
adjustable zero positioning



max. Tragfähigkeit (2 Bänder)
max. loading capacity (2 hinges)



Soft-Stop
Soft-Stop



Glasbefestigung mit Gegenplatte
Glass fixing with counterplate



Soft-Einzug
Soft-Closing



Glasbefestigung flächenbündig
Countersunk glass fixing



Sauna geeignet bis 90°
Sauna suitable 90 degrees



FALTTÜRSYSTEME
FOLDING DOOR SYSTEMS

22



BF 112



BF 112 XL



BF 134



SCHIEBETÜRSYSTEME
SLIDING DOOR SYSTEMS

26



SO 730

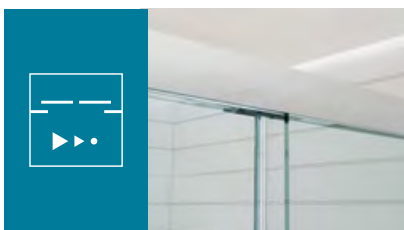

SCHIEBETÜRSYST. MIT DÄMPFUNGS- UND EINZUGSFUNKTION
SLIDING DOOR SYS. WITH DAMPING AND SELF-CLOSING FUNCTION

28

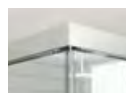

SF 740
PREMIUM



WALK-IN SYSTEME
WALK-IN SYSTEMS

30



WINKEL
BRACKET



PROFIL
PROFILE



SO 730



SF 740
PREMIUM

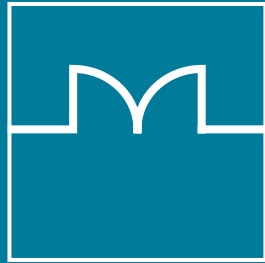

ANSCHLAGTÜRSYSTEME SINGLE-ACTION DOOR SYSTEMS



Der Klassiker unter den Duschsystemen. Anschlagtürsysteme mit Glas/Wand- oder Glas/Glas Beschlägen ohne Zusatzfunktion finden größtenteils Anwendung bei Glasduschen mit Duschtasse in normalgroßen Badezimmern, wo die Flügeltüren problemlos ausschließlich einseitig nach außen geöffnet werden können.

The classic among shower systems. Hinged door systems with glass/wall or glass/glass fittings without additional function are mainly used for glass showers with shower tray in normal sized bathrooms, where the hinged doors can be opened outwards on one side only without any problems.

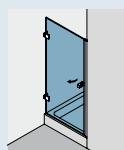

100

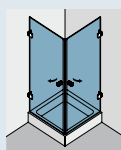

120

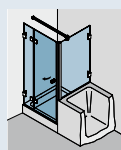

231W/P

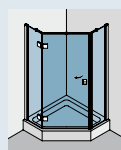

255W/P

Hier sehen Sie nur eine kleine Auswahl möglicher Einbauvarianten. Alle mit dem System realisierbaren Einbausituationen finden Sie ab Seite 64.

Here are a few installation examples. All realizable system installation situations see from page 64.

BO 112

Anschlagtürsystem

- nach außen öffnend
- durchgehende Dichtungen an allen Glaskanten
- Verschraubungen verdeckt
- vielfältige Varianten

Single-action door system

- outward opening
- continuous seals along all glass edges
- concealed screw connections
- wide range of fittings



1



2



3

1 Band Glas/Wand
hinge glass/wall

2 Band Glas/Wand (innen)
hinge glass/wall (inside)

3 Band Glas/Glas 180°
hinge glass/glass 180°





BO 410

Anschlagtürsystem

- nach außen öffnend
- durchgehende Dichtungen an allen Glaskanten
- Verschraubungen verdeckt
- vielfältige Varianten

Single-action door system

- outward opening
- continuous seals along all glass edges
- concealed screw connections
- wide range of fittings



1



2



3

1 Band Glas/Wand
hinge glass/wall

2 Band Glas/Glas 180°
hinge glass/glass 180°

3 Band Glas/Glas 180° (innen)
hinge glass/glass 180° (inside)

BO 415

Anschlagtürsystem

- nach außen öffnend
- durchgehende Dichtungen an allen Glaskanten
- Verschraubungen verdeckt
- vielfältige Varianten

Single-action door system

- outward opening
- continuous seals along all glass edges
- concealed screw connections
- wide range of fittings



1



2



3

1 Band Glas/Wand
hinge glass/wall

2 Band Glas/Glas 180°
hinge glass/glass 180°

3 flächenbündige Glasbefestigung
countersunk glass fixing



BO 410 Typ(e) 130W

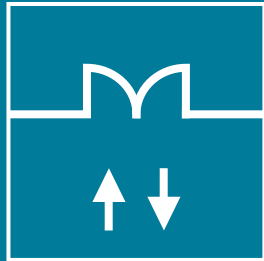

ANSCHLAGTÜRSYSTEME MIT HEBE-SENK-FUNKTION SINGLE-ACTION DOOR SYSTEMS WITH LIFT-LOWER-FUNKTION

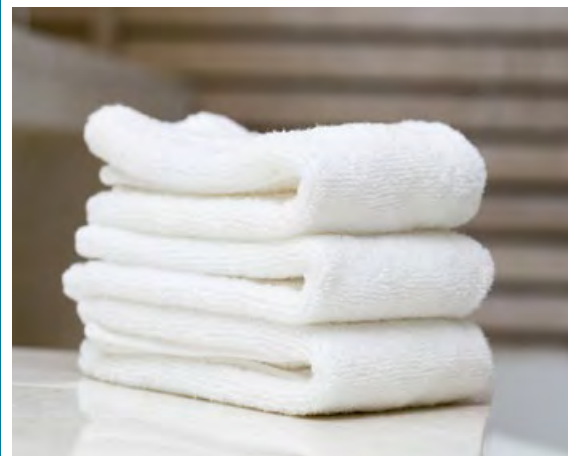

Anschlagtürsysteme mit Hebe-Senk-Funktion sind bestens für barrierefreie, bodeneben begehbare Glasduschen geeignet, die bei Bauherren und Architekten hoch im Kurs stehen. Die stabilen Beschläge heben die Türen beim Öffnen um einige Millimeter an – die unteren Dichtungen werden geschont, da sie dann keinen Bodenkontakt haben.

Hinged door systems with a lift-lower function are ideally suited for barrier-free glass showers that can be walked on at floor level, which are very popular with building owners and architects. The stable fittings lift the door(s) by a few millimeters when opened – the lower seals are protected as they then have no contact with the floor.

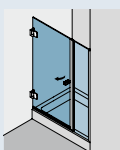

110W/P

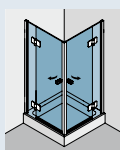

220W/P

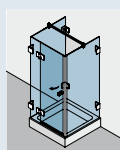

233W/P

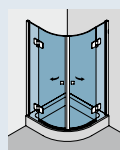

260W/P

Hier sehen Sie nur eine kleine Auswahl möglicher Einbauvarianten. Alle mit dem System realisierbaren Einbausituationen finden Sie ab Seite 65.

Here are a few installation examples. All realizable system installation situations see from page 65.

BH 112

Anschlagtürsystem

- nach außen öffnend
- Hebe-Senk (+/-5 mm)
- selbstschließend ab 90°
- durchgehende Dichtungen an allen Glaskanten
- Verschraubungen verdeckt
- vielfältige Varianten

Single-action door system

- outward opening
- lift-lower (+/-5 mm)
- self-closing from 90°
- continuous seals along all glass edges
- concealed screw connections
- wide range of fittings



1 Band Glas/Wand
hinge glass/wall

2 Band Glas/Wand (innen)
hinge glass/wall (inside)

3 Band Glas/Glas 180°
hinge glass/glass 180°





BH 200

Anschlagtürsystem

- nach außen öffnend
- Hebe-Senk (+/-5 mm)
- selbstschließend ab 90°
- durchgehende Dichtungen an allen Glaskanten
- Verschraubungen verdeckt

Single-action door system

- outward opening
- lift-lower (+/-5 mm)
- self-closing from 90°
- continuous seals along all glass edges
- concealed screw connections



1 Band Glas/Wand
hinge glass/wall

2 Band Glas/Glas 180°
hinge glass/glass 180°

3 Band Glas/Glas 180° (innen)
hinge glass/glass 180° (inside)

BH 205

Anschlagtürsystem

- nach außen öffnend
- Hebe-Senk (+/-5 mm)
- selbstschließend ab 90°
- durchgehende Dichtungen an allen Glaskanten
- Verschraubungen verdeckt

Single-action door system

- outward opening
- lift-lower (+/-5 mm)
- self-closing from 90°
- continuous seals along all glass edges
- concealed screw connections



1 Band Glas/Wand
hinge glass/wall

2 Band Glas/Glas 180°
hinge glass/glass 180°

3 flächenbündige Glasbefestigung
countersunk glass fixing

BH 250

Anschlagtürsystem

- nach außen öffnend
- Hebe-Senk (+/-5 mm)
- selbstschließend ab 90°
- durchgehende Dichtungen an allen Glaskanten
- Verschraubungen verdeckt
- minimalistisch

Single-action door system

- outward opening
- lift-lower (+/-5 mm)
- self-closing from 90°
- continuous seals along all glass edges
- concealed screw connections
- minimalistic



1



2



3

1 Band Glas/Wand
hinge glass/wall

2 Band Glas/Glas 180°
hinge glass/glass 180°

3 flächenbündige Glasbefestigung
countersunk glass fixing

BH 255

Anschlagtürsystem

- nach außen öffnend
- Hebe-Senk (+/-5 mm)
- selbstschließend ab 90°
- durchgehende Dichtungen an allen Glaskanten
- Verschraubungen verdeckt
- minimalistisch

Single-action door system

- outward opening
- lift-lower (+/-5 mm)
- self-closing from 90°
- continuous seals along all glass edges
- concealed screw connections
- minimalistic



1



2



3

1 Band Glas/Wand
hinge glass/wall

2 Band Glas/Glas 180°
hinge glass/glass 180°

3 Band Glas/Glas 180° (innen)
hinge glass/glass 180° (inside)

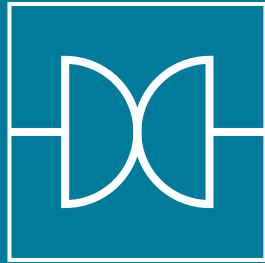

PENDELTÜRSYSTEME DOUBLE-ACTION DOOR SYSTEMS



Glasduschen mit Pendeltüren lassen sich bequem sowohl nach innen als auch nach außen öffnen und ermöglichen so jederzeit einen komfortablen Einstieg. Sie kommen aber nicht nur in großzügig dimensionierten Badezimmern zum Einsatz, sondern auch dort, wo die Raum- oder Duschengröße nur eine Öffnung nach innen erlaubt.

Glass showers with double-action doors can be opened easily both inwards and outwards, allowing easy access at any time. However, they are not only used in generously dimensioned bathrooms, but also where the size of the room or shower only allows an opening to the inside.

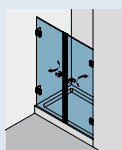

105



110W/P



200W/P

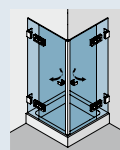

220W/P

Hier sehen Sie nur eine kleine Auswahl möglicher Einbauvarianten. Alle mit dem System realisierbaren Einbausituationen finden Sie ab Seite 66.

Here are a few installation examples. All realizable system installation situations see from page 66.

Paro **NEU**

Pendeltürsystem

- nach innen/außen öffnend
- Glasbefestigung flächenbündig
- Wandbefestigung mit Langloch
- inkl. Anschlagsschutz
- Verschraubungen verdeckt
- Magnetische Wandkappe

Double-action door system

- inward/outward opening
- flush-mounted glass fixing
- Wall fixing with slotted holes
- integrated impact protector
- concealed screw connections
- Magnetic wall cover



1



2



3

1 Winkel Glas/Wand 90°
bracket glass/wall 90°

2 flächenbündige Glasbefestigung
countersunk glass fixing

3 Magnetische Wandkappe
magnetic cover

Opalea **NEU**

Pendeltürsystem

- nach innen/außen öffnend
- Beschläge mit Federmechanismus
- Wandbefestigung mit Langlöchern
- einstellbare Nullstellung
- selbstschließend ab 20°
- Verschraubungen verdeckt

Double-action door system

- inward/outward opening
- door fittings with spring mechanism
- wall fixing with elongated holes
- variable zero positioning
- self-closing from 20°
- concealed screw connections



1



2



3

1 Band Glas/Wand 90°
hinge glass/wall 90°

2 Winkel Glas/Wand 90°
bracket glass/wall 90°

3 Runder Türgriff
rounded door handle



BF 112



Pendeltürsystem

- nach innen/außen öffnend
- Türbeschläge mit Federmechanismus
- einstellbare Nullstellung
- selbstschließend ab 20°
- Verschraubungen verdeckt
- vielfältige Varianten

Double-action door system

- inward/outward opening
- door fittings with spring mechanism
- adjustable zero positioning
- self-closing from 20°
- concealed screw connections
- wide range of fittings

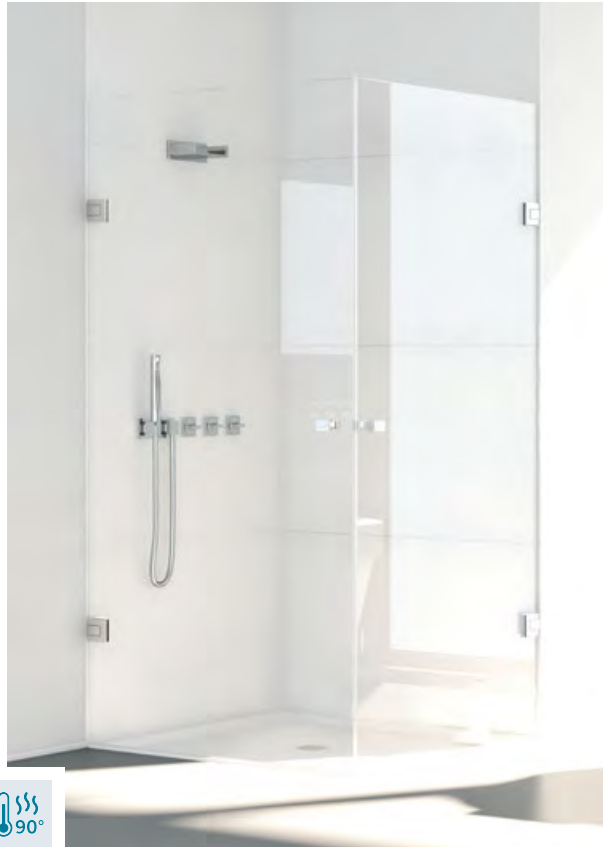

1 Band Glas/Wand
hinge glass/wall

2 Band Glas/Glas 180°
hinge glass/glass 180°

3 Band Glas/Glas 90°
hinge glass/glass 90°

BF 112 XL

Pendeltürsystem

- nach innen/außen öffnend
- Türbeschläge mit Federmechanismus
- für XL-Abmessungen
- einstellbare Nullstellung
- selbstschließend ab 20°
- Verschraubungen verdeckt

Double-action door system

- inward/outward opening
- door fittings with spring mechanism
- for XL-dimensions
- adjustable zero positioning
- self-closing from 20°
- concealed screw connections



1 Band Glas/Wand XL
hinge glass/wall XL

2 Band Glas/Wand XL
hinge glass/wall XL

3 Band Glas/Glas 180° XL
hinge glass/glass 180° XL

BF 134

Pendeltürsystem

- nach innen/außen öffnend
- Türbeschläge mit Federmechanismus
- selbstschließend ab 20°
- vielfältige Varianten
- T-Beschläge für Reihenanlagen (siehe Seite 35)

Double-action door system

- inward/outward opening
- door fittings with spring mechanism
- self-closing from 20°
- wide range of fittings
- T-fittings for in-line cubicles (see page 35)



1 Band Glas/Wand
hinge glass/wall

2 Band Glas/Glas 180°
hinge glass/glass 180°

3 Band Glas/Glas 90°
hinge glass/glass 90°



SYSTEME MIT GLAS - PONTOS
GLASS SYSTEMS - PONTOS



Schnell verfügbar – in 72 Stunden ab Lager
Komplettsysteme mit 6 mm ESG-Glas in
Standardmaßen.

Die teilgerahmten Systeme ermöglichen eine flexible
Nutzung als Pendel- oder Falttür mit Öffnung nach
innen und außen. Ausgestattet mit Hebe-Senk-
Funktion, hochwertigen Beschlägen und
durchdachten Verstellmöglichkeiten bieten sie eine
komfortable Montage und zuverlässige Funktion –
ideal für vielseitige Duschlösungen.

Fast delivery – complete systems with 6 mm
tempered glass in standard sizes available from
stock within 72 hours.

The partially framed systems allow for flexible use
as swing or folding doors that open inward or
outward. Equipped with a lift-and-lower function,
high-quality hinges and well-designed adjustment
options, they offer easy fitting and reliable
function – ideal for a wide range of shower
solutions.

Pontos **NEU**

Pendeltürsystem

- nach innen/außen öffnend
- teilgerahmtes Türsystem
- Hebe-Senk-Funktion ± 5 mm
- max. Türbreite 850 mm
- selbstschließend ab 20°
- Wandbefestigung mit Langlöchern

Double-action door system

- inward/outward opening
- partially framed door system
- lift-and-lower function ± 5 mm
- max. door width 850 mm
- self-closing from 20°
- Wall fixing with slotted holes



1



2



3

1 Patentiertes Klemmprofil
patented clamping profile

2 Hebe-Senk-Funktion ± 5 mm
lifting/lowering function ± 5 mm

3 Runder Türgriff
rounded door handle

Pontos **NEU**

Falлтürsystem

- nach innen/außen öffnend
- Beschläge mit Federmechanismus
- Wandbefestigung mit Langlöchern
- einstellbare Nullstellung
- selbstschließend ab 20°
- Verschraubungen verdeckt

Double-action door system

- inward/outward opening
- door fittings with spring mechanism
- wall fixing with elongated holes
- variable zero positioning
- self-closing from 20°
- concealed screw connections



1



2

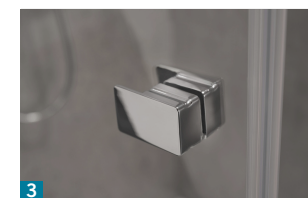

3

1 Band Glas/Glas 180°
hinge glass/Glas 180°

2 Glasbefestigung flächenbündig
countersunk glass fixing

3 Runder Türgriff
rounded door handle



FALTTÜRSYSTEME FOLDING DOOR SYSTEMS



Falлтүrsysteme erlauben selbst in kleineren Bädern einen großzügigen Duscheinstieg. Die beweglichen Glastürflügel lassen sich komplett an die Wand parken und schaffen so einen optimal barrierefreien Zugang zur Dusche. Vorteil: mehr Raumgewinn, mehr Bewegungsfreiheit und eine großzügige Optik auch bei Nichtbenutzung der Dusche.

Folding door systems allow a generous shower entrance even in smaller bathrooms. The movable glass door panels can be parked completely against the wall and thus create optimal barrier-free access to the shower. Advantage: more space, more freedom of movement and a generous appearance even when the shower is not in use.

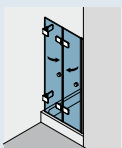

400(ü)

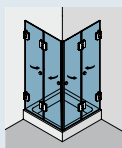

420

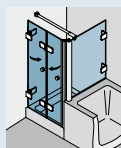

431W(ü)

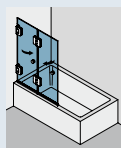

470

Hier sehen Sie nur eine kleine Auswahl möglicher Einbauvarianten. Alle mit dem System realisierbaren Einbausituationen finden Sie ab Seite 68.

Here are a few installation examples. All realizable system installation situations see from page 68.

BF 112

Falt-/Pendeltürsystem

- nach innen/außen öffnend
- großzügiger Duscheinstieg
- Band Glas/Glas ohne Federmechanismus
- Band Glas/Wand mit einstellbarer Nullstellung
- Verschraubungen verdeckt

Folding-/Double-action door system

- inward/outward opening
- wide shower entry
- hinge glass/glass without spring mechanism
- hinge glass/wall with adjustable zero positioning
- concealed screw connections



1 Band Glas/Glas 180°
hinge glass/glass 180°

2 Band Glas/Glas 180° (innen)
hinge glass/glass 180° (inside)

3 auf Badewanne (geöffnet)
on bathtub (open)

BF 112 XL

Falt-/Pendeltürsystem

- nach innen/außen öffnend
- großzügiger Duscheinstieg
- Band Glas/Glas ohne Federmechanismus
- Band Glas/Wand mit einstellbarer Nullstellung
- Verschraubungen verdeckt

Folding-/Double-action door system

- inward/outward opening
- wide shower entry
- hinge glass/glass without spring mechanism
- hinge glass/wall with adjustable zero positioning
- concealed screw connections

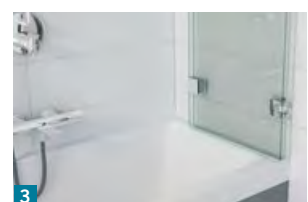

1 Band Glas/Wand
hinge glass/wall

2 Band Glas/Glas 180°
hinge glass/glass 180°

3 auf Badewanne (geöffnet)
on bathtub (open)



BF 134

Falt-/Pendeltürsystem

- nach innen/außen öffnend
- großzügiger Duscheinstieg
- Band Glas/Glas ohne Federmechanismus

Folding-/Double-action door system

- inward/outward opening
- wide shower entry
- hinge glass/glass without spring mechanism

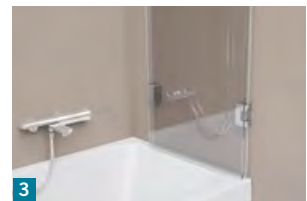

1 Band Glas/Glas 180°
hinge glass/glass 180°

2 Band Glas/Glas 180° (innen)
hinge glass/glass 180° (inside)

3 auf Badewanne (geöffnet)
on bathtub (open)



Bild: © Odenwaldglas

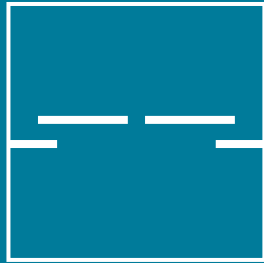

SCHIEBETÜRSYSTEME SLIDING DOOR SYSTEMS



Schiebetürsysteme werden schon immer gerne gewählt, weil sie leicht zu bedienen sind und für den Einstieg auch keine Raumtiefe beanspruchen. So eignen sie sich ideal für kleine Bäder, aber auch für Großraumduschen, im Objektbereich ebenso wie im Privatbad. Diese bedienerfreundlichen Systeme eignen sich auch hervorragend als Badewannenaufsatz.

Sliding door systems have always been a popular choice because they are easy to operate and do not require any room depth for entry. This makes them ideal for small bathrooms, but also for large-capacity showers, in commercial and private bathrooms. These user-friendly systems are also suitable for excellent bathtub attachments.

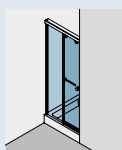

300(ü)

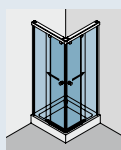

320(ü)

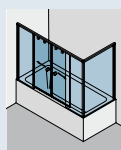

380(ü)BW

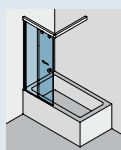

530(ü)BW

Hier sehen Sie nur eine kleine Auswahl möglicher Einbauvarianten. Alle mit dem System realisierbaren Einbausituationen finden Sie ab Seite 68.

Here are a few installation examples. All realizable system installation situations see from page 68.

SO 730

Schiebetürsystem

- sichtbare Laufwagen (mit Glasbearbeitung)
- Glasüberlappung 40 mm
- Wand- und Deckenmontage
- wandseitig auch ohne vertikale Profile (auf Wunsch)

Sliding door system

- visible slide units (with glass preparation)
- overlap, glass elements 40 mm
- wall and ceiling fixing
- sidewall without vertical profiles (upon request)



1



2



3

1 Deckenmontage
ceiling fixing

2 Schiebetürlaufwagen (außen)
sliding door unit (outside)

3 Schiebetürgriff
sliding door knob





SCHIEBETÜRSYSTEME MIT DÄMPFUNGS- UND EINZUGSFUNKTION SLIDING DOOR SYSTEMS WITH DAMPING AND SELF-CLOSING FUNCTION

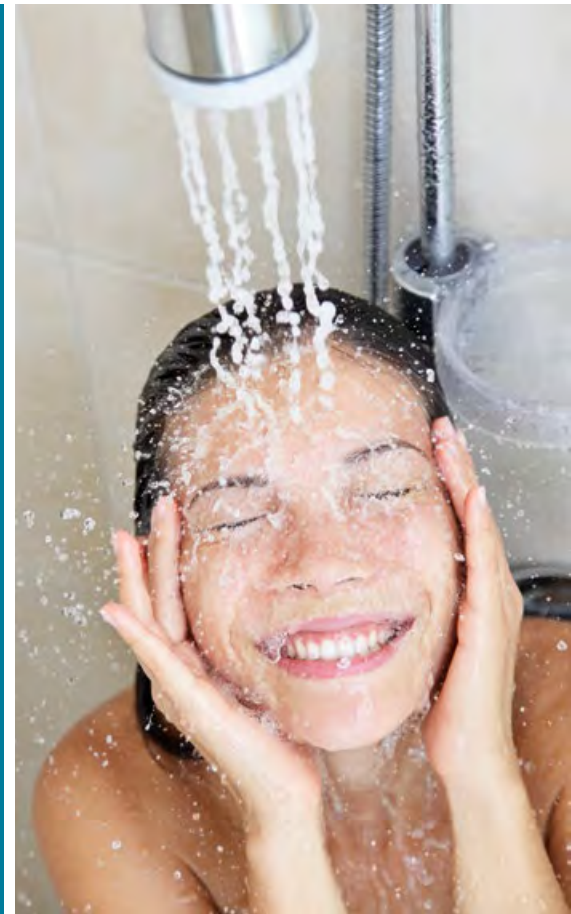

Mit der Dämpfungs- und Einzugsfunktion wird der Bedienkomfort von Schiebetürsystemen weiter gesteigert. Sowohl beim Öffnen als auch beim Schließen werden die Türflügel sanft und leise gebremst; ohne Aufprall und ohne Zurückfedern werden sie in die Endposition eingezogen. Diese bedienerfreundlichen Systeme eignen sich auch hervorragend als Bade- wannenauflage.

The damping and self-closing function further increases the ease of use of sliding door systems. Both when opening and closing, the door panels are quietly and gently braked; without impact and without springing back, they are retracted into the end position. These user-friendly systems are also suitable for excellent bath tub attachments.

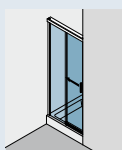

300(ü)

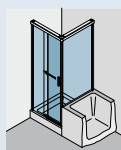

331(ü)

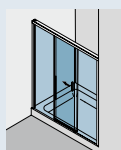

370(ü)

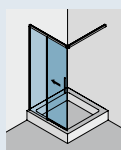

530(ü)DT

Hier sehen Sie nur eine kleine Auswahl möglicher Einbauvarianten. Alle mit dem System realisierbaren Einbausituationen finden Sie ab Seite 68.

Here are a few installation examples. All realizable system installation situations see from page 68.

SF 740 PREMIUM

Schiebetürsystem

- verdeckte Klemmlaufwagen (ohne Glasbearbeitung)
- beidseitige Dämpfung inkl. beidseitiger Einzugsfunktion
- teilbare Bodenführung **3**
- Glasüberlappung 40 mm
- Wand- und Deckenmontage

Sliding door system

- concealed clamp-type carriers (no glass preparation)
- damping and self-closing on both door sides
- separable floor guide **3**
- overlap. glass elements 40 mm
- wall and ceiling fixing

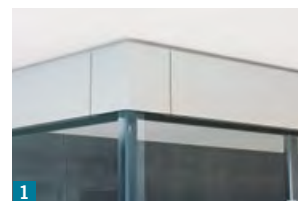

1



2



3

1 Deckenmontage
Ceiling fixing

2 vormontierte Funktionselemente
pre-fitted functional elements

3 einfache Reinigung
easy cleaning





WALK-IN SYSTEME WALK-IN SYSTEMS



Frei begehbare Walk-In-Duschen ohne Tür mit flacher Duschtasse oder bodeneben gefließt, erfreuen sich ob ihrer klaren, zurückhaltenden Wirkung großer Beliebtheit. Großzügig und leicht heben sie die Trennung zwischen Dusche und restlichem Bad auf. Ob als einzelne Trennwand oder als komplexere Überecksituation, der einfache Zugang zur Dusche wird hier besonders geschätzt.

Freely accessible walk-in showers without doors, with a flat shower tray or tiled at floor level are very popular because of their clear, restrained effect. Generously and easily they eliminate the separation between shower and rest of the bathroom. Whether as a single partition wall or as a more complex corner situation, the easy access to the shower is especially appreciated here.

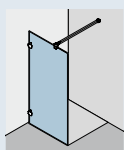

530W/P

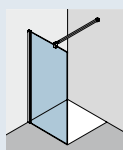

530W/P

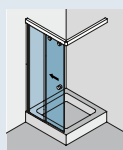

530(ü)DT

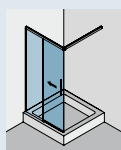

530(ü)DT

Hier sehen Sie nur eine kleine Auswahl möglicher Einbauvarianten. Weitere Einbausituationen können individuell realisiert werden.

Here are a few installation examples. Farther installation situations can be realised individually.

WINKEL BRACKET

Einzeltrennwand 530W Walk-In Dusche

- frei begehbar, türenlos
- Stabilität durch Wandbefestigung
- großzügiger Duscheinstieg
- barrierefrei
- beliebige Glasabmessungen

Single partition 530W Walk-in shower

- freely accessible, no doors
- wall fixing for stability
- spacious shower entry
- barrier-free
- variable glass dimensions



beschlagsabhängig
dependent on fittings



1 Winkel Glas/Wand 90°
bracket glass/wall 90°

2 Haltestange (eckig)
support bar (rectangular)

3 Haltestange (rund)
support bar (round)

PROFIL PROFILE

Einzeltrennwand 530P Walk-In Dusche

- frei begehbar, türenlos
- Stabilität durch Wandbefestigung
- großzügiger Duscheinstieg
- barrierefrei
- beliebige Glasabmessungen

Single partition 530P Walk-in shower

- freely accessible, no doors
- wall fixing for stability
- spacious shower entry
- barrier-free
- variable glass dimensions



1 Wandprofil
wall profile

2 Haltestange (eckig)
support bar (rectangular)

3 Haltestange (rund)
support bar (round)



SO 730

Schiebetürsystem 530(ü)DT Walk-In Dusche

- raumsparend
- Stabilität durch Querverstrebung **1**
- großzügiger Duscheinstieg
- bei Übergrößen mit Deckenstütze (s. S. 36)

Sliding door system 530(ü)DT Walk-In shower

- space saving
- cross connection for stability **1**
- spacious shower entry
- for oversizes with ceiling support (s. p. 36)



1 Querverstrebung
cross connection

2 Schiebetürlaufwagen (außen)
sliding door unit (outside)

3 Schiebetürgriff
sliding door knob

SF 740 PREMIUM

Schiebetürsystem 530(ü)DT Walk-In Dusche

- raumsparend
- Stabilität durch Deckenbefestigung **1**
- großzügiger Duscheinstieg
- Wand-Deckenmontage
- beliebige Glasabmessungen

Sliding door system 530(ü)DT Walk-In shower

- space saving
- ceiling fixing for stability **1**
- spacious shower entry
- wall and ceiling fixing
- variable glass dimensions



1 Deckenmontage
Ceiling fixing

2 vormontierte Funktionselemente
pre-fitted functional elements

3 einfache Reinigung
easy cleaning



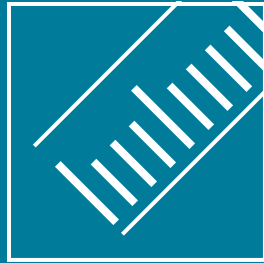

SONDERLÖSUNGEN SPECIAL SOLUTIONS

Besondere Raumsituationen erfordern besondere Duschlösungen. Ob im privaten oder öffentlichen Einsatzbereich gral überzeugt auch hier mit einer großen Variantenvielfalt. Sprechen Sie uns an. Folgend ein paar Anwendungsbeispiele.

Extraordinary room situations require specialized shower solutions. Regardless if in a private or public solution, gral provide a convincing variation to suite all needs. Feel free to contact us. Following some application situations.

BF 134

Pendeltürsystem – Eckdusche an Wanne

- nach innen/außen öffnend
- Türbeschläge mit Federmechanismus
- selbstschließend ab 20°
- Seitenteil innen bündig mit Badewannenaußenkante **1**

Double-action door system – Corner shower on bathtub

- inward/outward opening
- door fittings with spring mechanism
- self-closing from 20°
- side panel inside flush with outer edge of bathtub **1**



1 Band Glas/Wand
hinge glass/wall

2 Band Glas/Glas 90°
hinge glass/glass 90

3 Winkel Glas/Wand 90°
bracket glass/wall 90°

BF 134

Pendeltürsystem – T-Beschläge für Duschtüren

- nach innen/außen öffnend
- T-Band Glas/Glas 90°/180° mit Federmechanismus
- Beschläge für Türflügel und Trennwände
- selbstschließend ab 20°

Double-action door system – T-Fittings for shower doors

- inward/outward opening
- T-Hinge glass/glass 90°/180° with spring mechanism
- fittings for door panels and partition walls
- self-closing from 20°



1 T-Band Glas/Glas 90°/180°
T-Hinge glass/glass 90°/180°

2 Winkel Glas/Wand 90°
bracket glass/wall 90°

3 Sonderlösung geöffnet
special solution, opened

BO 410/415

Anschlagtürsystem – Eckdusche auf Mauerwerk

- nach außen öffnend
- für 135° Anwendungen
- Band Glas/Wand mit Anschraubplatte außen **2**

Single-action door system – Corner shower on wall

- outward opening
- for 135° applications
- hinge glass/wall with reversible external fixing plate **2**



1 Band Glas/Glas 135°
hinge glass/glass 135°

2 Sonderl. Band Glas/Wand 135°
special hinge glass/wall 135°

3 Vierkantprofil + Magnetsichtung
square profile + magnetic seal

SO 730

Schiebetürsystem – Walk-In Dusche

- großzügiger Duscheinstieg
- Stabilität durch Deckenstütze + Querverstrebung **1**
- bei Übergrößen (> 1.000 mm) immer mit Deckenstütze **1**

Sliding door system – Walk-In shower

- spacious shower entry
- ceiling support and cross connection for stability **1**
- for oversize (> 1.000 mm) always with ceiling support **1**



1



2



3

1 Deckenstütze + Querverstrebung
ceiling support + cross connection

2 Schiebetürlaufwagen (außen)
sliding door unit (outside)

3 Schiebetürgriff
sliding door knob

SO 730

Schiebetürsystem – Eckdusche an Mauervorsprung

- raumsparend
- optimierter Duscheinstieg, Schiebetür verläuft hinter Wandvorsprung **1**
- Sonderbearbeitung des Laufrahmenprofils **2**

Sliding door system – Corner shower on wall

- space saving
- optimized shower entry, sliding door runs behind wall projection **1**
- slide frame profile with special preparation **2**

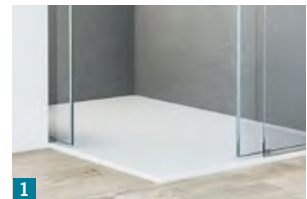

1



2



3

1 optimierter Duscheinstieg
optimised shower entry

2 Laufrahmenprofil (innen)
slide frame profile (inside)

3 Schiebetürlaufwagen (außen)
sliding door unit (outside)

SO 730

Schiebetürsystem – Dusch-/WC-Lösung

- raumsparend
- T-Sonderlösung
- einflügelige Schiebetür
- wahlweise Dusch- oder WC-Bereich geschlossen
- für Privat- und Objektbäder

Sliding door system Shower-/WC-Solution

- space saving
- T-special solution
- single sliding door
- shower or WC area optionally closed
- for privat and project bathrooms



1



2



3

1 WC-Bereich offen
WC area open

2 Dusch-Bereich offen
shower area open

3 Schiebetürlaufwagen (außen)
sliding door unit (outside)

SF 740 PREMIUM

Schiebetürsystem – Dusch-/WC-Lösung

- raumsparend
- Eck-Sonderlösung
- Profil-Mittelpfosten für Kabinenverbindung **2**
- für Privat- und Objektbäder

Sliding door system Shower-/WC-Solution

- space saving
- corner-special solution
- profile middle post for cubicle connection **2**
- for privat and project bathrooms



1



2



3

1 blickdicht (RAL 9005)
opaque (RAL 9005)

2 Profil-Mittelpfosten
profile middle post

3 großzügiger Duscheinstieg
spacious shower entries

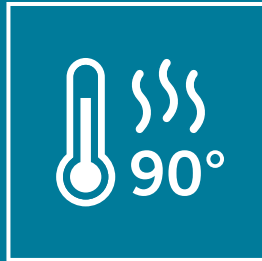

SAUNALÖSUNGEN SAUNA SOLUTIONS

Mit BF 112/BF 112 XL lassen sich klassische Saunakabinen bis hin zu größeren Saunalandschaften realisieren. Mit transparenten Glaselementen wird jeder Spa hell, einladend und zur Wohlfühloase.

With the BF 112/BF 112 XL, classic sauna cabins up to larger sauna landscapes can be realized. With transparent glass elements every spa becomes bright, inviting and feel-good oasis.

BO/BH/BF 112 BF 112 XL

Pendeltürsystem

- nach innen/außen öffnend
- Türbeschläge mit Federmechanismus
- einstellbare Nullstellung
- selbstschließend ab 20°
- geeignet bis 90° (Heißluft)
- Verschraubungen verdeckt

Double-action door system

- inward/outward opening
- door fittings with spring mechanism
- adjustable zero positioning
- self-closing from 20°
- suitable up to 90 degrees (hot air)
- concealed screw connections



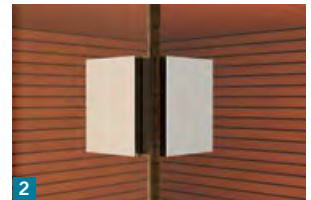

- 1 Band Glas/Wand
hinge glass/wall
- 2 Winkel Glas/Glas 90°
Bracket glass/glass 90°
- 3 Band Glas/Glas 180°
hinge glass/glass 180°



DESIGNVERBUND 112 DESIGN SERIES 112



Schwarz ist das neue Chrom. Mit matt schwarzen Oberflächen sorgen Sie für außergewöhnliche Kontraste und optische Highlights.

Black is the new chrome. With matt black surfaces, you create extraordinary contrasts and visual highlights.

Die Farbe Schwarz matt hat sich in den letzten Jahren als trendige neue Oberfläche im Badezimmer entwickelt. Mit unseren Beschlägen können Sie nun auch die Duschtrennung im einheitlichen Stil gestalten.

The colour matt black has emerged as a trendy new finish in the bathroom in recent years. With our fittings, you can now also design the shower enclosure in a uniform style.

Wir haben für Sie unsere beliebten Beschläge aus dem Designverbund 112 sowie passende Türgriffe und Haltestangen in der Farbe RAL 9005 matt (Schwarz matt) als Standardoberfläche 304 ans Lager gelegt, um die Lieferzeiten zu verkürzen.

We have stocked our popular 112 design composite fittings and matching door handles and support bars in RAL 9005 matt (black matt) as standard finish 304 to shorten delivery times.



BF 112



BH 112 Typ(e) 200W

Folgende Einzelartikel sind mit dem Farbcode 304 für RAL 9005 schwarz matt lagernd verfügbar und gelten in Schwarz nicht mehr als Sonderfarbe.

The following individual items are available from stock with colour code 304 for RAL 9005 black matt. For these selected articles, black is no longer valid as a special colour.



BF 112 XL

SONDEROBERFLÄCHEN SPECIAL SURFACES



Mit einer außergewöhnlichen Vielfalt an Oberflächen-Varianten setzt gral neue Trends im Badezimmer.

Offering an exceptionally broad range of surface finishes, gral sets new trends in bathroom styling.

Ob matt oder glänzend, poliert oder unpoliert, stylisch oder klassisch: Wählen Sie Struktur und Farbwirkung ganz nach Ihrem persönlichen Geschmack und Einrichtungsstil.

Matt, brilliant shine, polished, unpolished, modern or classic: the choice is yours – simply match the texture and color of our fixtures and fittings to your personal tastes and interior design requirements.

➔ Weitere Informationen zur »Colour Edition« auf www.gral-systeme.de.

Further information regarding »Colour Edition« on www.gral-systeme.de.

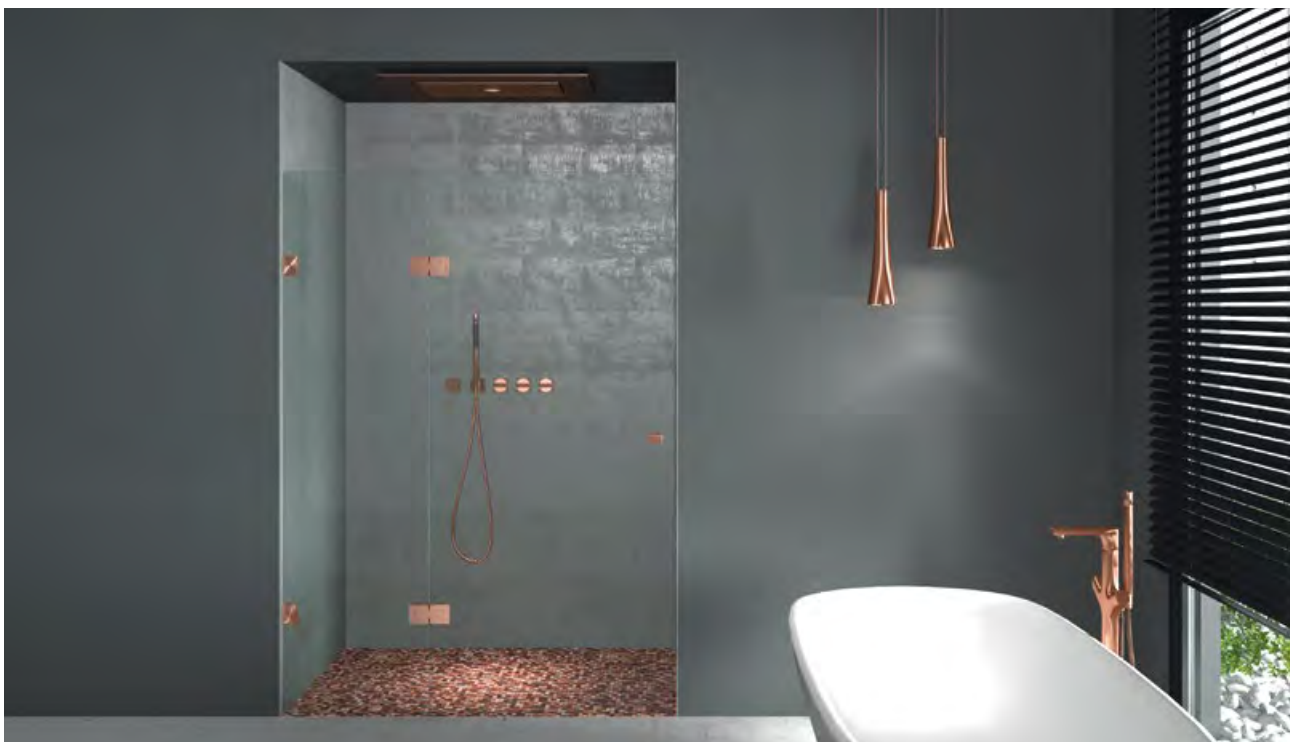

BF 112, Rosegold
BF 112, rose gold



 BF 112, Smoke Chrom
BF 112, smoke chrome



 SF 740, Schwarz matt,
RAL 9005 pulverbeschichtet
SF 740, black matt,
RAL 9005 powder coated



 SO 730, Grey line, pulverbeschichtet
SO 730, Grey line, powder coated

Sonderoberflächen am Beispiel BO 112 | Special surfaces – exemplified by the BO 112 range



1
Smoke Chrom
smoke chromed



2
Braun C34
dark bronze



3
Schwarz (9005) matt
black matt



4
Weiß (9016) matt
white matt



5
Kieselgrau (7032)
pebble grey



6
Elfenbein (1014)
ivory



7
Umbrä Grau (7022)
umbra grey



8
Perlgold (1036)
pearl gold

Weitere Oberflächen, wie z. B.
vergoldet 24 Karat, Nickel matt/
glänzend nur auf Anfrage

Further surfaces such as gold
plated 24 carat, nickel matt/glossy
only on request

ZUBEHÖR & DETAILS ACCESSORIES & DETAILS

- Türgriffe und -Knöpfe
- Haltestangen
- Handtuchhalter
- Dichtprofile | Spritzschutz
- Verbauung ohne Dichtungsprofil
- Aluminiumprofile
- Door handles and knobs
- Support bars
- Towel Bars
- Sealing profiles | Splashguards
- Construction without sealing profiles
- Aluminium profiles

Für nahezu jede Duschsituation die richtigen Dicht-/Schwallschutzprofile, Magnetdichtungen und Wasserabweiser, sowie das umfangreiche Aluminiumprofilprogramm. Dazu passendes Zubehör wie Griffe, Handtuchhalter, Haltestangen, Glasablagerungen im runden oder quadratischen Design.

The range that offers the right sealing/anti-flooding profiles, magnetic gaskets and water deflectors together with a comprehensive range of aluminum extrusions. A comprehensive range of accessories like handles, towel holders, support bars, glass shelf in rectangular or square design.

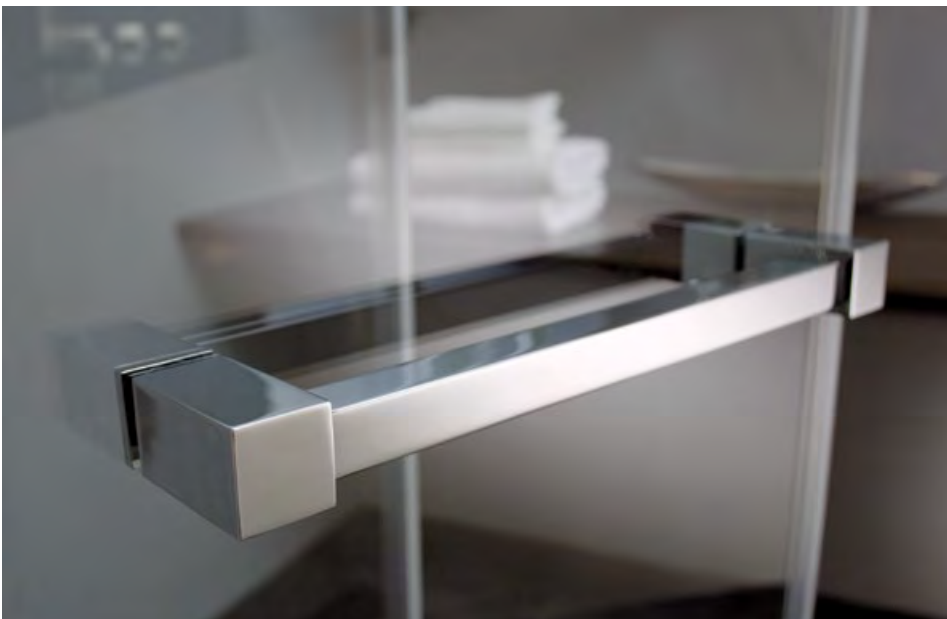

Z-Laschen für Badewannen-Seitenteilfixierung

Z-Connector for bathtub side element fixation



Dreiecksglas | Triangle glass



TÜRGRIFFE UND -KNÖPFE DOOR HANDLES AND KNOBS

Mit einer großen Palette an Türgriffen und -knöpfen bietet Gral Gestaltungsfreiheit. Wie Schmuckstücke bringen die Griffvarianten das individuelle Einrichtungskonzept im Bad auf den Punkt und sorgen auf

ergonomische Weise für einen sicheren Ein- und Ausstieg.

Tipp: Horizontal montierte Stangengriffe bieten als Handtuchstange einen praktischen Zweitnutzen.

gral's extensive portfolio of rails, handles and knobs offers more scope for creative design. Like jewels, the various fittings add flair to any individual bathroom concept while also ensuring

the ergonomics required for safe cubicle entry and exit.

Tip: A horizontal pull bar can always double up as a handy towel rail.





Türknohf, rund, beidseitig
Door knob, round, both sides



Türknohf, rund (Diabolo), beidseitig
Door knob, round (diabolo), both sides



Türknohf, Trapez, beidseitig
Door knob, trapez, both sides



Schiebetürgriff, rund, beidseitig
Sliding door, knob round, both sides

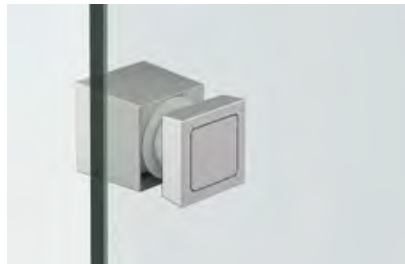

Schiebetürknohf, Trapez, beidseitig (außen)
Sliding door knob, trapez both sides (outside)



Schiebetürgriffmuschel (außen)
Sliding door pull grip (outside)



Falrtürknohf, Trapez, Gummianschlag beidseitig
Folding door knob, trapez, buffer both sides



Türgriff, eckig, BF 112, beidseitig
Door handle, rectangular, BF 112, both sides



Türgriff, soft edge, beidseitig
Door handle, soft edge, both sides



Griffstange, eckig/rund, beidseitig
Handle bar, rectangular/ round, both sides



Griffstange, eckig, einseitig
Handle bar, rectangular, one side



Schiebetürgriffleiste, eckig, SF 740 (außen)
Sliding door handle, rectangular, SF 740 (outside)

HALTESTANGEN SUPPORT BARS

Sicherer Halt für elegante Glasduschen: Ob rund oder eckig im Design, ob für Decken- oder Wandmontage oder speziell für Dach-schrägen – unsere Stabilisationssysteme sind auf jede Raumsituation verwendbar. Das garantiert gut gesicherten, unbeschwerten Duschgenuss.

Secure mountings for elegant glass shower cubicles: Whether round or angular in design, whether for ceiling installation or wall fixing, and especially for sloping roofs – our systems offer excellence in design and stability in any room situation. And that means super-safe, care-free showering enjoyment.



Haltestange, eckig, Glas/Glas | Support bar, rectangular, glass/glass



Haltestange, rund
Support bar, round



Haltestange, eckig
Support bar, rectangular



Haltestange, eckig, Reling | Support bar, rectangular, reiling

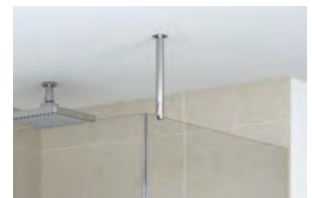

Deckenanschluss, rund
Ceiling installation, round



Haltestange, rund, Glas/Wand, einstellbar

Support bar, round, glass/wall, adjustable



Haltestange, rund, Glas/Wand, einstellbar mit T-Verbinder

Support bar, round, glass/wall, adjustable with T-connection



Haltestange, eckig, Glas/Wand, einstellbar

Support bar, rectangular, glass/wall, adjustable



Haltestange, eckig, einstellbar, auch für Dachschrägen geeignet

Support bar, rectangular, glass/wall, adjustable, suitable for diagonal roof



Haltestangen, rund oder eckig, für Fünfeck-Duschen

Support bar, round or rectangular for pentangular showers

Kurze Haltestange rund, Glas/Wand, einstellbar

Short support bar, round, glass/wall, adjustable

HANDTUCHHALTER TOWEL BARS

Formvollendet präsentiert sich Funktionales und macht im Alltag Freude: Die Handtuchstangen im runden oder eckigen Design, lassen sich innen flächenbündig montieren. Der Pluspunkt ist somit eine einfache Reinigung. So schön kann Praktisches sein.

With *gral*, the functional takes on fabulous form, making each morning shower a delight. The towel rails of round or rectangular design offer all the intricacy of flush button mounting on the inside, with the added benefit of easy cleanability. Practical and beautiful at the same time.





Handtuchstange eckig
wahlweise doppelseitig oder
innen flächenbündig

Towel rail rectangular
optionally back-to-back or
countersunk



Handtuchstange rund
wahlweise doppelseitig oder
innen flächenbündig

Towel rail round
optionally back-to-back or
countersunk

DICHTPROFILE | SPRITZSCHUTZ SEALING PROFILES | SPLASHGUARDS

Glasduschen sind keine Aquarien. Passgenaue eingesetzte Dicht- und Spritzschutzprofile gewährleisten eine optimale Abdichtung. Magnetdichtungen an den Glasstürkanten sorgen für leises und millimetergenaues Schließen.

A Glass shower cubicle is not an aquarium. Exact-fitting gasket extrusions and spray-protection profiles ensure optimum water containment, while magnetic seals on the glass door edges ensure quiet closing with millimeter accuracy.



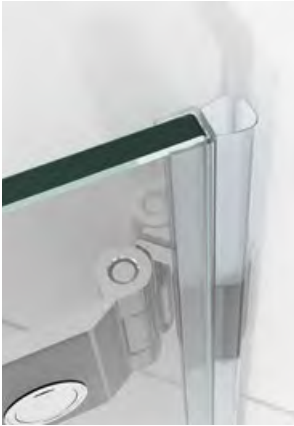

Schlauchdichtung
Soft nose seal



Vierkantprofil, durchgehende
Magnetdichtung | Square profile,
continuous magnetic seal



Magnetdichtung 180° für Pendel-
türen | Magnetic seal 180° for
double-action doors



Magnetdichtung 90°
Magnetic seal 90°



Magnetdichtung 90°, Aluminium
Magnetic seal 90°, aluminium



Anschlagdichtung 90°
Rebate seal 90°



Magnetdichtung 90° für Pendel-
türen | Magnetic seal 90° for
double-action doors



Wasserabweiser
Water disperser



Wasserabweiser mit Alu-Schwall-
schutzprofil | Water disperser with
aluminium splashguard profile



Wasserabweiser mit Acryl-Schwall-
schutzprofil | Water disperser with
acrylic splashguard profile



Wasserabweiser mit Acryl-Schwall-
schutzprofil | Water disperser with
acrylic splashguard profile

VERBAUUNG OHNE DICHTPROFILE CONSTRUCTION WITHOUT SEALING PROFILES

Klarheit auf ganzer Linie verspricht eine Verbauung ohne Dichtprofile, die bei bestimmten baulichen Voraussetzungen realisierbar ist. Mit der Beschlagserie

BF 112 lassen sich die Spaltmaße auf ein Minimum reduzieren. Die pure, höchästhetische Optik begeistert Designfreunde.

Assembly without additional sealing profiles – available subject to certain structural requirements – creates clean, clear design lines. With the BF 112, for example, gap

dimensions can be reduced to an absolute minimum, creating a pure, highly aesthetic appearance that will always please those with an eye for excellence.

Verbauung **ohne** Dichtprofile (wandseitig 3 mm Spaltmaß)
Construction **without** sealing profiles (wall side 3 mm clearance)

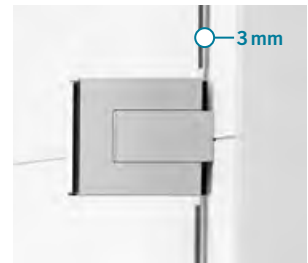

Verbauung **mit** Dichtprofil (wandseitig 11 mm Spaltmaß)
Construction **with** sealing profiles (wall side 11 mm clearance)





Bodenebene Verbauung mit Gefälle:
Durch die eingerückte Tür läuft das Spritzwasser vom Glas in die Dusche.

Floor-level installation with a slope: With the door inset, spray water from the glass flows back into the shower.



Abgesenkter Boden mit Gefälle:
Auch hier läuft das Spritzwasser vom Glas in den Duschbereich.

Sunken floor with slope: Here again, spray water from the glass flows back into the shower.



Einbausituation mit Duschtasse:
Durch die eingerückte Tür verbleibt das Wasser auch ohne Dichtprofil im Duschbereich.

Installation with shower tray: With the door inset, the water remains in the shower area even without a sealing profile.

ALUMINIUMPROFILE ALUMINIUM PROFILES

Sanft schimmerndes Aluminium beweist im Zusammenspiel mit Glas in der Badarchitektur Klasse. Mit dem umfangreichen Aluminiumprofilprogramm nimmt nahezu jede Idee rund um zeitgemäße Duschsysteme Gestalt an.

In combination with glass, softly shimmering aluminum exudes class in bathroom architecture. With an extensive range of aluminum extrusions, even the most ambitious design ideas for modern shower styling can be realized.





Schiebetür-Laufrahmenprofil (SO 730)
Slide frame profile for sliding doors (SO 730)



Schiebetür-Laufrahmenprofil (SO 730-Sonder)
Slide frame profile (SO 730 special)



Schiebetür-Laufrahmenprofil (SF 740)
Slide frame profile (SF 740)



Deckenmontage Schiebetürsystem (SF 740)
Ceiling fixing Sliding door system (SF 740)



Schiebetür-Laufrahmenprofil (SF 740)
Slide frame profile (SF 740)



Deckenmontage Schiebetürsystem (SF 740)
Ceiling fixing Sliding door system (SF 740)



Klemmprofil mit eckigem Abdeckprofil
Clamp profile with angular cover profile



Klemmprofil mit abgerundetem Abdeckprofil
Clamp profile with curved cover profile



U-Profil
U-profile

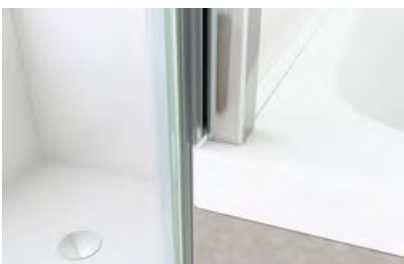

Aufsatzprofil und Magnetleistenträger
Attachment profile and magnetic support profile



Eckprofil 90° (für Glas/Glas Verbindungen)
Corner profile 90° (for glass/glass connections)

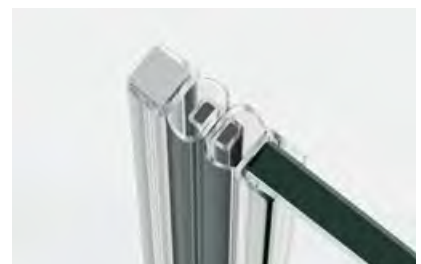

Vierkantprofil (Aufnahme für Kunststoffprofil)
Square profile (holder for acrylic profile)

PRODUKTZERTIFIZIERUNG
DIN EN 14428
PRODUCT CERTIFICATION
EN 14428

Alle gral Duschbeschlagserien (Basismaterial Messing) sind Qualitätsprodukte. Produktzertifizierungen unterstützen Sie bei der Bewerbung und Planung bis zur finalen Objektrealisation.

gral shower hinge series (basic material brass) are all of high quality. Product certifications will help you beginning of promotion and planning till to final object realisation.

gral Duschsysteme und Beschlagserien sind gemäß der europäischen DIN EN 14428 (CE-Kennzeichnung) auf Stabilität, Dauerhaftigkeit und Dichtigkeit erfolgreich getestet.

gral shower systems and hinge series are tested according to the European EN 14428 (CE marking) of Stability, durability and water-tightness.



Zu jedem Duschsystem steht eine Konformitätserklärung zur Verfügung. Die montagefertigen Bausätze für maßgefertigte Duschen entsprechen in der Komposition ihrer Elemente garantiert den getesteten Systemen.

A Declaration of Conformity is available for each shower system. The installation-ready assembly kits for tailor-made showers are guaranteed to conform to the tested systems in terms of make-up and technology.

→ Alle Konformitätserklärungen auf www.gral-systeme.de

All Certificates of Conformity on www.gral-systeme.de

DIN EN 14428

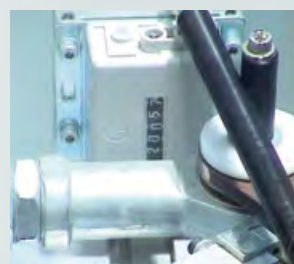

AUSSTELLUNGSMODULE DEMONSTRATION MODULES

- Musterkoffer
- Tischfunktionsmuster
- Mobiler Präsenter
- Sample case
- Desktop Demo Units
- Mobile Presentation Unit

Ob beim Kunden vor Ort, bei Präsentationen oder in Ihrer Ausstellung – die Produkte selbst sind Ihre besten Argumente im Beratungs- und Verkaufsgespräch. Nutzen Sie dazu unsere verschiedenen Ausstellungsmodule.

Whether at the customer's site, at presentations or at your own exhibition – the products themselves are your best arguments in consultations and sales negotiations. So make the most of our range of display modules!

Musterkoffer | Sample case

Hochwertiger Musterkoffer aus Aluminium zur Präsentation einzelner Duscheschlagskomponenten.

High-quality sample case off aluminium for presentation of single shower hinge components.



Art.-Nr. | Art. No. 8.77.995.999.99
Preis netto | Price net 500,00 €
(bei Standardoberflächen
with standard surfaces)



Inhalt frei definierbar

Definieren Sie maximal 10 Produktkomponenten in gewünschter Standardoberfläche aus dem gesamten Produktportfolio (mehr als 10 Stück und Sonderoberflächen auf Anfrage).

Content free definable

Define maximum 10 product components in desired standard surface from the entire product portfolio (more than 10 pieces and special surfaces on request).

Tischfunktionsmuster I Desktop Demo Units

Ideal für Produktpräsentationen, technische Schulungen, wo die Funktionen der Duschbeschläge im eingebauten Zustand dargestellt werden. Komplet montiert, einfaches Handling. Perfekt als zusätzliches Ausstellungsmodul im Showroom.

For product presentations and technical training courses where the functions of the shower fittings need to be demonstrated in their installed condition. Completely assembled, easy to use. Ideal as an additional exhibition module in the showroom.



Art.-Nr. und Serien siehe gral Preisliste I Art. No., and Series see gral price list – Preis netto I Price net 170,00 €

Mobiler Präsenter I Mobile Presentation Unit

Das bewegliche Ausstellungsmodul zur Präsentation individueller Ganzglasduschen. Verfügbar in Basisfarbe Schwarz/Weiß. Maximale Darstellung von vier verschiedenen Band-System-/Serien. Bestückung nach Wunsch. Wir beraten Sie gerne bei der Produkt-Zusammenstellung.

The wheeled demonstration module for presentation of individual glass shower systems. Available in basic colour black/white. Maximum representation of four different hinge-system-/series. Assembly on request. We will be glad to assist you in your product compilation.



Geeignet für jede gral Duschbeschlagsreihe
Suitable for all gral shower fitting series

Abmessung (B×T×H)
Dimension (W×D×H)
1250 × 1250 × 2252 mm

Preis netto I Price net
inkl. Glas I incl glass 1950,00 €
optional ohne Glas I
optionally without glass 1780,00 €

Duschsystem	BO 112	BO 410	BO 415	BH112	BH200	BH205	BH250	BH255	BO 381	Paro	Opalea
Basismaterial	Messing	Messing	Messing	Messing	Messing	Messing	Messing	Messing	Messing	Messing	Messing
DIN EN 14428	■	■	■	■	■	■	■	■	■	■	■
Glasart	ESG	ESG	ESG	ESG	ESG	ESG	ESG	ESG	ESG	ESG	ESG
max. Tragfähigkeit (2 Bänder)	40 kg	40 kg	40 kg	40 kg	40 kg	36 kg	36 kg	36 kg	36 kg	36 kg	45 kg
max. Türbreite bei Türhöhe von 2.000 mm (bei vorgeschriebener Glasstärke)	1.000 mm (8 mm)	1.000 mm (8 mm)	1.000 mm (8 mm)	1.000 mm (8 mm)	1.000 mm (6/8 mm)	1.000 mm (6 mm) 900 mm (8 mm)	1.000 mm (6 mm) 900 mm (8 mm)	1.000 mm (6 mm) 900 mm (8 mm)	1.000 mm (6 mm) 900 mm (8 mm)	900 mm (8 mm)	1.000 mm (8 mm)
für Saunabereich geeignet (bis 90°C)											■
durchgehende Dichtung (im Bandbereich)	■	■	■	■	■	■	■	■			
optimiert zum Einbau ohne Dichtungen											■
einstellbare Nullstellung											■
selbstschließend				■	■	■	■	■			■
Soft-Einzug											
Soft-Stop											
verdeckte Wandbefestigung	■	■	■	■	■	■	■	■	■	■	■
flächenbündige Glasbefestigung			■			■	■		■	■	
Wandbefestigung mit Langlöchern	■	■	■	■	■	■	Winkel ■ Glas/Wand	Winkel ■ Glas/Wand	■	■	■
mit gebogenen Türflügeln						■	■				

BF 112	BF112 XL	BF 134	BH2401 nursolange der Vorrat reicht	Pontos	BF112	BF112 XL*	Pontos	BF 134	SO 730	SF 740 PREMIUM
Messing	Messing	Messing	Messing	Zinkdruckguss/ Aluminium	Messing	Messing	Messing/ Aluminium	Messing	Messing/ Aluminium	Messing/ Aluminium
■	■	■	■	■	■	■	■	■	■	■
ESG	ESG	ESG	ESG	ESG	ESG	ESG	ESG	ESG	ESG	ESG
45 kg	60 kg	40 kg	40 kg	28 kg	45 kg	45 – 60 kg*	32 kg	40 kg	40 kg	50 kg
1.000 mm (8 mm)	1.200 mm (10 mm) 1.000 mm (12 mm)	1.000 mm (8 mm) 800 mm (10 mm)	1.000 mm (8 mm)	1.000 mm (6 mm)	1.000 mm (8 mm)	1.200 mm* (8 mm)	1.200 mm (6 mm)	1.000 mm (8 mm)	900 mm (8 mm)	1.250 mm (8 mm) 1.000 mm (10 mm)
■	■									
				■	Band ■ Glas/Glas	Band ■ Glas/Glas	Band ■ Glas/Glas	Band ■ Glas/Glas	■	■
■	■				Band ■ Glas/Wand	Band ■ Glas/Wand				
■	■			bei ■ Glas/Glas	Band ■ Glas/Wand	Band ■ Glas/Wand				
■	■	■	■	■						■
										■
										■
■	■	■	■	■	■	■	■	■		
			■				■			
■	■	■	■	■	■	■	■	■		

* Nur bei Verwendung von Türbeschlägen BF 112 XL Glas/Wand mit zusätzlichen Zwischenlagen für 8 mm Glas.



ANSCHLAGTÜRSYSTEME SINGLE-ACTION DOOR SYSTEMS

BO 112

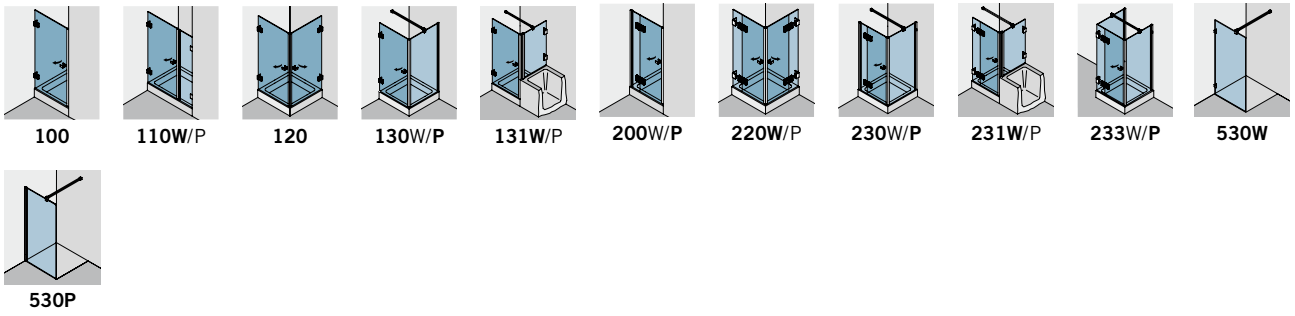

BO 410

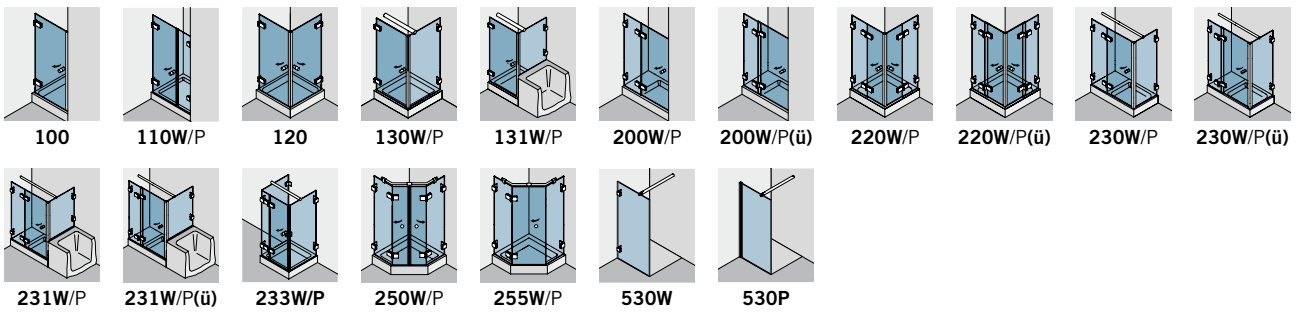

BO 415

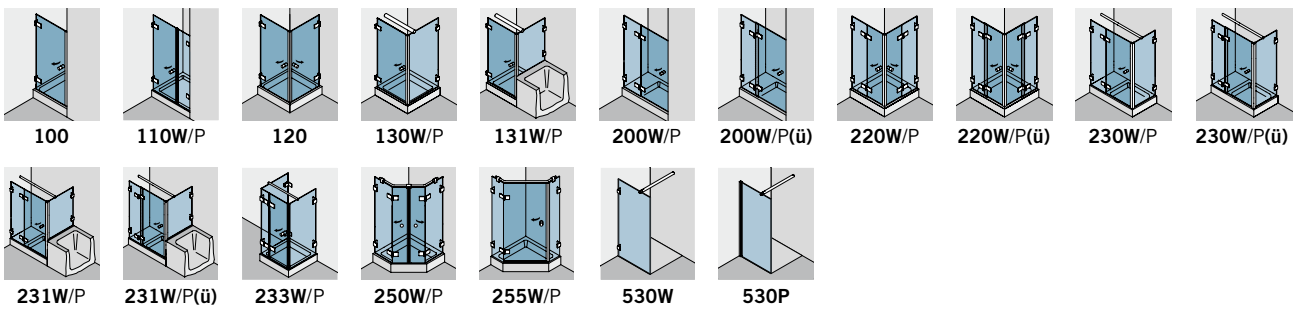

 **BH 112** mit Hebe-Senk-Funktion I with lift-lower-function

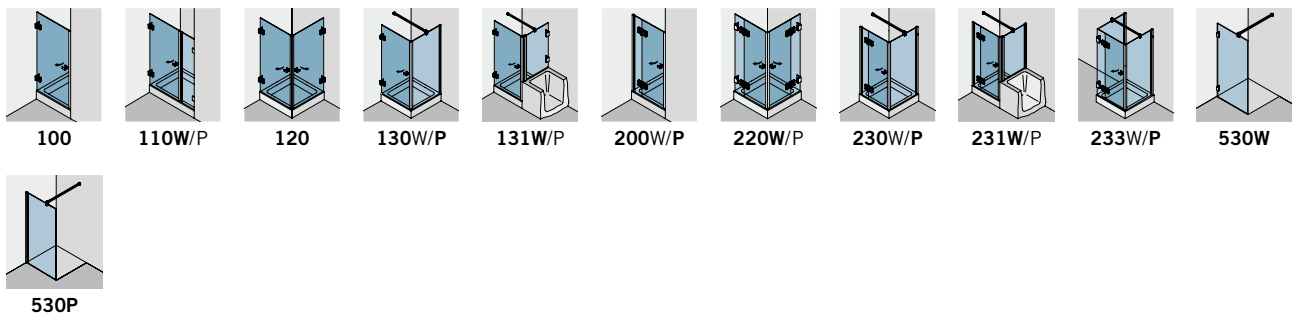

 **BH 200** mit Hebe-Senk-Funktion I with lift-lower-function

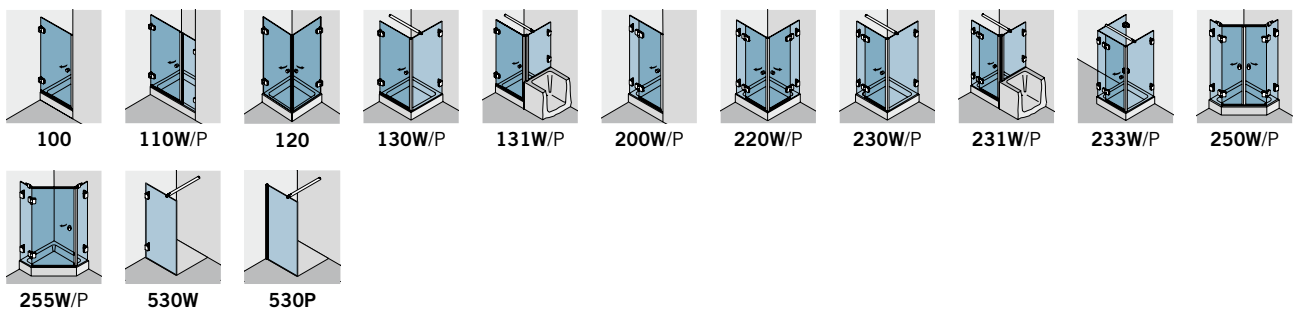

 **BH 205** mit Hebe-Senk-Funktion I with lift-lower-function

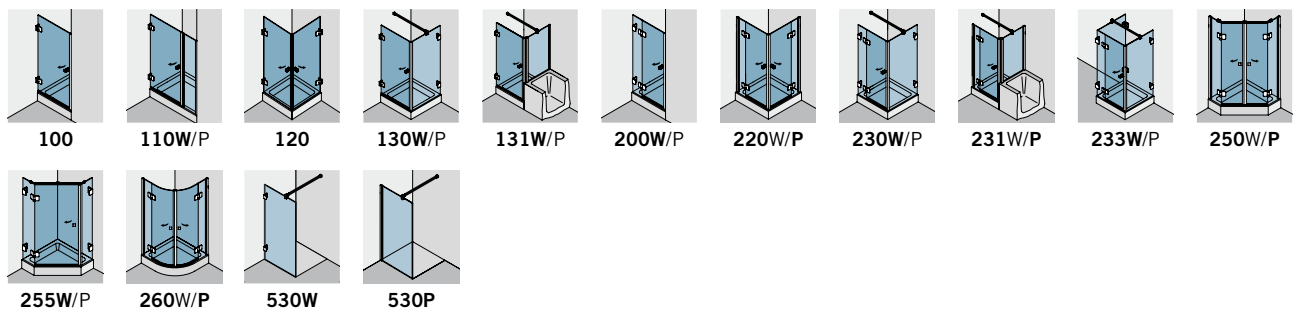

- W Fixteile werden mit Winkeln gehalten
fixed panels are held with brackets
- P Fixteile werden mit Profilen gehalten
fixed panels are held with profiles
- (ü) überlappende Glaselemente
overlapping glass elements



BH 250 mit Hebe-Senk-Funktion | with lift-lower-function

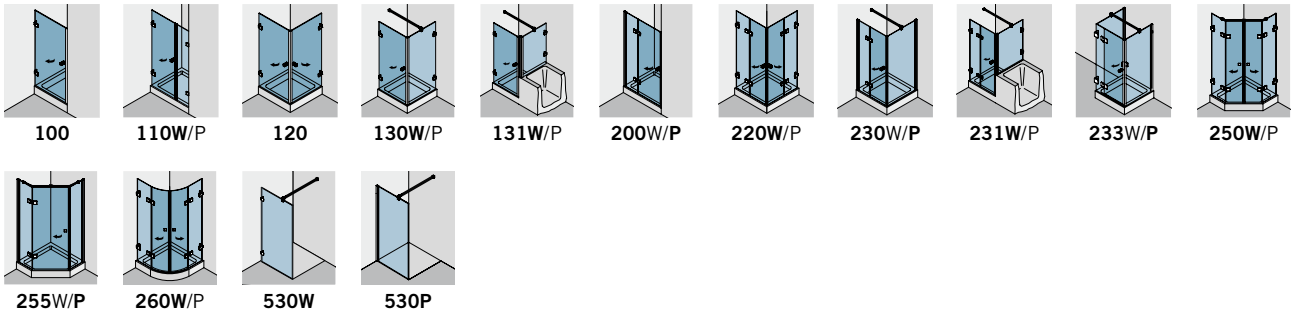

BH 255 mit Hebe-Senk-Funktion | with lift-lower-function

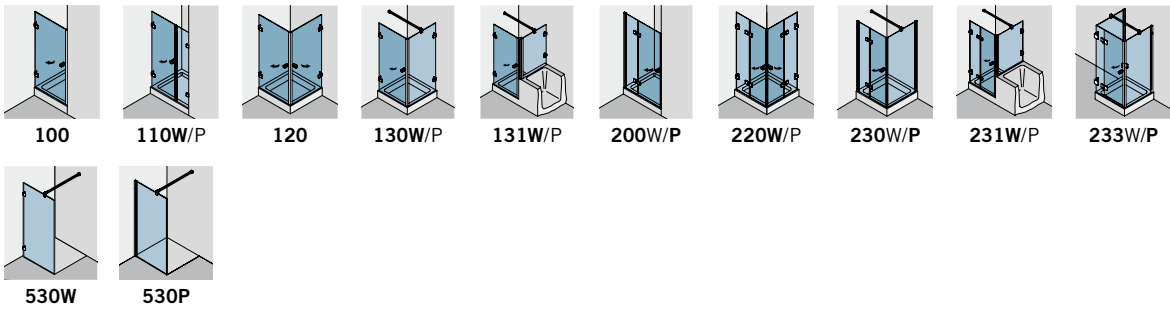

PENDELTÜRSYSTEME
DOUBLE-ACTION DOOR SYSTEMS



BF 112

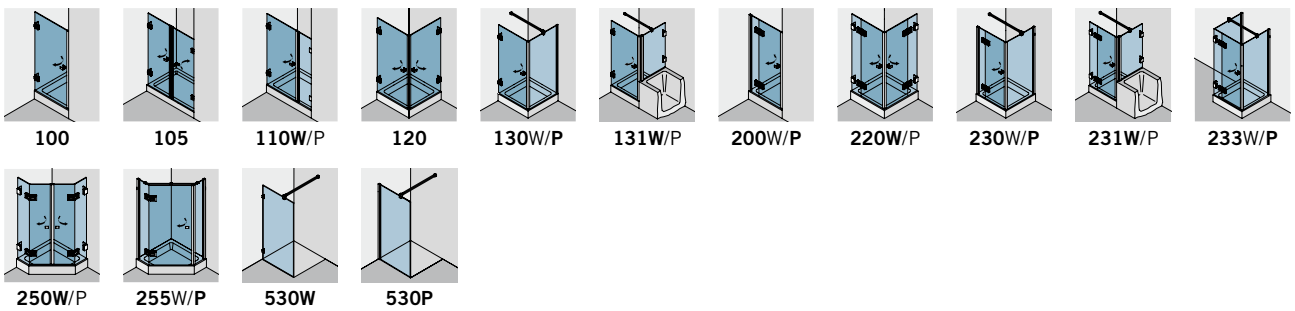

BF 112 XL

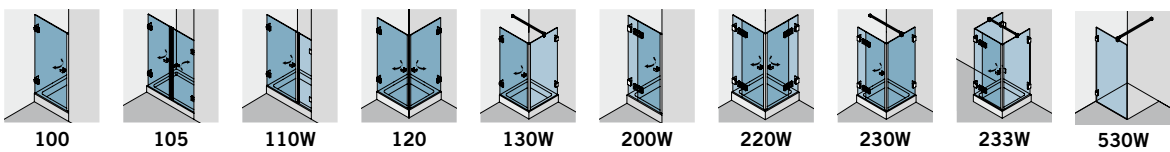

BF 134



Paro

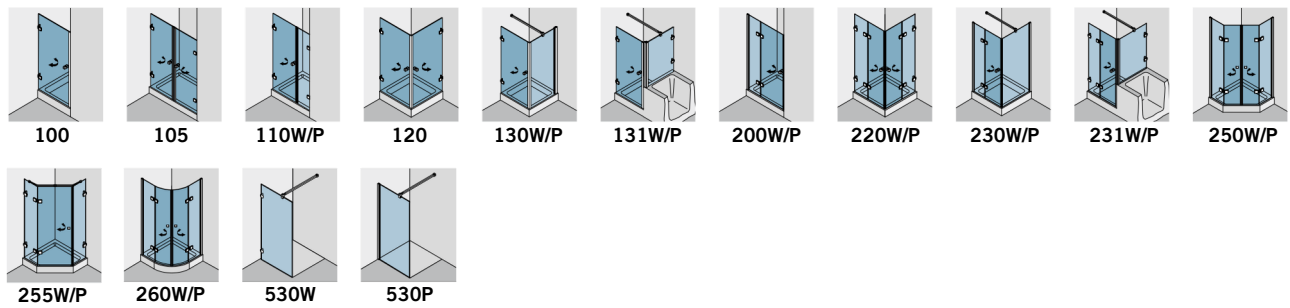

Opalea

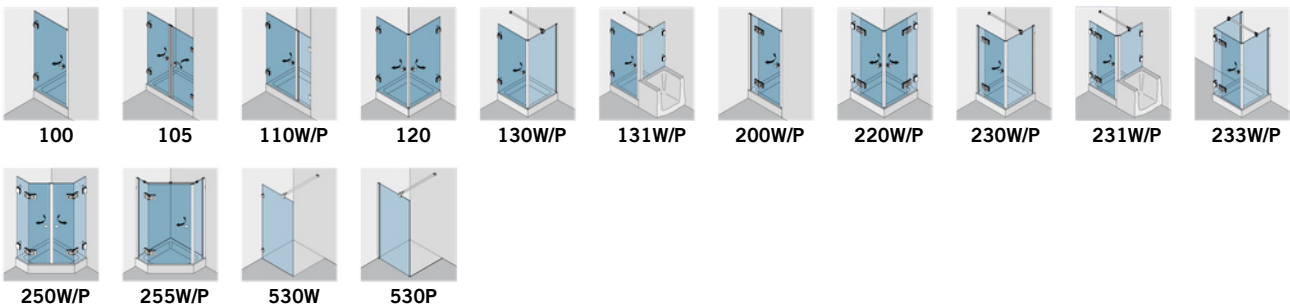

- W Fixteile werden mit Winkeln gehalten
fixed panels are held with brackets
- P Fixteile werden mit Profilen gehalten
fixed panels are held with profiles



FALTTÜRSYSTEME FOLDING DOOR SYSTEMS



BF 112

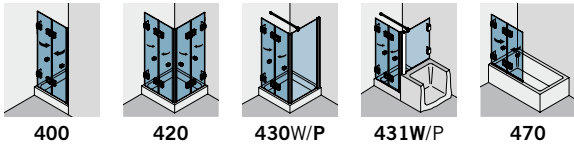

400

420

430W/P

431W/P

470



BF 112 XL

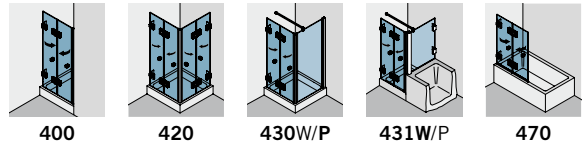

400

420

430W/P

431W/P

470



BF 134

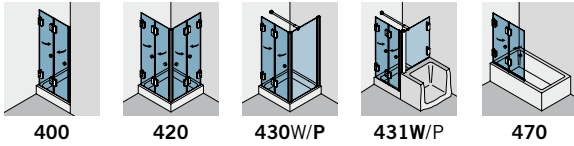

400

420

430W/P

431W/P

470



SCHIEBETÜRSYSTEME SLIDING DOOR SYSTEMS



SO 730

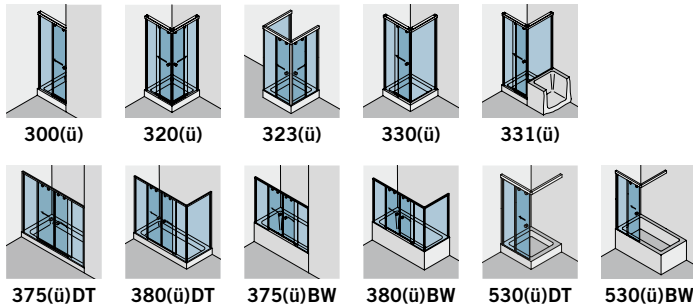

300(ü)

320(ü)

323(ü)

330(ü)

331(ü)

375(ü)DT

380(ü)DT

375(ü)BW

380(ü)BW

530(ü)DT

530(ü)BW



SF 740 PREMIUM mit Dämpfungs- und Einzugsfunktion | with damping and self-closing function

Wandmontage | Wall Fixing

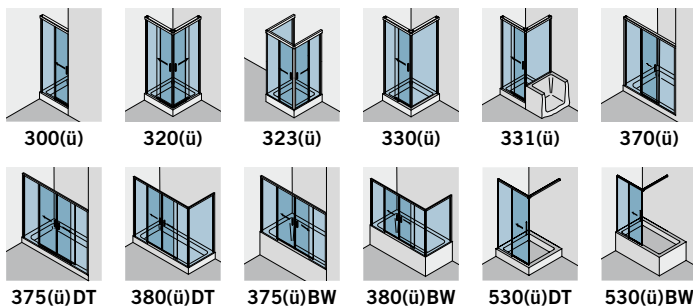

300(ü)

320(ü)

323(ü)

330(ü)

331(ü)

370(ü)

375(ü)DT

380(ü)DT

375(ü)BW

380(ü)BW

530(ü)DT

530(ü)BW

SF 740 PREMIUM mit Dämpfungs- und Einzugsfunktion | with damping and self-closing function

Deckenmontage | Ceiling fixing

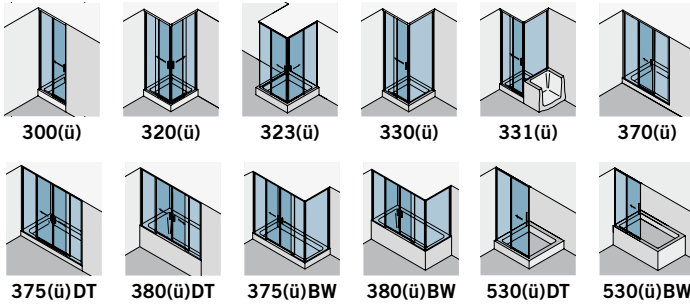

WALK-IN SYSTEME
WALK-IN SYSTEMS

Winkel | Bracket

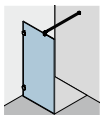

530W

Profil | Profile

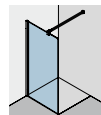

530P

SO 730

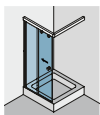

530(ü)DT

SF 740 Premium

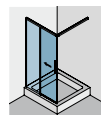

530(ü)DT

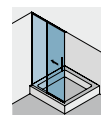

530(ü)DT

- W Fixteile werden mit Winkeln gehalten
fixed panels are held with brackets
- P Fixteile werden mit Profilen gehalten
fixed panels are held with profiles
- DT Duschtasse | Shower tray
- BW Badewanne | Bath tub
- (ü) überlappende Glaselemente
overlapping glass elements

E-SHOP E-SHOP

E-Shop

Mit dem gral E-Shop können Sie einfach und schnell Einzelkomponenten per Mausklick bestellen.

E-shop

With the gral e-shop all single components can be order easy and fast only with few clicks.

- Sie erreichen den E-Shop auf www.gral-systeme.de (Voraussetzung: User-Account)

You can access the e-shop on www.gral-systeme.de (Supposition: user account)



DUSCHENKONFIGURATOR SHOWER CONFIGURATOR

Konfigurator

Mit dem Duschkonfigurator planen Sie Ihre individuelle Dusche schnell und einfach auf Basis hinterlegter Typen.

Configurator

With the shower configurator, you can quickly and easily design your own custom shower based on pre-selected types.

- Sie erreichen den Konfigurator auf www.gral-systeme.de (Voraussetzung: User-Account)

You can access the configurator on www.gral-systeme.de (Supposition: user account)

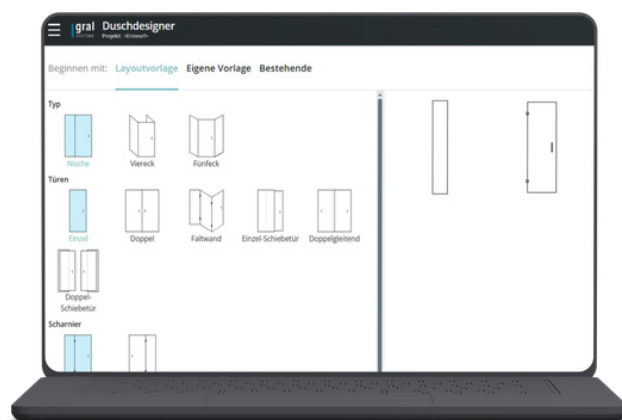

PROSPEKTÜBERSICHT BROCHURE OVERVIEW



BF 112



BF 112 XL

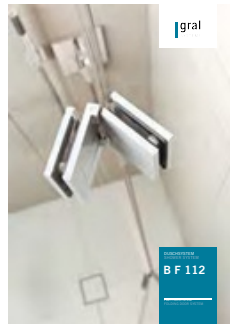

BF 112

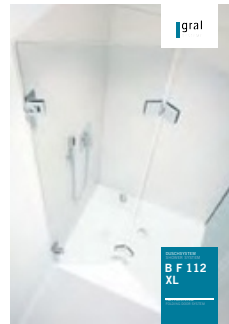

BF 112 XL



BF 134

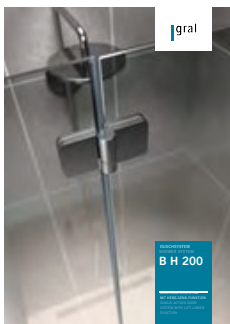

BH 200

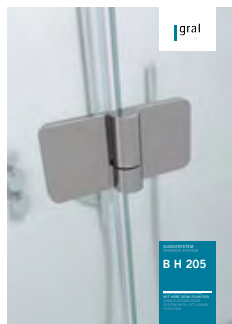

BH 205

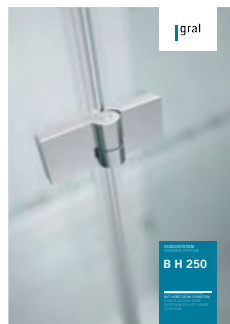

BH 250

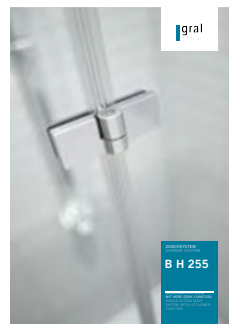

BH 255

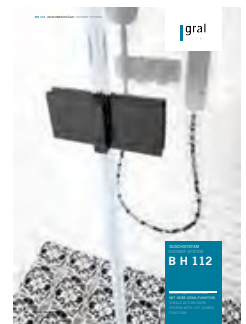

BH 112

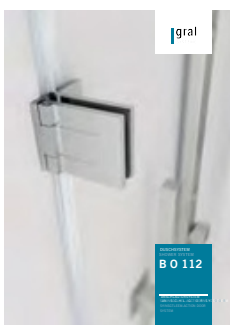

BO 112



Paro



Opalea

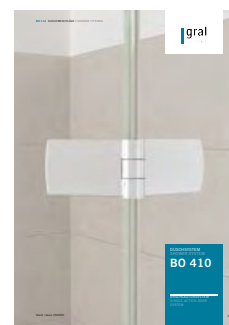

BO 410



BO 415

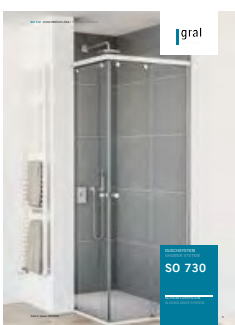

SO 730

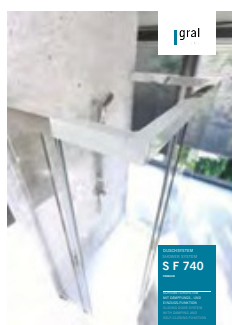

SF 740

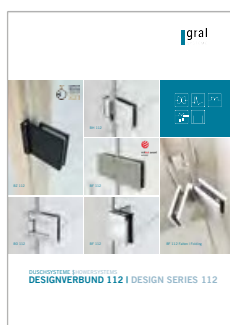

**Designverbund 112
Design Series 112**

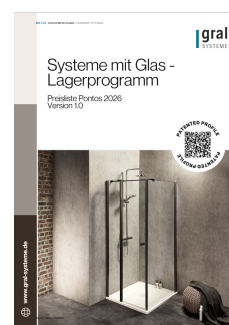

Pontos

□ Weitere Informationen
auf www.gral-systeme.de
Further information
on www.gral-systeme.de



Gral Systeme GmbH

Ludwig-Erhard-Straße 7
33397 Rietberg
GERMANY

Phone +49 (0) 5244 9076-0
Fax +49 (0) 5244 9076-219

www.gral-systeme.de